

# ENGINE

# 4G6 SERIES

## CONTENTS

GENERAL INFORMATION .....	11A-0-3
1. SPECIFICATIONS .....	11A-1-1
SERVICE SPECIFICATIONS .....	11A-1-1
TORQUE SPECIFICATIONS .....	11A-1-4
NEW TIGHTENING METHOD - BY USE OF BOLTS TO BE TIGHTENED IN PLASTIC AREA ..	11A-1-9
SEALANTS .....	11A-1-9
FORM-IN-PLACE GASKET .....	11A-1-10
2. SPECIAL TOOLS .....	11A-2-1
3. ALTERNATOR AND IGNITION SYSTEM .....	11A-3-1
3a. INTAKE MANIFOLD (GDI) .....	11A-3a-1
4. TIMING BELT .....	11A-4-1
4a. EXHAUST MANIFOLD (GDI) .....	11A-4a-1
5. FUEL AND EMISSION CONTROL PARTS .....	11A-5-1
5a. FUEL PARTS (GDI) .....	11A-5a-1
6. WATER PUMP AND INTAKE MANIFOLD .....	11A-6-1
6a. WATER PUMP AND WATER HOSE (GDI) .....	11A-6a-1
7. EXHAUST MANIFOLD .....	11A-7-1
8. ROCKER ARMS AND CAMSHAFT .....	11A-8-1
8a. ROCKER ARMS AND CAMSHAFTS (GDI) .....	11A-8a-1
9. CYLINDER HEAD AND VALVES .....	11A-9-1
10. FRONT CASE, COUNTERBALANCE SHAFTS AND OIL PAN	11A-10-1
11. PISTON AND CONNECTING ROD .....	11A-11-1
12. CRANKSHAFT, FLYWHEEL AND DRIVE PLATE .....	11A-12-1

NOTES

**GENERAL INFORMATION****SOHC-4G63**

Descriptions			Specifications
Type			In-line OHV, SOHC
Number of cylinders			4
Combustion chamber			Pentroof type
Total displacement dm <sup>3</sup>			1,997
Cylinder bore mm			85.0
Piston stroke mm			88.0
Compression ratio			10
Valve timing	Intake valve	Opens (BTDC)	18°
		Closes (ABDC)	58°
	Exhaust valve	Opens (BBDC)	58°
		Closes (ATDC)	18°
Lubrication system			Pressure feed, full-flow filtration
Oil pump type			Involute gear type

**SOHC-4G64**

Descriptions			Specifications
Type			In-line OHV, SOHC
Number of cylinders			4
Combustion chamber			Pentroof type
Total displacement dm <sup>3</sup>			2,351
Cylinder bore mm			86.5
Piston stroke mm			100.0
Compression ratio			10
Valve timing	Intake valve	Opens (BTDC)	16°
		Closes (ABDC)	53°
	Exhaust valve	Opens (BBDC)	50°
		Closes (ATDC)	16°
Lubrication system			Pressure feed, full-flow filtration
Oil pump type			Involute gear type

**GDI™**

Descriptions		Specifications	
Type		In-line OHV, SOHC	
Number of cylinders		4	
Combustion chamber		Pentroof + curved top piston type	
Total displacement dm <sup>3</sup>		2,351	
Cylinder bore mm		86.5	
Piston stroke mm		100.0	
Compression ratio		11.5	
Valve timing	Intake valve	Opens (BTDC)	16°
		Closes (ABDC)	60°
	Exhaust valve	Opens (BBDC)	56°
		Closes (ATDC)	16°
Lubrication system		Pressure feed, full-flow filtration	
Oil pump type		Involute gear type	

**NOTE**

GDI is a trademark of Mitsubishi Motors Corporation.

# 1. SPECIFICATIONS

## SERVICE SPECIFICATIONS

Items			Standard value	Limit
<b>Timing belt</b>				
Auto-tensioner rod projection length mm			12	-
Auto-tensioner rod pushed-in amount [when pushed with a force of 98 - 196 N] mm			1.0 or less	-
<b>Rocker arms and camshaft</b>				
Camshaft cam height mm	4G63 SOHC	Intake	37.39	36.89
		Exhaust	37.14	36.64
	4G64 SOHC	Intake	37.39	36.89
		Exhaust	36.83	36.33
Lash adjuster leak down time [diesel fuel at 15 - 20°C] seconds/mm			3 - 20/1.0	-
Camshaft journal outer diameter mm			45	-
<b>Rocker arms and camshaft (GDI)</b>				
Camshaft cam height mm	Intake		35.79	35.29
	Exhaust		37.14	36.64
Lash adjuster leak down time [diesel fuel at 15 - 20°C] seconds/mm			3 - 20/1.0	-
Camshaft journal outer diameter mm			26	-
<b>Cylinder head and valves</b>				
Cylinder head flatness of gasket surface mm			Less than 0.05	0.2
Cylinder head grinding limit of gasket surface mm Total resurfacing depth of both cylinder head and cylinder block			-	0.2
Cylinder head overall height mm	SOHC		120	-
	GDI		132	-
Cylinder head bolt shank length mm			-	Maximum 99.4
Valve thickness of valve head (margin) mm	SOHC	Intake	1.0	0.5
		Exhaust	1.2	0.7
	GDI	Intake	1.0	0.5
		Exhaust	1.5	1.0
Valve overall height mm	SOHC	Intake	112.30	111.80
		Exhaust	114.11	113.61
	GDI	Intake	105.5	105.0
		Exhaust	105.7	105.2
Valve stem outer diameter mm			6.0	-

Items			Standard value	Limit
Valve thickness to valve guide clearance mm	SOHC	Intake	0.02 - 0.05	0.10
		Exhaust	0.03 - 0.07	0.15
	GDI	Intake	0.02 - 0.05	0.10
		Exhaust	0.05 - 0.09	0.15
Valve face angle mm			45° - 45.5°	-
Valve spring free length mm	SOHC		51.0	50.0
	GDI		48.3	47.3
Valve spring load/installed height N/mm	SOHC		267/44.2	-
	GDI		294/40.0	-
Valve spring out-of-squareness	SOHC		2° or less	Maximum 4°
	GDI		1.5° or less	Maximum 4°
Valve seat valve contact width mm			0.9 - 1.3	-
Valve guide inner diameter mm	SOHC		6.0	-
	GDI		6.6	-
Valve guide projection from cylinder head upper surface mm	SOHC		14.0	-
	GDI		19.5	-
Valve stem projection mm	SOHC		49.30	49.80
	GDI	Intake	49.20	49.70
		Exhaust	48.40	48.90
Oversize rework dimensions of valve guide hole (SOHC) mm	0.05 Oversize diameter		11.05 - 11.07	-
	0.25 Oversize diameter		11.25 - 11.27	-
	0.50 Oversize diameter		11.50 - 11.52	-
Oversize rework dimensions of valve guide hole (GDI) mm	0.05 Oversize diameter		12.05 - 12.07	-
	0.25 Oversize diameter		12.25 - 12.27	-
	0.50 Oversize diameter		12.50 - 12.52	-
Intake oversize rework dimensions of valve seat hole (SOHC) mm	0.3 Oversize diameter		34.30 - 34.33	-
	0.6 Oversize diameter		34.60 - 34.63	-
Intake oversize rework dimensions of valve seat hole (GDI) mm	0.3 Oversize diameter		35.30 - 35.33	-
	0.6 Oversize diameter		35.60 - 35.63	-
Exhaust oversize rework dimensions of valve seat hole (SOHC) mm	0.3 Oversize diameter		34.30 - 34.33	-
	0.6 Oversize diameter		34.60 - 34.63	-
Exhaust oversize rework dimensions of valve seat hole (GDI) mm	0.3 Oversize diameter		33.30 - 33.33	-
	0.6 Oversize diameter		33.60 - 33.63	-

Items		Standard value	Limit
<b>Front case, counterbalance shaft and oil pan</b>			
Oil pump side clearance mm	Drive gear	0.08 - 0.14	-
	Driven gear	0.06 - 0.12	-
Oil pressure at curb idle speed kPa [Oil temperature is 75 to 90°C]		78 or more	-
<b>Piston and connecting rod</b>			
Piston outer diameter mm	4G63	85.0	-
	4G64	86.5	-
Piston ring side clearance mm	No. 1	0.02 - 0.06	0.1
	No. 2	0.02 - 0.06	0.1
Piston ring end gap mm	No. 1	0.25 - 0.35	0.8
	No. 2	0.40 - 0.55	0.8
	Oil ring side rail	0.10 - 0.40	1.0
Piston pin outer diameter mm		22.0	-
Piston pin press-in load N (Room temperature)		7,350 - 17,200	-
Crankshaft pin oil clearance mm		0.02 - 0.05	0.1
Connecting rod big end side clearance mm		0.10 - 0.25	0.4
<b>Crankshaft, flywheel and drive plate</b>			
Crankshaft end play mm		0.05 - 0.25	0.40
Crankshaft journal outer diameter mm		57.0	-
Crankshaft pin outer diameter mm		45.0	-
Crankshaft journal oil clearance mm		0.02 - 0.04	0.1
Bearing cap bolt shank length mm		-	Maximum 71.1
Piston to cylinder clearance mm		0.02 - 0.04	-
Cylinder block flatness of gasket surface mm		0.05	0.1
Cylinder block grinding limit of gasket surface mm Total resurfacing depth of both cylinder head and cylinder block		-	0.2
Cylinder block overall height mm	4G63	284	-
	4G64	290	-
Cylinder block inner diameter mm	4G63	85.0	-
	4G64	86.5	-
Cylindricity mm		0.01	-

## TORQUE SPECIFICATIONS

Items	Nm
<b>Alternator and ignition system</b>	
Water pump pulley	9
Adjusting bolt	10
Lock bolt	22
Alternator brace	23
Alternator pivot nut	44
Crankshaft pulley	25
Ignition coil (Multipoint fuel injection)	10
Spark plug	25
Distributor (Carburetor)	12
Camshaft position sensing cylinder (Multipoint fuel injection)	22
Camshaft position sensor support (Multipoint fuel injection)	14
Camshaft position sensor (Multipoint fuel injection)	10
Oil level gauge guide	13
Idler pulley bracket (M8) (Vehicle for Hong Kong)	22
Idler pulley bracket (M10) (Vehicle for Hong Kong)	49
Idler pulley (Vehicle for Hong Kong)	49
<b>Intake manifold (GDI)</b>	
Vacuum pipe and hose (Flange bolt)	11
Vacuum pipe and hose (Bolt, washer assembly)	8.8
Solenoid valve	8.8
Vacuum pipe	11
Throttle body	11
Intake manifold stay (M6)	8.8
Intake manifold stay (M8)	30
Air intake plenum resonator (Flange bolt)	11
Air intake plenum resonator (Bolt, washer assembly)	8.8
EGR valve	23
EGR valve support	23
Intake manifold	19
<b>Timing belt</b>	
Timing belt cover flange bolt	11



Items	Nm
Timing belt cover washer bolt	9
Power steering bracket	49
Crankshaft angle sensor (Multipoint fuel injection)	9
Tensioner arm	22
Tensioner puller	48
Auto tensioner	23
Idler pulley	35
Engine support bracket	49
Oil pump sprocket	54
Crankshaft bolt	118
Tensioner "B"	18
Counterbalance shaft sprocket	45
Camshaft sprocket bolt	88
<b>Exhaust manifold (GDI)</b>	
Exhaust manifold cover	13
Exhaust manifold (M10)	49
Exhaust manifold (M8)	29
Engine hanger	11
<b>Fuel and emission parts</b>	
Carburetor (Carburetor)	17
Fuel vapor separator (Carburetor)	23
Throttle body (Multipoint fuel injection)	18
EGR valve (Except General Export)	22
Injectors and delivery pipe (Multipoint fuel injection)	12
Fuel pressure regulator (Multipoint fuel injection)	9
<b>Fuel part (GDI)</b>	
Fuel low pressure pipe (M6)	8.8
Fuel low pressure pipe (M8)	18
Fuel pump return nipple	8.8
Clamp A	8.8
Fuel pipe bracket	11
Fuel feed pipe	11

Items	Nm
Fuel pump	4.9 → 17 ± 2
Harness bracket	8.8
Fuel return pipe	11
Fuel high pressure regulator	18
Fuel pressure sensor	18
Pump camshaft case	23
Injector holder	22
Delivery pipe and injector assembly	11
Engine hanger	11
<b>Water pump and intake manifold</b>	
Engine coolant temperature sensor	29
Engine coolant temperature gauge unit	11
Water inlet fitting	13
Thermostat housing	24
Water inlet pipe	13
Water pump	14
Oil level gauge guide	14
Intake manifold stay	31
Intake manifold	19
Engine hanger	11
Detonation sensor (Multipoint fuel injection)	23
<b>Water pump and water hose (GDI)</b>	
Engine coolant temperature sensor	29
Engine coolant temperature gauge unit	11
Water inlet fitting	12
Water outlet fitting	12
Thermostat housing	23
Water inlet pipe	12
Water pump	13
Knock sensor	22
<b>Exhaust manifold</b>	
Exhaust manifold cover	13

Items	Nm
Heat protector	13
Exhaust manifold (M8)	29
Exhaust manifold (M10)	49
Water outlet fitting	13
<b>Rocker arms and camshaft</b>	
Rocker cover	3.4
Rocker arm shaft	31
<b>Rocker arms and camshafts (GDI)</b>	
Camshaft position sensor	8.8
Cover	9.8
Camshaft position sensing cylinder	21
Camshaft position sensing support	13
Beam camshaft cap	20
<b>Cylinder head and valves</b>	
Cylinder head bolt [Tighten to 78 Nm and then completely loosen before finally tightening with above procedure.]	20 + 90° + 90°
<b>Front case, counterbalance shaft and oil pan</b>	
Drain plug	39
Oil pan	6.9
Oil level sensor (For Europe)	8.8
Stiffener (For Europe)	21
Oil screen	18
Oil pressure switch (4G63)	19
Oil pressure switch (4G64)	9.8
Relief plug	44
Oil filter bracket	18
Plug	23
Flange bolt	36
Oil pump cover bolt	16
Oil pump cover screw	9.8
Front case	23
Transmission stay (GDI engine)	21
Oil level gauge guide	12

Items	Nm
Oil pan lower	6.9
Baffle plate	6.9
Oil pan upper	6.9
<b>Piston and connecting rod</b>	
Connecting rod cap	20 + 90° → 100°
<b>Crankshaft, flywheel and drive plate</b>	
Flywheel bolt	132
Drive plate bolt	132
Rear plate	11
Bell housing cover	8.8
Oil seal case bolt	11
Bearing cap bolt	25 + 90° → 100°

## NEW TIGHTENING METHOD - BY USE OF BOLTS TO BE TIGHTENED IN PLASTIC AREA

A new type of bolts, to be tightened in plastic area, is currently used some parts of the engine. The tightening method for the bolts is different from the conventional one. Be sure to observe the method described in the text when tightening the bolts.

Service limits are provided for the bolts. Make sure that the service limits described in the text are strictly observed.

- Areas where the bolts are in use:
  - (1) Cylinder head bolts
  - (2) Main bearing cap bolts
  - (3) Connecting rod cap bolts
- Tightening method  
After tightening the bolts to the specified torque, tighten them another 90° or 180° (twice 90°). The tightening method varies on different areas. Observe the tightening method described in the text.

## SEALANTS

Item	Specified sealant	Quantity
Cam position sensor support	Mitsubishi Genuine Part No. MD970389 or equivalent	As required
Engine coolant temperature sensor	3M Nut Locking Part No. 4171 or equivalent	As required
Engine coolant temperature gauge unit	3M ATD Part No. 8660 or equivalent	As required
Thermostat case	Mitsubishi Genuine Part No. MD970389 or equivalent	As required
Water outlet fitting	Mitsubishi Genuine Part No. MD970389 or equivalent	As required
Beam camshaft cap	Mitsubishi Genuine Part No. MD970389 or equivalent	As required
Cylinder head	Mitsubishi Genuine Part No. MD970389 or equivalent	As required
Oil pressure switch	3M ATD Part No. 8660 or equivalent	As required
Oil pan	Mitsubishi Genuine Part No. MD970389 or equivalent	As required
Oil seal case	Mitsubishi Genuine Part No. MD970389 or equivalent	As required

## FORM-IN-PLACE GASKET

The engine has several areas where the form-in-place gasket (FIPG) is in use. To ensure that the gasket fully serves its purpose, it is necessary to observe some precautions when applying the gasket. Bead size, continuity and location are of paramount importance. Too thin a bead could cause leaks. Too thick a bead, on the other hand, could be squeezed out of location, causing blocking or narrowing of the fluid feed line. To eliminate the possibility of leaks from a joint, therefore, it is absolutely necessary to apply the gasket evenly without a break, while observing the correct bead size.

The FIPG used in the engine is a room temperature vulcanisation (RTV) type and is supplied in a 100-gram tube (Part No. MD970389). Since the RTV hardens as it reacts with the moisture in the atmospheric air, it is normally used in the metallic flange areas. The FIPG, Part No. MD970389, can be used for sealing both engine oil and coolant, while Part No. MD997110 can only be used for engine oil sealing.

### Disassembly

The parts assembled with the FIPG can be easily disassembled without use of a special method. In some cases, however, the sealant between the joined surfaces may have to be broken by lightly striking with a mallet or similar tool. A flat and thin gasket scraper may be lightly hammered in between the joined surfaces. In this case, however, care must be taken to prevent damage to the joined surfaces. For removal of the oil pan, the special tool "Oil Pan Remover" (MD998727) is available. Be sure to use the special tool to remove the oil pan. <Except aluminium die-cast oil pans>

### Surface Preparation

Thoroughly remove all substances deposited on the gasket application surfaces, using a gasket scraper or wire brush. Check to ensure that the surfaces to which the FIPG is to be applied is flat. Make sure that there are no oils, greases and foreign substances deposited on the application surfaces. Do not forget to remove the old sealant remained in the bolt holes.



### Form-in-Place Gasket Application



When assembling parts with the FIPG, you must observe some precautions, but the procedure is very simple as in the case of a conventional pre-cut gasket.

Applied FIPG bead should be of the specified size and without breaks. Also be sure to encircle the bolt hole circumference with a completely continuous bead. The FIPG can be wiped away unless it is hardened. While the FIPG is still moist (in less than 15 minutes), mount the parts in position. When the parts are mounted, make sure that the gasket is applied to the required area only. In addition, do not apply any oil or water to the sealing locations or start the engine until a sufficient amount of time (about one hour) has passed after installation is completed.

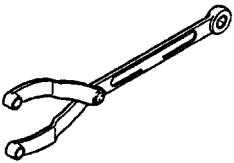
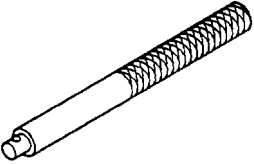
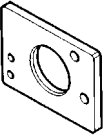
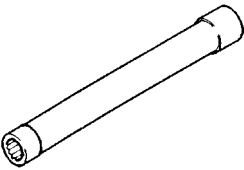
The FIPG application procedure may vary on different areas. Observe the procedure described in the text when applying the FIPG.

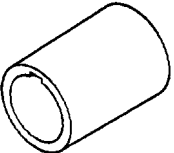
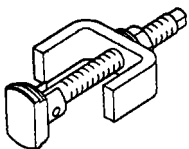
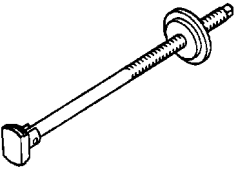
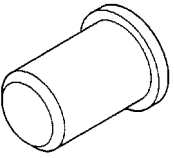
## 2. SPECIAL TOOLS

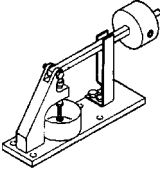
Tool	Number	Name	Use
	MB990767	Crankshaft pulley holder	Holding camshaft sprocket Use with MD998719.
	MD990938	Handle	Installation of crankshaft rear oil seal Use with MD998776.
	MB991603	Silent shaft bearing puller stopper	Guide stopper for removal and installation of counterbalance shaft rear bearing Use with MD998372.
	MB991654	Cylinder head bolt wrench (12)	Removal and installation of cylinder head bolt
	MD998162	Plug wrench	Removal and installation of front case cap plug Use with MD998783.
	MD998285	Crankshaft front oil seal guide	Guide for installation of crankshaft front oil seal Use with MD998375.
	MD998371	Silent shaft bearing puller	Removal of counterbalance shaft front bearing
	MD998372	Silent shaft bearing puller	Removal of counterbalance shaft rear bearing
	MD998375	Crankshaft front seal installer	Installation of crankshaft front oil seal

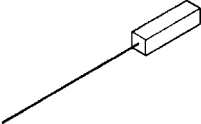
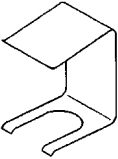
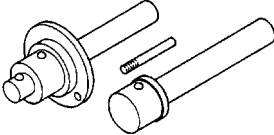
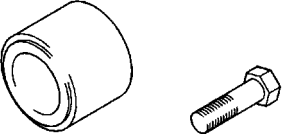
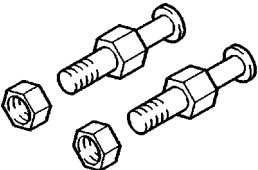
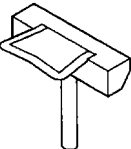
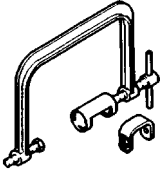
Tool	Number	Name	Use
	MD998440	Leak down tester	Leak down test of lash adjuster
	MD998441	Lash adjuster retainer	Air bleeding of lash adjuster
	MD998442	Lash adjuster wire	Air bleeding of lash adjuster
	MD998443	Lash adjuster holder	Retainer for holding lash adjuster in rocker arm at time of removal and installation of rocker shaft assembly
	MD998705	Silent shaft bearing installer	Installation of counterbalance shaft front and rear bearing
	MD998713	Camshaft oil seal installer	Installation of camshaft oil seal
	MD998719	Pulley holder pin	Holding camshaft sprocket Use with MB990767.
	MD998727	Oil pan remover	Removal of oil pan
	MD998735	Valve spring compressor	Removal and installation of valve and related parts

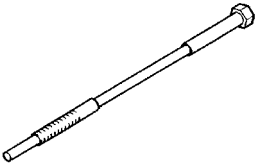
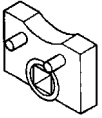
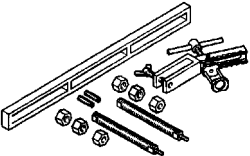
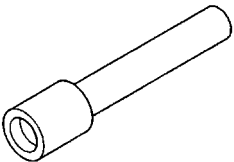
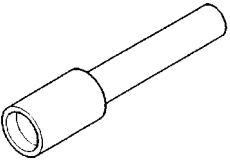
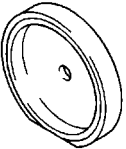
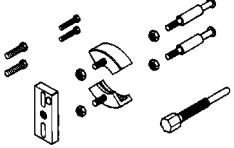
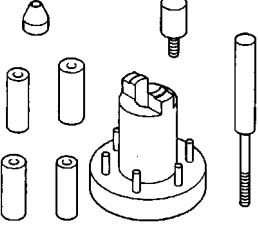
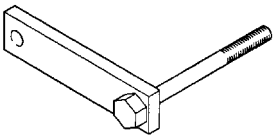

Tool	Number	Name	Use
	MD998738	Set screw	Adjustment of timing belt tension
	MD998767	Tensioner puller socket wrench	Adjustment of timing belt tension
	MD998772	Valve spring compressor	Removal and installation of valve and related parts
	MD998774	Valve stem seal installer	Installation of valve stem seal
	MD998775	Valve stem seal installer	Installation of valve stem seal
	MD998776	Crankshaft rear oil seal installer	Installation of crankshaft rear oil seal Use with MB990938.
	MD998778	Crankshaft sprocket puller	Removal of crankshaft sprocket
	MD998780	Piston setting tool	Removal and installation of piston pin
	MD998781	Flywheel stopper	Holding of flywheel and drive plate

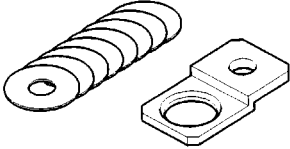
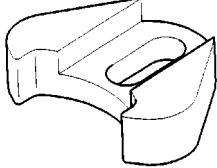
Tool	Number	Name	Use
	MD998783	Plug wrench retainer	Removal and installation of front case cap plug
	MD998785	Sprocket stopper	Holding silent shaft sprocket

### 3. ALTERNATOR AND IGNITION SYSTEM

#### REMOVAL AND INSTALLATION <CARBURETOR>

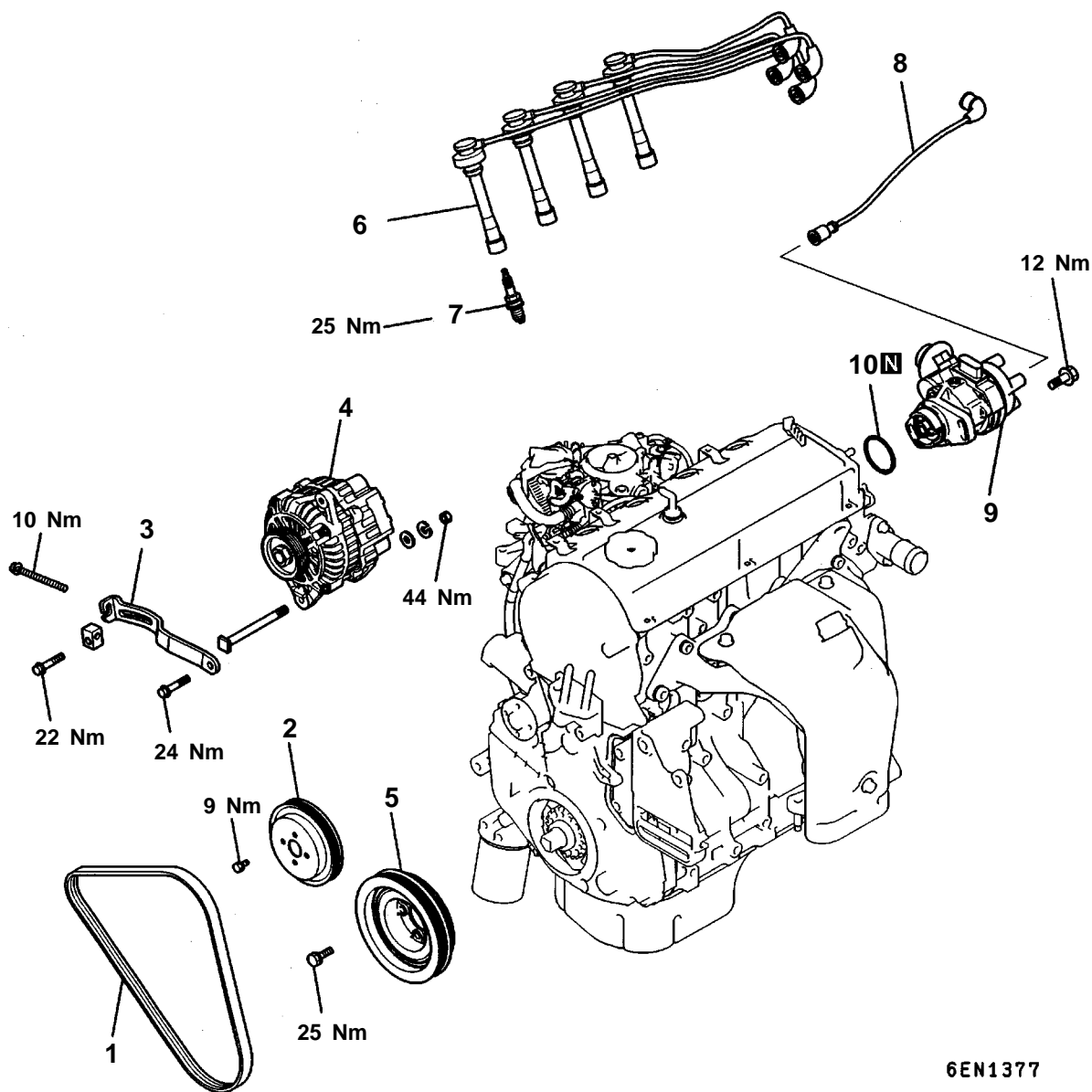

6EN1377

#### Removal steps

1. Drive belt
2. Water pump pulley
3. Alternator brace
4. Alternator
5. Crankshaft pulley
6. Spark plug cable
7. Spark plug
8. High tension cable
9. Distributor assembly
10. O-ring



## REMOVAL AND INSTALLATION &lt;MULTIPOINT FUEL INJECTION&gt;

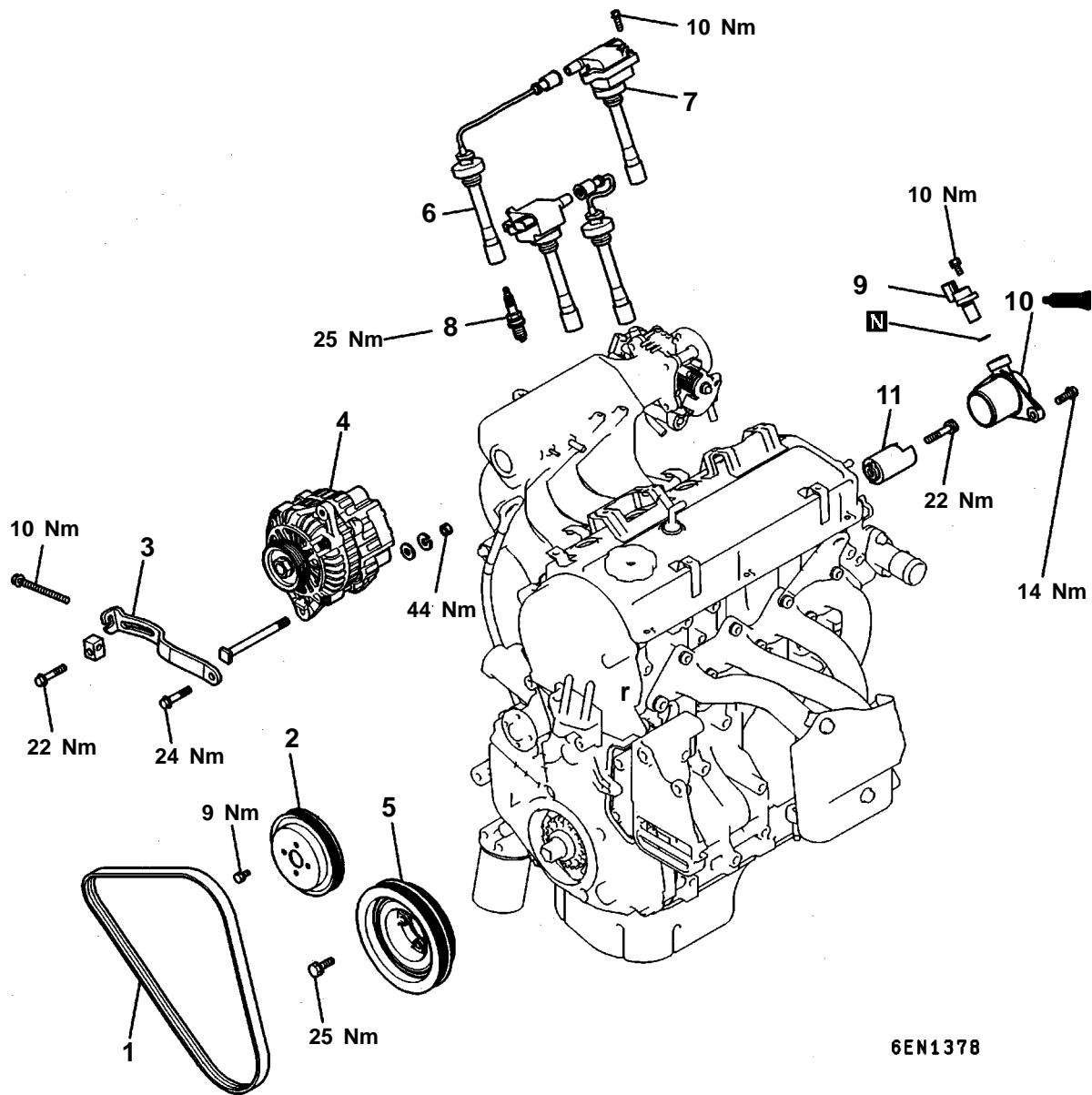

6EN1378

**Removal steps**

1. Drive belt
2. Water pump pulley
3. Alternator brace
4. Alternator
5. Crankshaft pulley
6. Spark plug cable

7. Ignition coil assembly
8. Spark plug
9. Camshaft position sensor
- ▶◀ 10. Camshaft position sensing support
11. Camshaft position sensing cylinder

REMOVAL AND INSTALLATION (GDI)

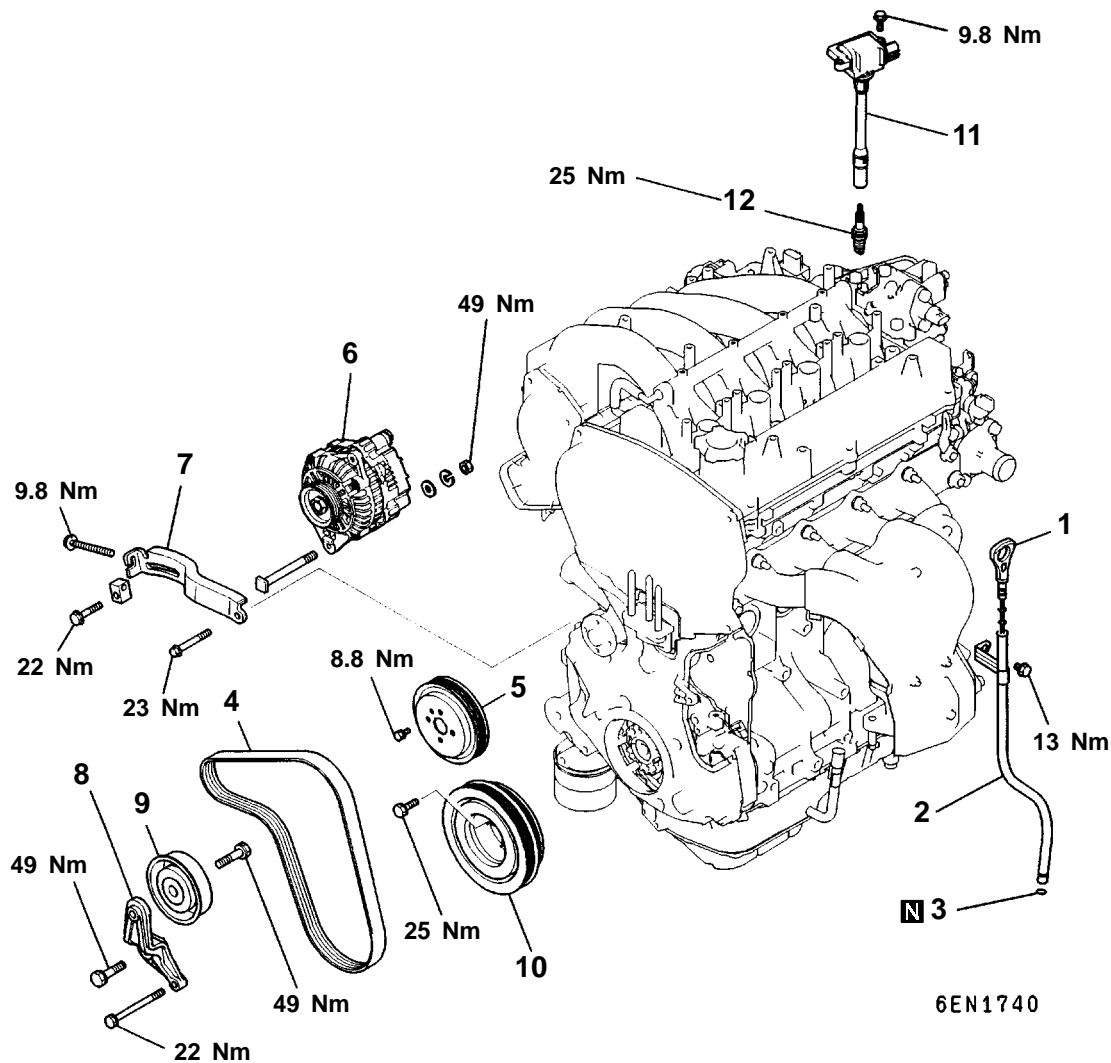

6EN1740

Removal steps

- |                          |  |
|--------------------------|--|
| 1. Oil level gauge       | 8. Idler pulley bracket<br>(Vehicle for Hong Kong) |
| 2. Oil level gauge guide | 9. Idler pulley<br>(Vehicle for Hong Kong)         |
| 3. O-ring                | 10. Crankshaft pulley                              |
| 4. Drive belt            | 11. Ignition coil                                  |
| 5. Water pump pulley     | 12. Spark plug                                     |
| 6. Alternator            |  |
| 7. Alternator brace      |  |

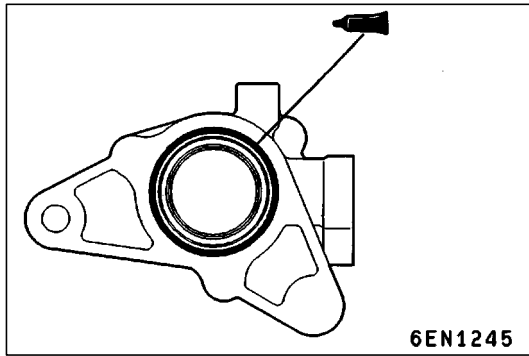

## INSTALLATION SERVICE POINTS

### ▶A◀ CAMSHAFT POSITION SENSOR SUPPORT INSTALLATION

- (1) Apply a 3 mm bead of form-in-place gasket (FIPG) to the area shown.

#### Specified sealant:

**Mitsubishi Genuine Part No. MD970389 or equivalent**

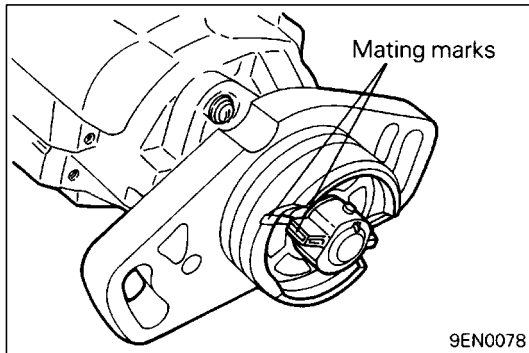

### ▶B◀ DISTRIBUTOR ASSEMBLY INSTALLATION

- (1) Turn the crankshaft to bring No. 1 cylinder to the top dead center on compression stroke.
- (2) Align the mating marks on the distributor housing with that of the coupling key.

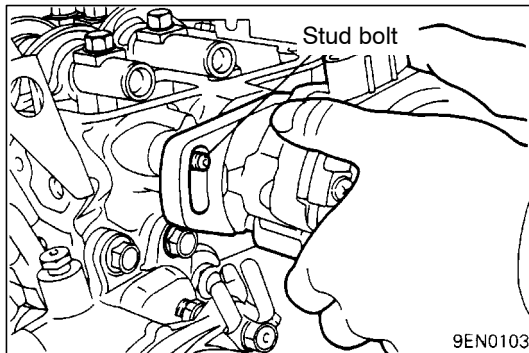

- (3) Install the distributor assembly on the engine while aligning the stud bolt used for securing the distributor with the slot in the mounting flange of the distributor.

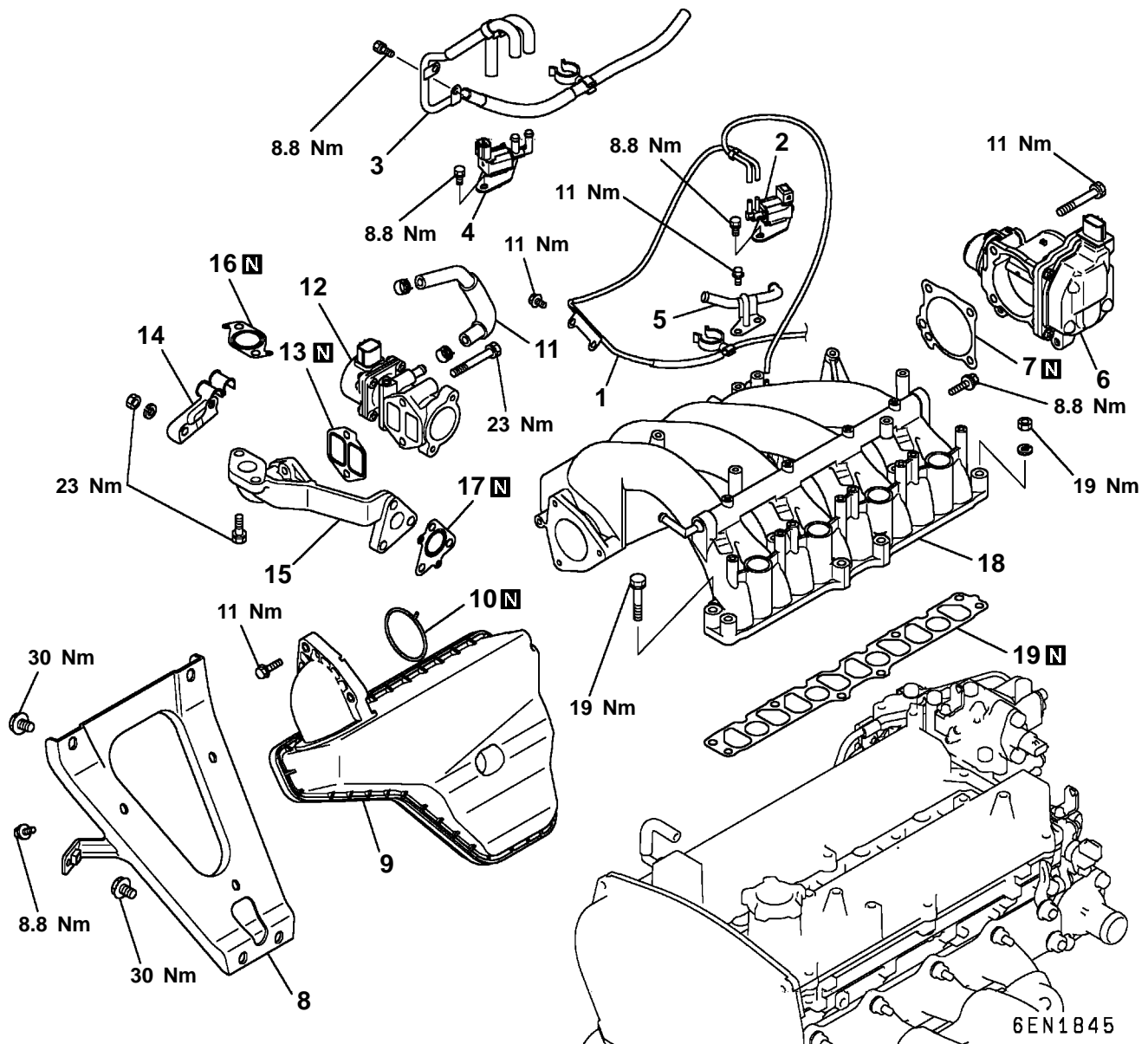
**3a. INTAKE MANIFOLD (GDI)****REMOVAL AND INSTALLATION (SPACE WAGON)****Removal steps**

1. Vacuum pipe and hose  
(1999 model vehicles for Hong Kong)
2. Solenoid valve (1999 model vehicles for Hong Kong)
3. Vacuum pipe and hose  
(Vehicles for Europe and 2000 model vehicles for Hong Kong)
4. Solenoid valve  
(Vehicles for Europe and 2000 model vehicles for Hong Kong)
5. Vacuum pipe
6. Throttle body

- |     |                                |
|-----|--------------------------------|
| ▶D◀ | 7. Throttle body gasket        |
| ▶C◀ | 8. Intake manifold stay        |
| ▶B◀ | 9. Air intake plenum resonator |
|     | 10. Gasket                     |
|     | 11. Water hose                 |
|     | 12. EGR valve                  |
|     | 13. Gasket                     |
| ▶A◀ | 14. Hose clamp                 |
| ▶A◀ | 15. EGR support                |
| ▶A◀ | 16. Gasket                     |
|     | 17. Gasket                     |
|     | 18. Intake manifold            |
|     | 19. Gasket                     |

REMOVAL AND INSTALLATION (GALANT)

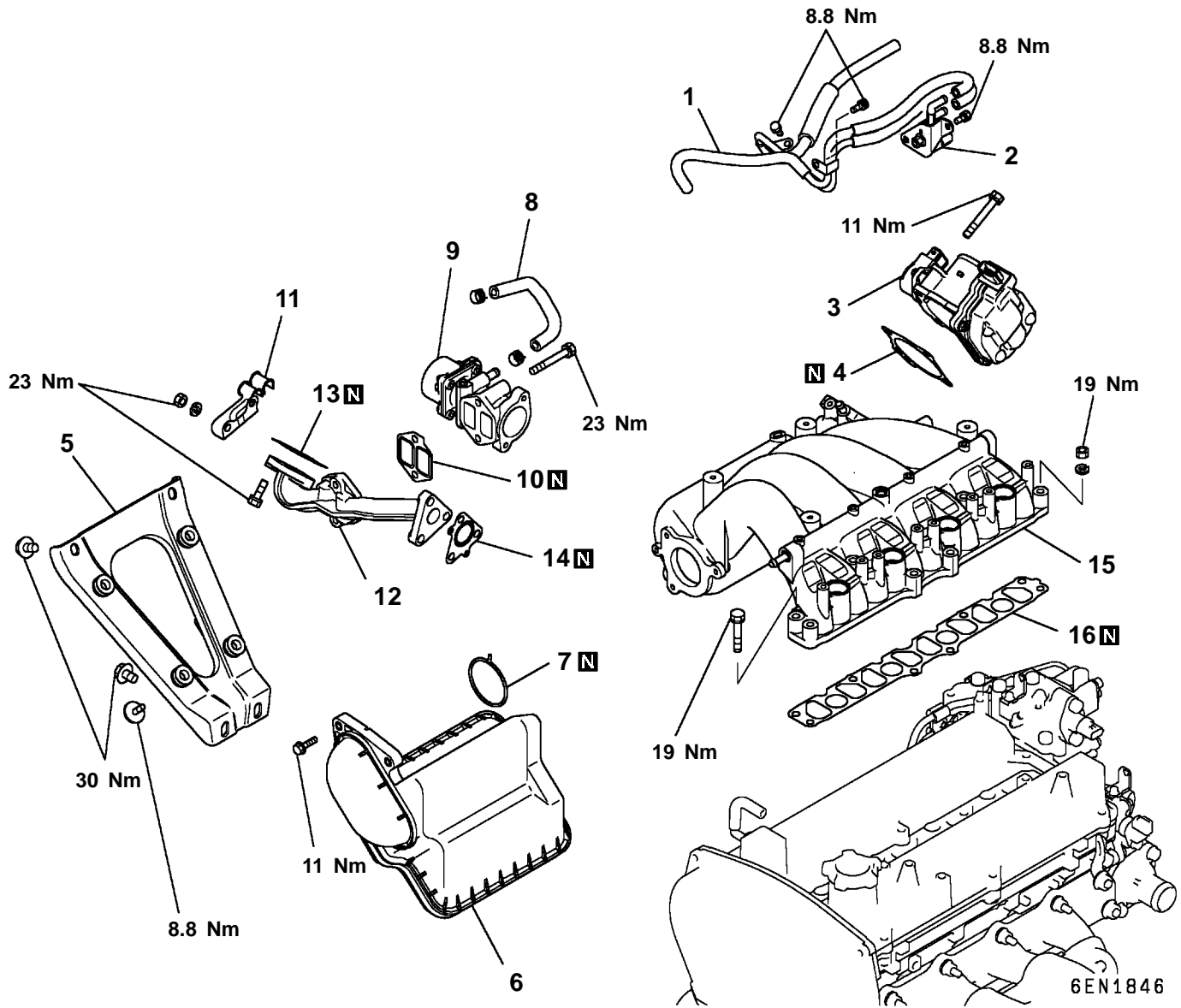

Removal steps

1. Vacuum pipe and hose
2. Solenoid valve
3. Throttle body
4. Throttle body gasket
5. Intake manifold stay
6. Air intake plenum resonator
7. Gasket
8. Water hose



9. EGR valve
10. Gasket
11. Hose clamp
12. EGR support
13. Gasket
14. Gasket
15. Intake manifold
16. Gasket



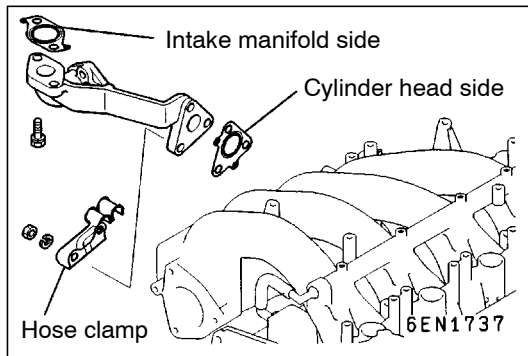

**INSTALLATION SERVICE POINTS****▶A◀ EGR SUPPORT / HOSE CLAMP / GASKET INSTALLATION**

- (1) Install the gasket, EGR support and hose clamp to the cylinder head in that order and tighten the fasteners temporarily.
- (2) Install the EGR support assembly to the intake manifold with the gasket attached on the mating surface, and tighten the fasteners to the specified torque.
- (3) Tighten the fasteners on the cylinder head side to the specified torque.

**▶B◀ AIR INTAKE PLENUM RESONATOR INSTALLATION**

- (1) Install the mounting bolts on the throttle body side without fail.

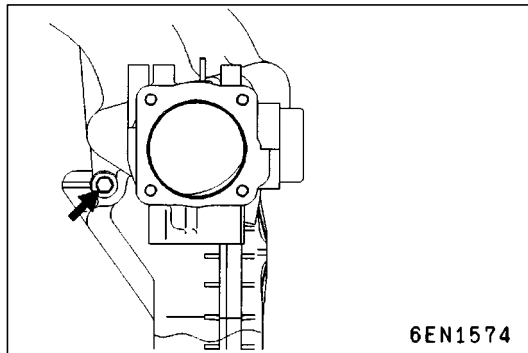
**▶C◀ INTAKE MANIFOLD STAY INSTALLATION**

- (1) Tighten the fasteners to the specified torque after confirming that the intake manifold stay is in close contact with the air intake plenum resonator and the cylinder block.

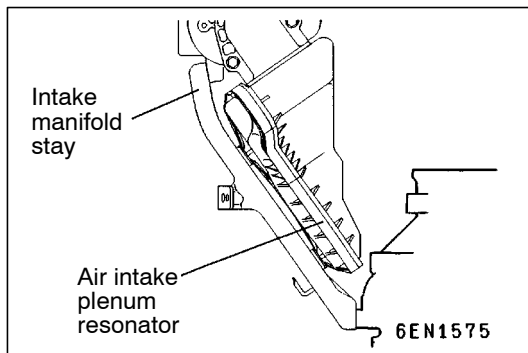
**▶D◀ THROTTLE BODY GASKET INSTALLATION**

- (1) Position the projection as shown in the illustration.

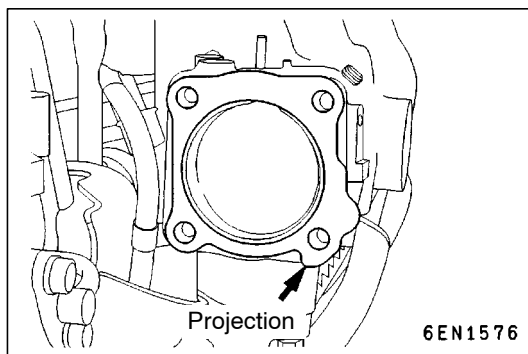

# 4. TIMING BELT

## REMOVAL AND INSTALLATION (SOHC)

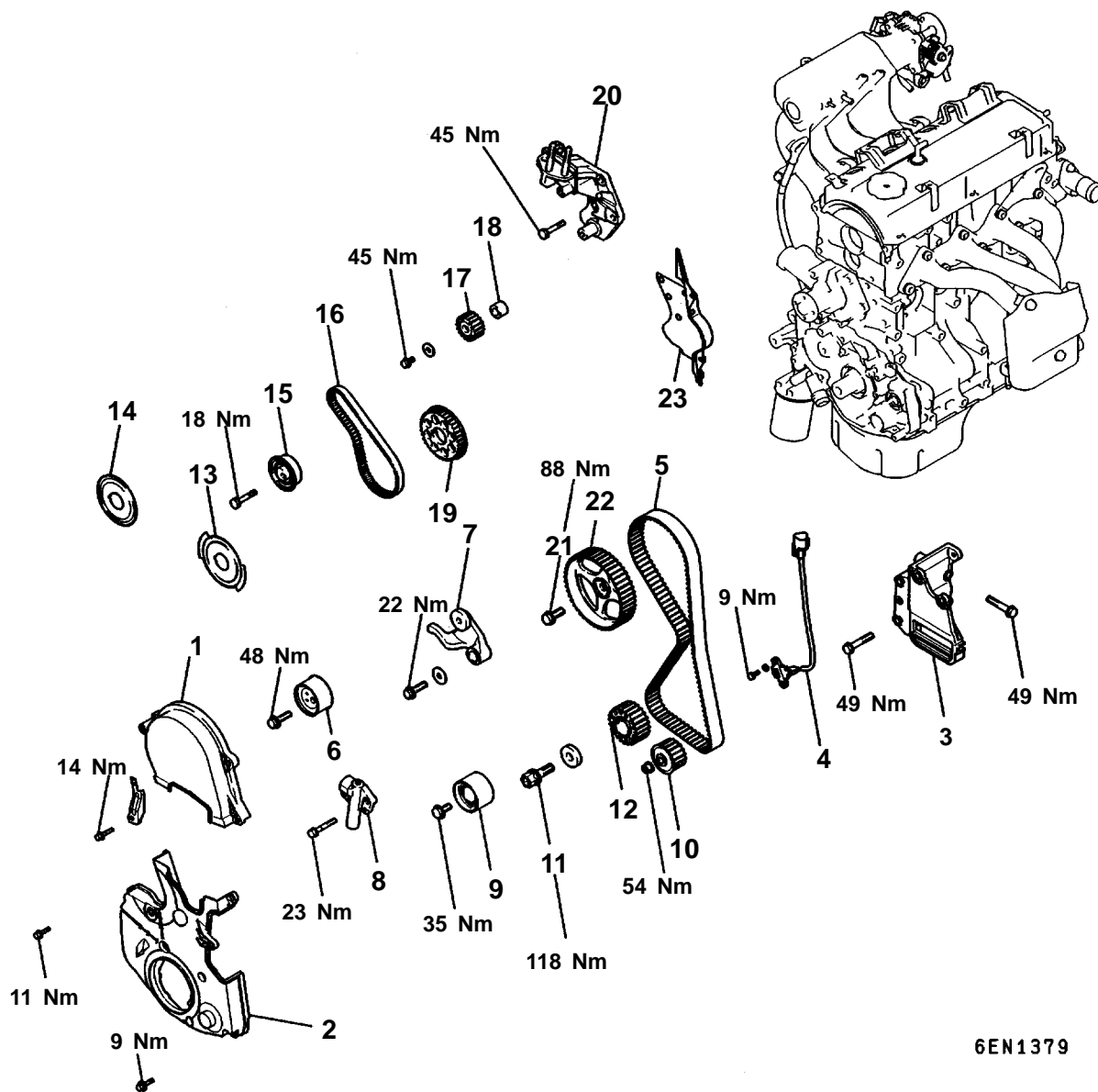

6EN1379

### Removal steps

- |     |   |     |     |     |  |
|-----|---|-----|-----|-----|--|
|     | 1. Timing belt front upper cover                          |     |     |     |  |
|     | 2. Timing belt front lower cover                          |     |     |     |  |
|     | 3. Power steering bracket                                 |     |     |     |  |
|     | 4. Crankshaft position sensor (Multipoint fuel injection) |     |     |     |  |
| ◀A▶ | 5. Timing belt  | ▶K▶ | ▶E▶ | ▶F▶ | 12. Crankshaft sprocket                |
|     | 6. Tensioner pulley                                       | ▶J▶ | ▶G▶ | ▶F▶ | 13. Flange (Multipoint fuel injection) |
|     | 7. Tensioner arm  |     |     | ▶E▶ | 14. Flange (Carburetor)                |
|     | 8. Auto tensioner   | ▶I▶ |     | ▶D▶ | 15. Tensioner "B"                      |
|     | 9. Idler pulley   |     |     |     | 16. Timing belt "B"                    |
| ▶C▶ | 10. Oil pump sprocket                                     | ▶H▶ |     |     | 17. Counterbalance shaft sprocket      |
| ▶D▶ | 11. Crankshaft bolt                                       | ▶G▶ |     | ▶C▶ | 18. Spacer                             |
|     |   |     |     | ▶A▶ | 19. Crankshaft sprocket "B"            |
|     |   |     |     |     | 20. Engine support bracket             |
|     |   |     |     |     | 21. Camshaft sprocket bolt             |
|     |   |     |     |     | 22. Camshaft sprocket                  |
|     |   |     |     |     | 23. Timing belt rear cover             |

REMOVAL AND INSTALLATION (GDI)

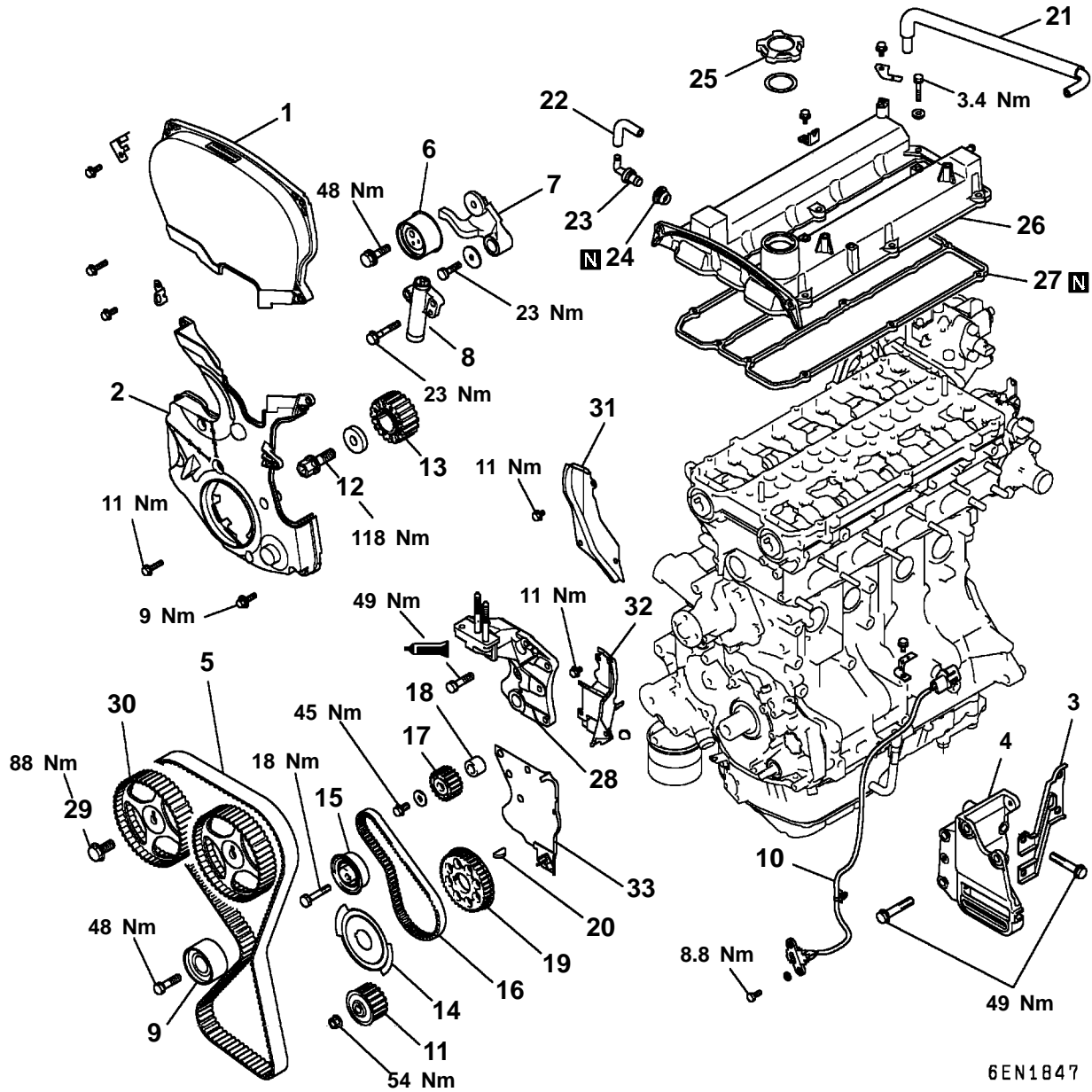

Removal steps

- |     |                                     |     |                                       |
|-----|-------------------------------------|-----|---------------------------------------|
|     | 1. Front upper cover                |     | 18. Spacer                            |
|     | 2. Front lower cover                | ◀H▶ | 19. Crankshaft sprocket B             |
|     | 3. Power steering pump bracket stay |     | 20. Crankshaft key                    |
|     | 4. Power steering bracket           |     | 21. Breather hose                     |
| ◀B▶ | 5. Timing belt                      | ▶D▶ | 22. PCV hose                          |
| ▶L▶ | 6. Tensioner pulley                 |     | 23. PCV valve                         |
| ▶J▶ | 7. Tensioner arm                    |     | 24. PCV valve gasket                  |
|     | 8. Auto tensioner                   |     | 25. Oil filler cap                    |
| ▶I▶ | 9. Idle pulley                      |     | 26. Rocker cover                      |
|     | 10. Crankshaft position sensor      |     | 27. Rocker cover gasket               |
| ◀C▶ | 11. Oil pump sprocket               |     | 28. Engine support bracket            |
| ▶H▶ | 12. Crankshaft bolt                 | ◀J▶ | 29. Camshaft sprocket bolt            |
| ▶D▶ | 13. Crankshaft sprocket             | ▶B▶ | 30. Camshaft sprocket                 |
| ▶E▶ | 14. Flange                          |     | 31. Timing belt rear right cover      |
|     | 15. Tensioner B                     |     | 32. Timing belt rear left upper cover |
| ◀F▶ | 16. Timing belt B                   |     | 33. Timing belt rear left lower cover |
| ▶F▶ | 17. Counterbalance shaft sprocket   |     |                                       |
| ▶G▶ |                                     |     |                                       |
| ▶E▶ |                                     |     |                                       |

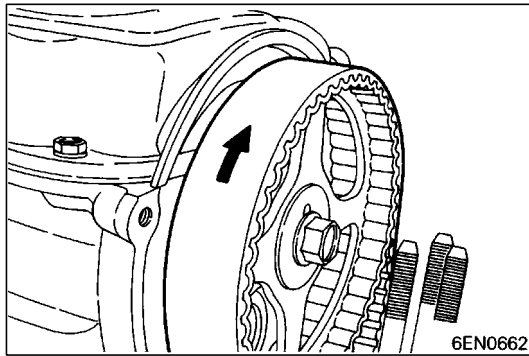

## REMOVAL SERVICE POINTS

### ◀A▶ TIMING BELT REMOVAL

- (1) Mark belt running direction for reinstallation.

#### NOTE

- (1) Water or oil on the belt shorten its life drastically, so the removed timing belt, sprocket, and tensioner must be free from oil and water. These parts should not be washed. Replace parts if seriously contaminated.
- (2) If there is oil or water on each part, check front case oil seals, camshaft oil seal and water pump for leaks.

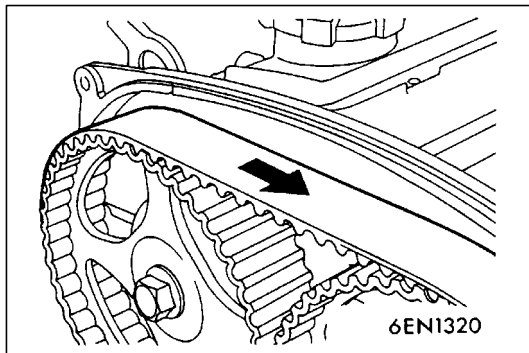

### ◀B▶ TIMING BELT REMOVAL

- (1) If the timing belt is to be reused, chalk an arrow mark on the back surface of the belt so that the belt can be reinstalled in the same direction.
- (2) Place the exhaust camshaft sprocket in a position where the timing mark for No. 1 cylinder is positioned about one tooth before the top dead center of the compression stroke.

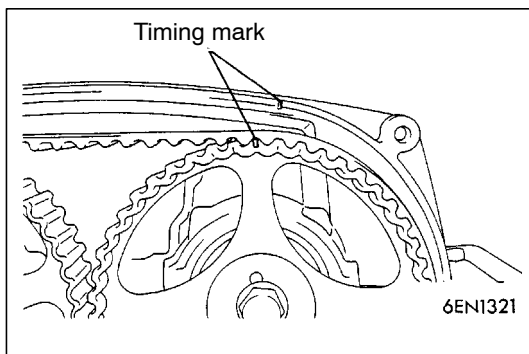

#### Caution

- The camshaft sprocket on the exhaust side can turn very easily because of the valve spring tension. Use care not to allow your fingers to get caught by the sprocket.

- (3) Loosen the lock nut of the tensioner pulley, then remove the timing belt.

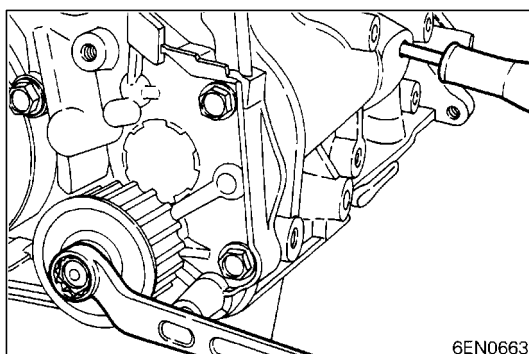

### ◀C▶ OIL PUMP SPROCKET REMOVAL

- (1) Remove the plug on the left side of cylinder block.
- (2) Insert a screwdriver (shank diameter 8 mm) to block the counterbalance shaft.
- (3) Remove the nut.
- (4) Remove the oil pump sprocket.

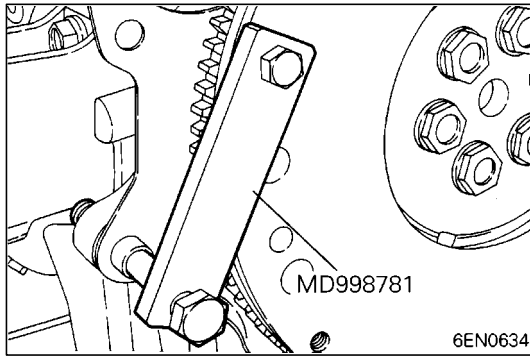

### ◀D▶ CRANKSHAFT BOLT LOOSENING

- (1) Hold the drive plate with the special tool as shown.
- (2) Remove the crankshaft bolt.

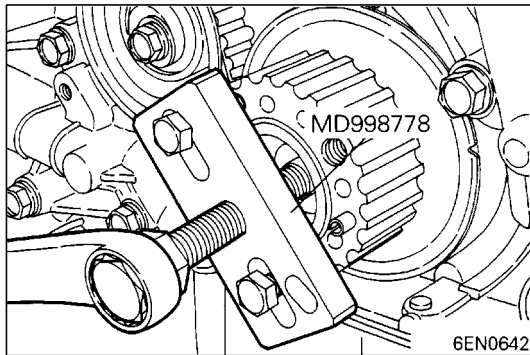

### ◀E▶ CRANKSHAFT SPROCKET REMOVAL

- (1) If it is difficult to remove the sprocket, use the special tool.

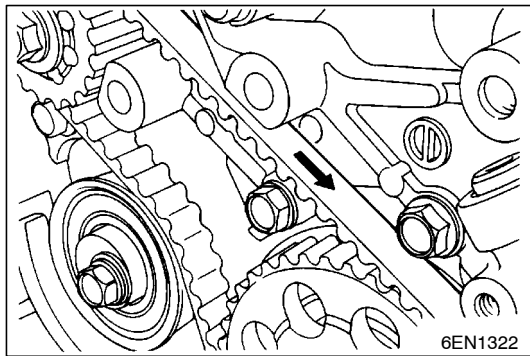

### ◀F▶ TIMING BELT "B" REMOVAL

- (1) Make a mark on the back of the timing belt indicating the direction of rotation so it may be reassembled in the same direction if it is to be reused.

#### NOTE

- (1) Water or oil on the belt shortens its life drastically, so the removed timing belt, sprocket, and tensioner must be free from oil and water. These parts should not be washed. Replace parts if seriously contaminated.
- (2) If there is oil or water on each part check front case oil seals, camshaft oil seal and water pump for leaks.

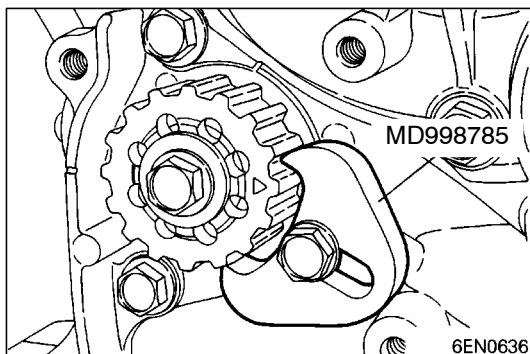

### ◀G▶ COUNTERBALANCE SHAFT SPROCKET REMOVAL

- (1) Set the special tool as shown to prevent the counterbalance shaft sprocket from turning together.
- (2) Loosen the bolt and remove the sprocket.

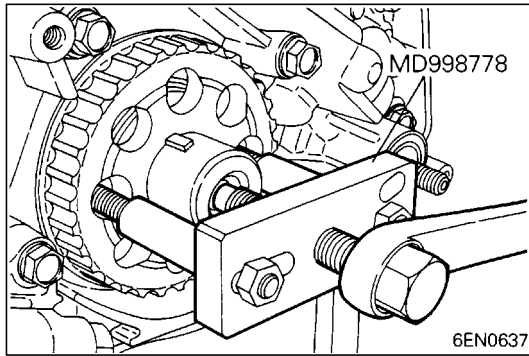

#### ◀H▶ CRANKSHAFT SPROCKET "B" REMOVAL

- (1) If it is difficult to remove the sprocket, use the special tool.

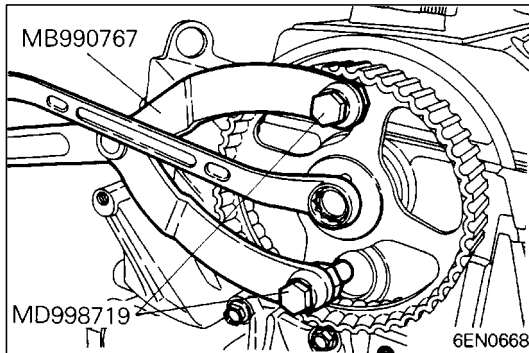

#### ◀I▶ CAMSHAFT SPROCKET BOLT LOOSENING

- (1) Using the special tools shown in the illustration, lock the camshaft sprocket in position.
- (2) Loosen the camshaft bolt.

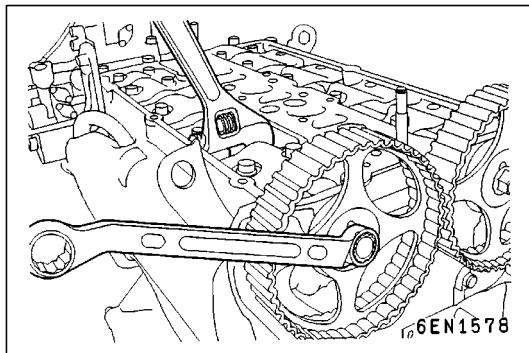

#### ◀J▶ CAMSHAFT SPROCKET BOLT LOOSENING

- (1) Use a wrench to hold the hexagonal part of the camshaft, and then remove the camshaft sprocket mounting bolt.

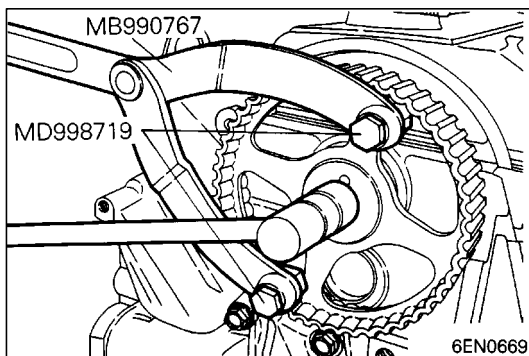

### INSTALLATION SERVICE POINTS

#### ▶A▶ CAMSHAFT SPROCKET BOLT TIGHTENING

- (1) Using the special tools shown in the illustration, lock the camshaft sprocket in position.
- (2) Tighten the camshaft sprocket bolt to the specified torque.

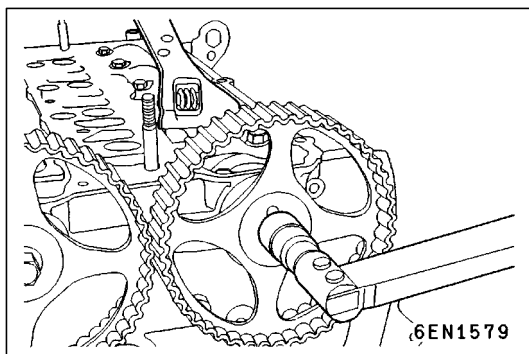

#### ▶B▶ CAMSHAFT SPROCKET BOLT TIGHTENING

- (1) Using a wrench, hold the camshaft at its hexagon and tighten the bolt to the specification.

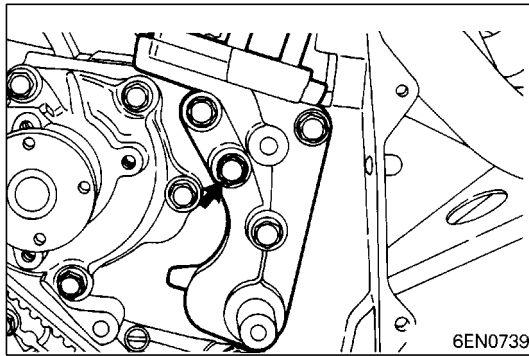

### ►C◄ ENGINE SUPPORT BRACKET INSTALLATION

- (1) Coat the bolts illustrated with sealant before tightening.  
**Specified sealant: 3M ATD Part No. 8660 or equivalent**

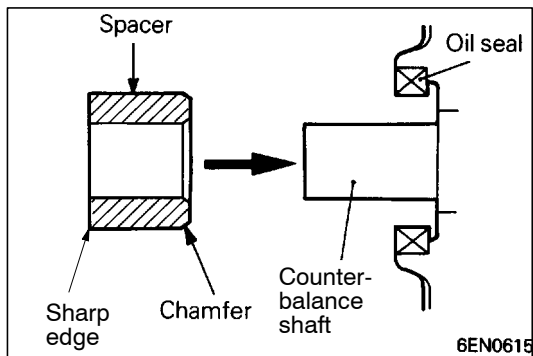

### ►D◄ SPACER INSTALLATION

- (1) Install the spacer with the chamfered end toward the oil seal.

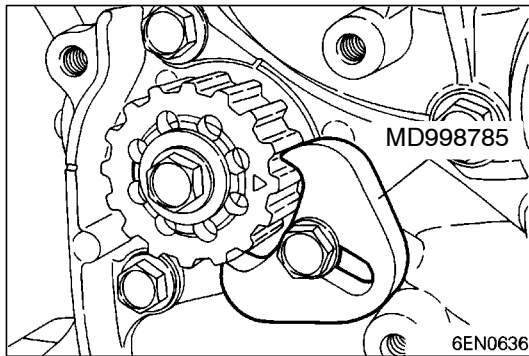

### ►E◄ COUNTERBALANCE SHAFT SPROCKET INSTALLATION

- (1) Install the counterbalance shaft sprocket and screw the bolt.
- (2) Install special tool MD998785 as shown in the illustration to lock the counterbalance shaft.
- (3) Tighten the bolt, and then remove the special tool.

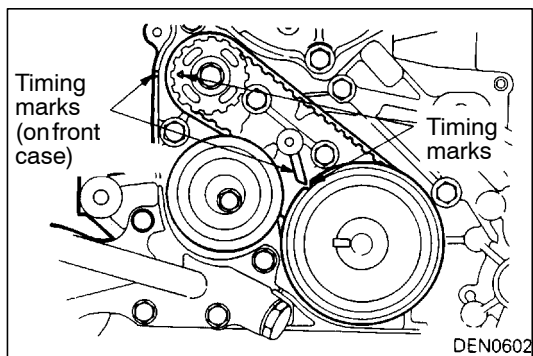

### ►F◄ TIMING BELT "B" INSTALLATION

- (1) Align timing marks on the crankshaft sprocket "B" and counterbalance shaft sprocket with the marks on the front case respectively.
- (2) Install the timing belt "B" on the crankshaft sprocket "B" and counterbalance shaft sprocket. There should be no slack on the tension side.

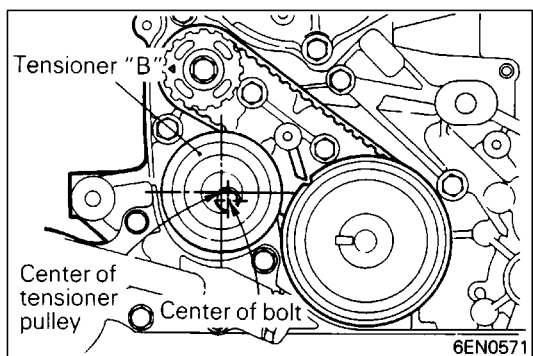

- (3) Make sure that the relationship between the tensioner pulley center and the bolt center is as shown in the illustration.

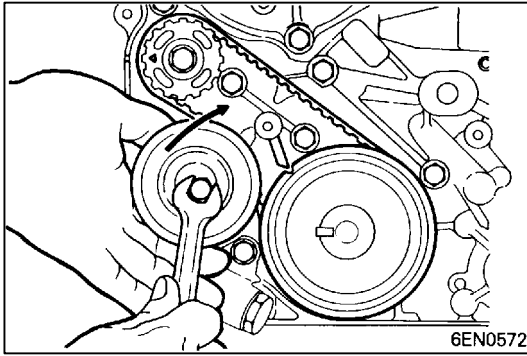

- (4) Move the tensioner "B" in the direction of arrow while lifting with a finger to give a sufficient tension to the tension side of timing belt. In this condition, tighten bolt to secure tensioner "B". When the bolt is tightened, use care to prevent shaft from turning together. If shaft is turned together, belt will be overtensioned.

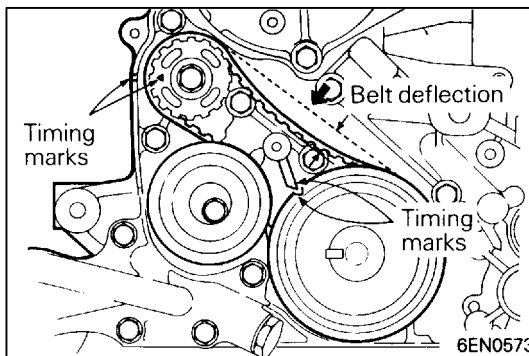

- (5) Check to ensure that timing marks on sprockets and front case are in alignment.
- (6) Press with index finger the center of span on the tension side of timing belt "B". The bolt must deflect 5 - 7 mm.

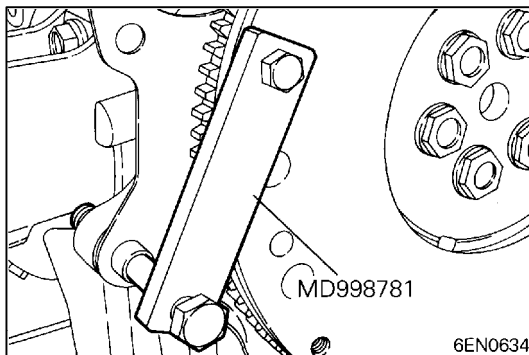

#### ►G◄ CRANKSHAFT BOLT TIGHTENING

- (1) Using the special tool, hold the flywheel or drive plate.
- (2) Install the crankshaft pulley in position.

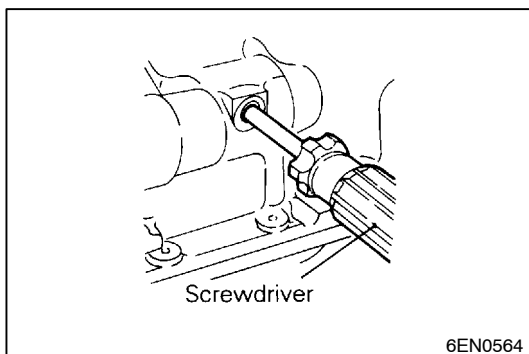

#### ►H◄ OIL PUMP SPROCKET INSTALLATION

- (1) Insert a Phillips screwdriver (shank diameter 8 mm shaft) through the plug hole on the left side of the cylinder block to block the left counterbalance shaft.
- (2) Install the oil pump sprocket.
- (3) Apply a proper amount of engine oil to the bearing surfaces of the nuts.
- (4) Tighten the nuts to the specified torque.

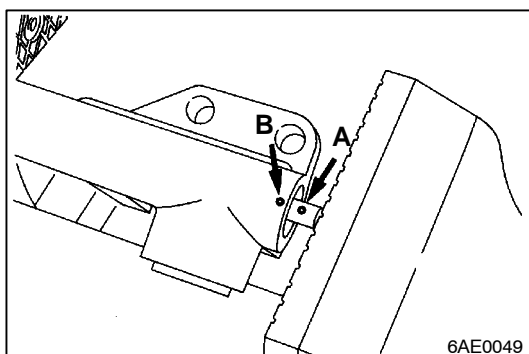

#### ►I◄ AUTO TENSIONER INSTALLATION

- (1) If the auto tensioner rod is in its fully extended position, reset it as follows.
- (2) Clamp the auto-tensioner in the vise with soft jaws.
- (3) Push in the rod little by little with the vise until the set hole A in the rod is aligned with the hole B in the cylinder.



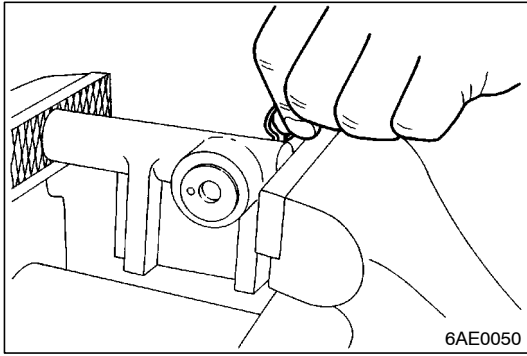

- (4) Insert a wire (1.4 mm in diameter) into the set holes.
- (5) Unclamp the auto tensioner from the vise.

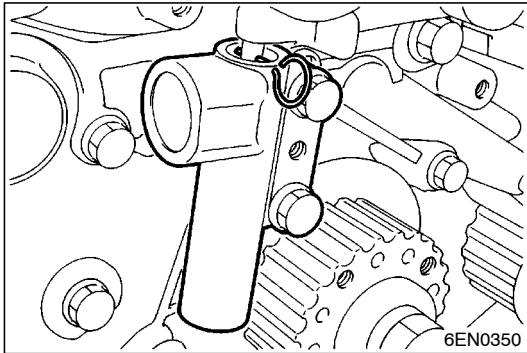

- (6) Install the auto tensioner to front case and tighten to the specified torque.

**Caution**

- Leave the wire installed in the auto tensioner.

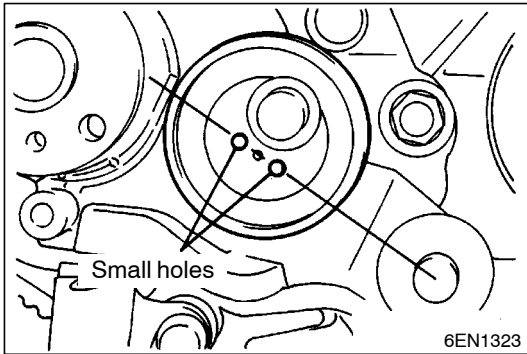

**►J◄ TENSIONER PULLEY INSTALLATION**

- (1) Install the tensioner pulley in such direction that its two small holes are arranged vertically.

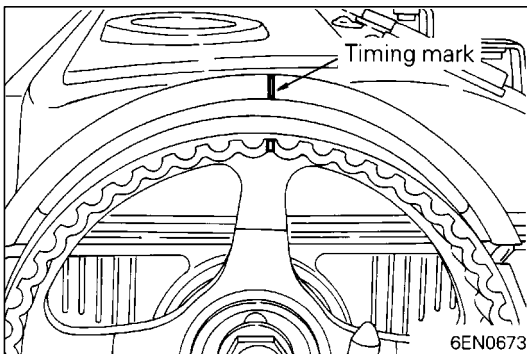

**►K◄ TIMING BELT INSTALLATION**

- (1) Check that the timing belt tensioner and spring have been installed in position. (See ►J◄)
- (2) Align timing mark on camshaft sprocket with timing mark on cylinder head.

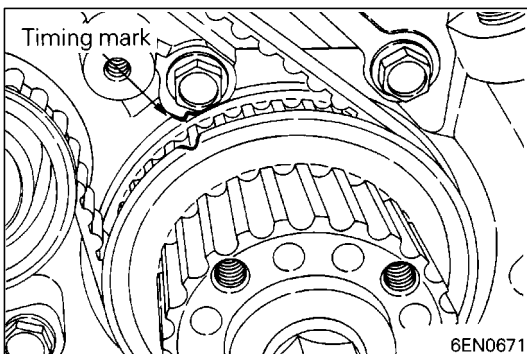

- (3) Align timing mark on crankshaft sprocket with timing mark on front case.

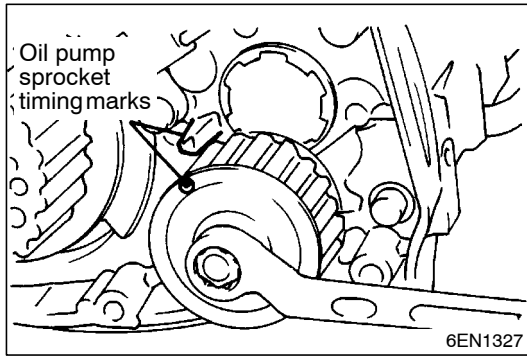

- (4) Align the timing mark on oil pump sprocket with its mating mark.

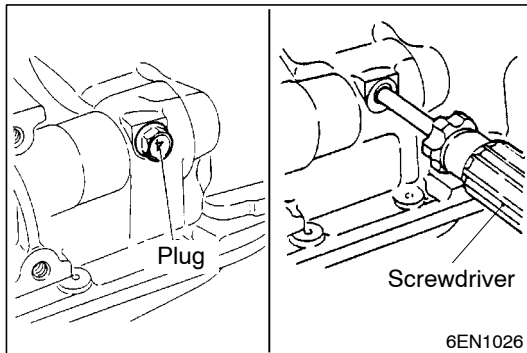

- (5) Remove the plug on cylinder block and insert a Phillips screwdriver (shank diameter 8 mm) through the hole (Engine with counterbalance shafts).  
If it can be inserted as deep as 60 mm or more, the timing marks are correctly aligned. If the inserted depth is only 20 - 25 mm, turn the oil pump sprocket one turn and realign timing marks. Then check to ensure that the screwdriver can be inserted 60 mm or more. Keep the screwdriver inserted until installation of timing belt is finished.

- (6) Install the timing belt on the crankshaft sprocket, idler pulley, camshaft sprocket, and tensioner pulley in that order.

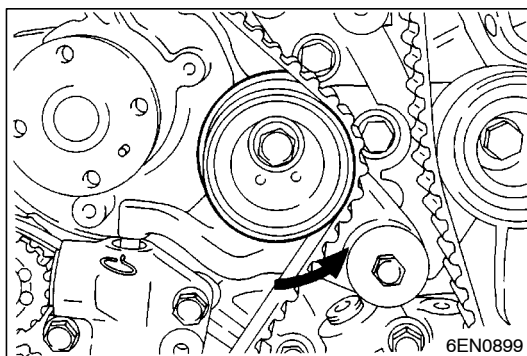

- (7) Lift up the tensioner pulley in the direction of arrow and tighten the center bolt.  
(8) Check that all timing marks are lined up.  
(9) Remove the screwdriver inserted in step (5) and fit the plug.  
(10) Give the crankshaft a quarter counterclockwise turn. Then, turn it clockwise until the timing marks are lined up again.

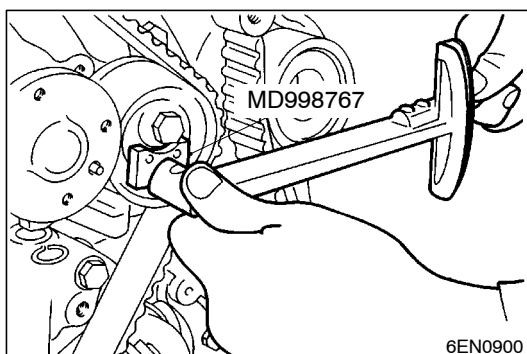

- (11) Install the special tools, Socket Wrench and Torque Wrench, on the tensioner pulley, and loosen the tensioner pulley center bolt.

**NOTE**

If the special tool is not available, use a commercially available torque wrench that is capable of measuring 0 - 5 Nm.

- (12) Torque to 3.5 Nm with the torque wrench.  
(13) Holding the tensioner pulley with the special tool and torque wrench, tighten the center bolt to specification.

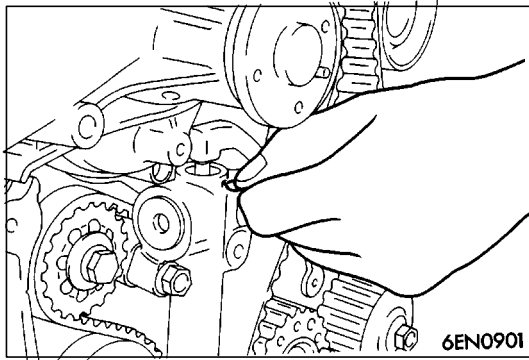

- (14) After giving two clockwise turns to the crankshaft, let it alone for approx. 15 minutes. Then, make sure that the auto tensioner setting wire moves freely.

**NOTE**

If the wire does not move freely, repeat step (10) above until it moves freely.

- (15) Remove the auto tensioner setting wire.

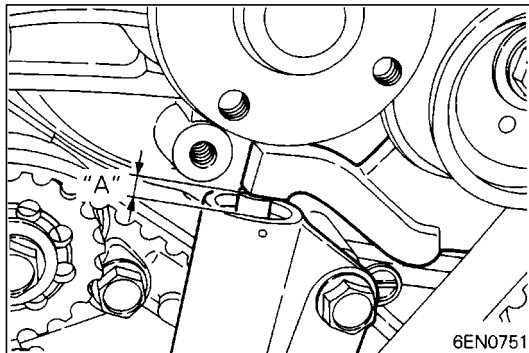

- (16) Measure the distance "A" (between the tensioner arm and auto tensioner body).

**Standard value: 3.8 - 4.5 mm**

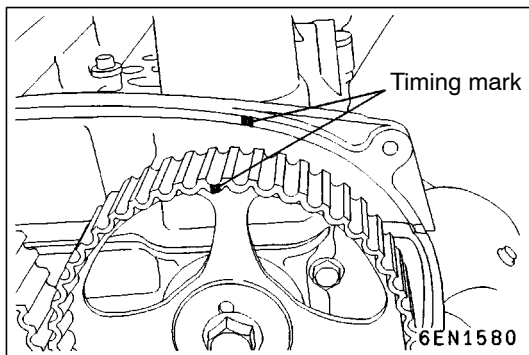

►L◄ **TIMING BELT INSTALLATION**

- (1) Place the exhaust side camshaft sprocket in a position where its timing mark is one tooth offset from the timing mark on the rocker cover in the counterclockwise direction.

**NOTE**

Even if the timing marks on the sprocket and the rocker cover are brought into alignment, the exhaust camshaft is forced back by the valve spring tension. It is stabilized at a position one tooth before the timing mark.

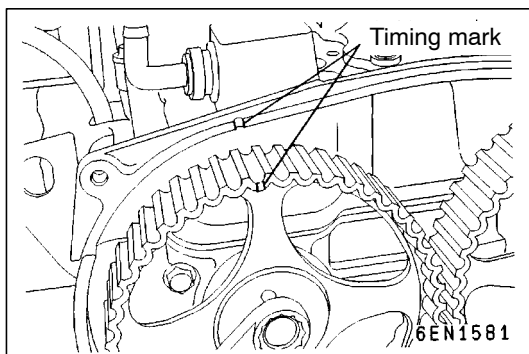

- (2) Align the timing mark on the intake side camshaft sprocket with that on the rocker cover.

**NOTE**

Even if the timing marks on the sprocket and the cover are brought into alignment, the intake camshaft is forced to turn one tooth in the clockwise direction by the valve spring tension and stabilized there.

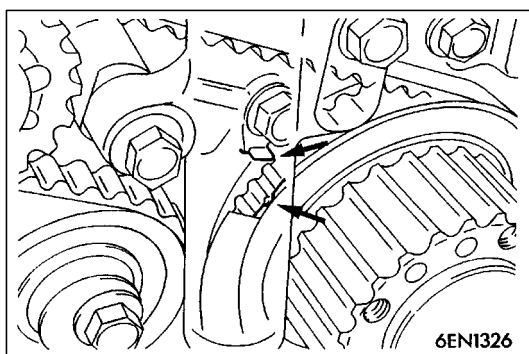

- (3) Place the timing mark on the crankshaft sprocket one tooth this side from the mated timing mark as in the case of the camshaft sprocket.

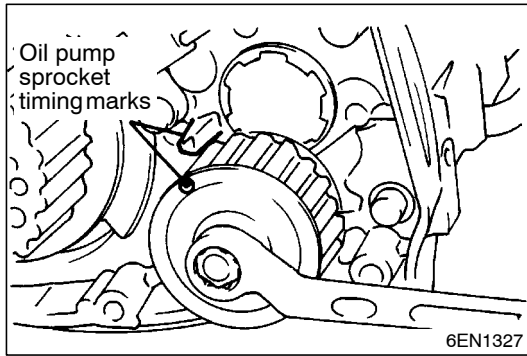

- (4) Align the timing mark on oil pump sprocket with its mating mark.

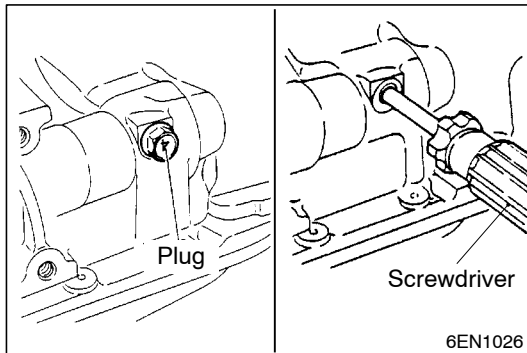

- (5) Remove the plug on cylinder block and insert a Phillips screwdriver (shank diameter 8 mm) through the hole (Engine with counterbalance shafts).  
If it can be inserted as deep as 60 mm or more, the timing marks are correctly aligned. If the inserted depth is only 20 - 25 mm, turn the oil pump sprocket one turn and realign timing marks. Then check to ensure that the screwdriver can be inserted 60 mm or more. Keep the screwdriver inserted until installation of timing belt is finished.

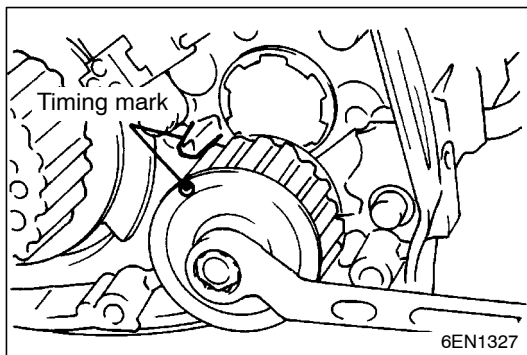

- (6) Remove the Phillips screwdriver. Place the oil pump sprocket in a position where its timing mark is one tooth offset from the mated timing mark in the counterclockwise direction.

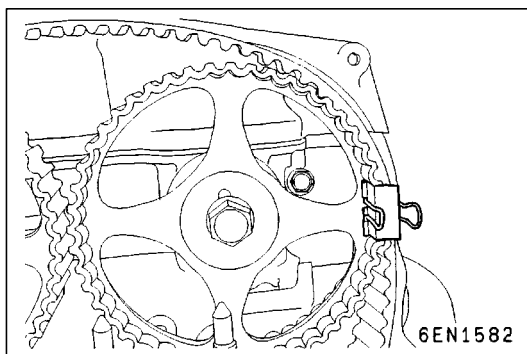

- (7) Fit the timing belt over the exhaust side camshaft sprocket, and secure it at the illustrated position using a paper clip.

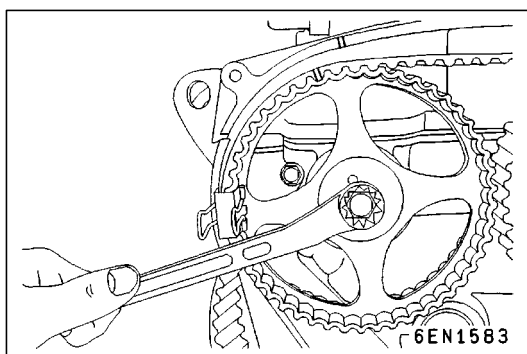

- (8) Turn the intake side camshaft sprocket as shown to a position where its timing mark is one tooth offset from the mated timing mark in the counterclockwise direction. Then, fit the timing belt over the sprocket and secure it with a paper clip.

#### NOTE

The intake camshaft will be turned a little clockwise by the valve spring tension and stabilized in position even if the belt is clipped at one tooth offset position.

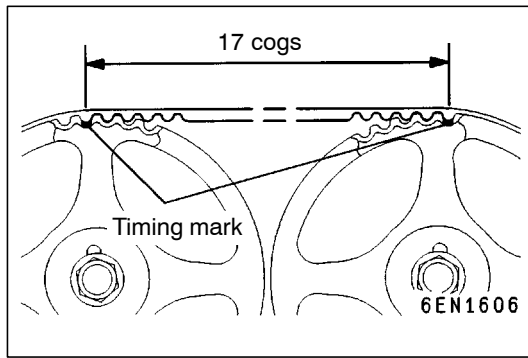

- (9) Check to ensure that the timing marks on the intake camshaft sprocket side are in alignment when the exhaust camshaft sprocket is turned clockwise to align the timing marks.

## NOTE

The timing belt span between the intake and exhaust sprockets will have 17 cogs.

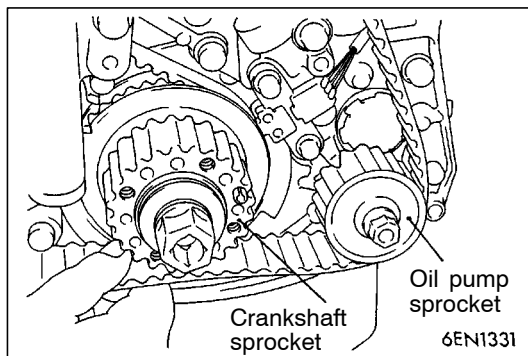

- (10) Fit the timing belt over the idler pulley, oil pump sprocket and crankshaft sprocket in this order.

## NOTE

Be careful that the belt does not become slack.

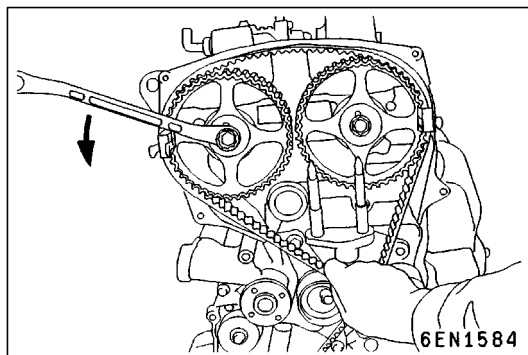

- (11) Fit the timing belt over the tensioner pulley.

## NOTE

When fitting the timing belt over the tensioner pulley, turn the intake side camshaft sprocket a little counterclockwise, as this will facilitate the work.

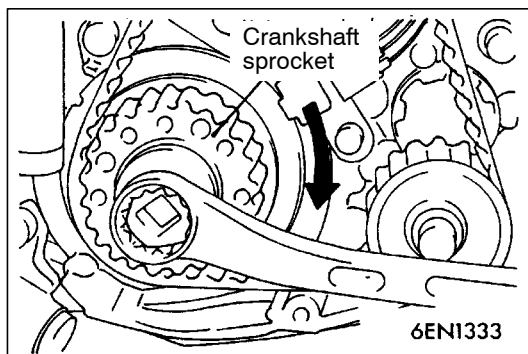

- (12) Turn the crankshaft pulley a little in the illustrated direction to pull up the timing belt at the idler pulley side.

- (13) Check to ensure that the timing marks on the crankshaft sprocket, oil pump sprocket and exhaust camshaft sprocket are all offset one tooth from the corresponding timing marks in the counterclockwise direction.

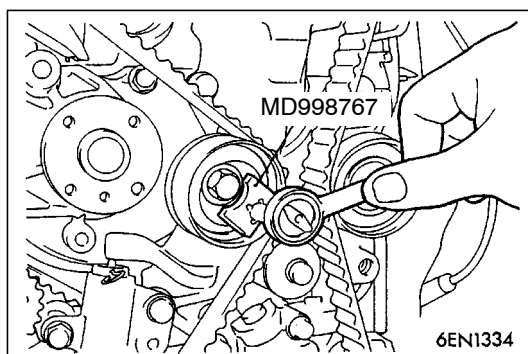

- (14) Using the special tool, turn the tensioner pulley in the illustrated direction to strain the timing belt. Then, secure the tensioner temporarily by tightening the retaining bolt lightly.

## NOTE

There must be no slack in the timing belt between the intake and exhaust camshafts.

- (15) Turn the crankshaft to align the timing mark with the mark for No. 1 cylinder top dead center in the compression stroke.

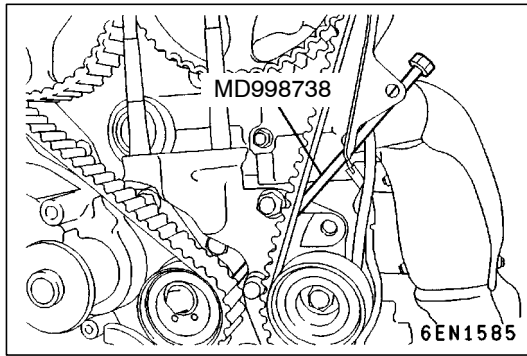

- (16) Set the special tool as shown and screw it in up to the position where the wire inserted in the auto-tensioner when installing it can be moved lightly.

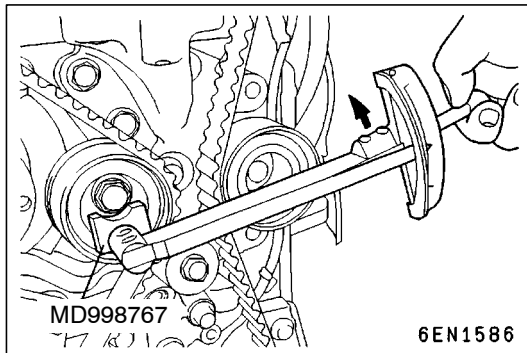

- (17) Loosen the retaining bolt of the tensioner pulley.

#### Caution

- Loosening the retaining bolt can cause the intake and exhaust camshafts to turn, resulting in slackened timing belt. Use care that the timing belt does not come off the sprockets at this time.

- (18) Pull up the slack of the timing belt by turning the tensioner in illustrated direction using the special tool and a torque wrench (0 - 5 Nm).

- (19) From this position, turn back the tensioner until the torque wrench reading becomes 3.5 Nm, then secure it by tightening the retaining bolt.

- (20) Remove the special tool attached in step (16).

- (21) Rotate the crankshaft clockwise 2 turns. Then, leave it intact 15 minutes.

- (22) Check to see that the wire inserted when installing the auto-tensioner can be pulled out lightly. If it can be pulled out lightly, the timing belt is being tensioned properly. If so, remove the wire. In addition, check that the rod protrusion from the auto-tensioner meets the standard value, which is also an indication of properly tensioned timing belt.

**Standard value: 3.8 - 4.5 mm**

- (23) If the wire cannot be removed with a light force, repeat steps (16) through (21) until the proper belt tensioner is obtained.

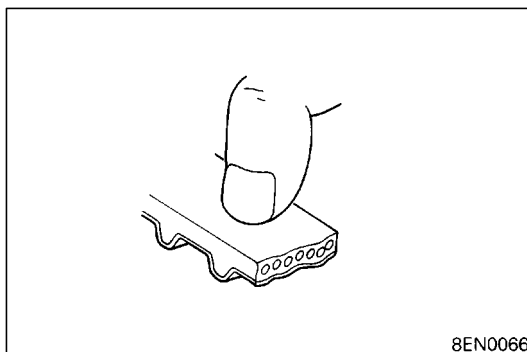
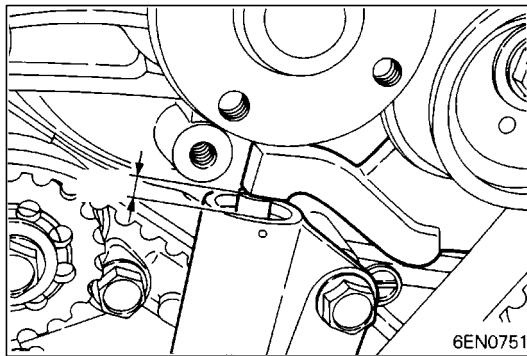

## INSPECTION

### TIMING BELT

Replace belt if any of the following conditions exist.

- (1) Hardening of back rubber.  
Back side is glossy without resilience and leaves no indent when pressed with fingernail.

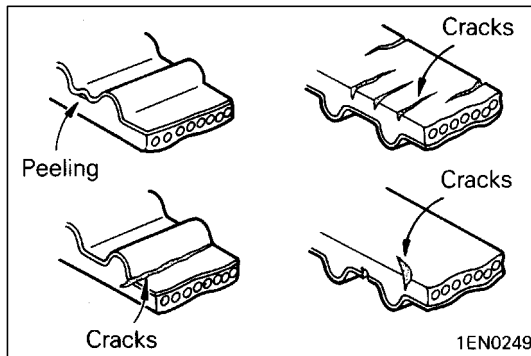

- (2) Cracks on rubber back.
- (3) Cracks or peeling of canvas.
- (4) Cracks on rib root.
- (5) Cracks on belt sides.

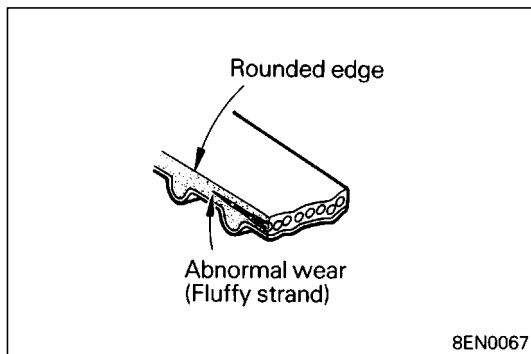

- (6) Abnormal wear of belt sides. The sides are normal if they are sharp as if cut by a knife.

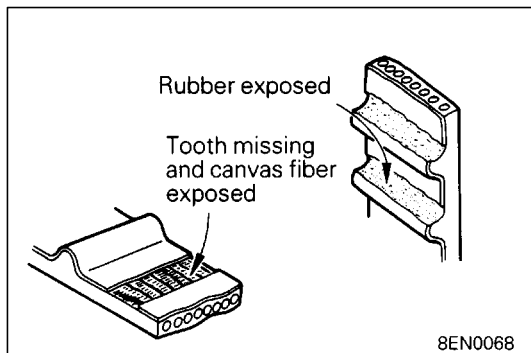

- (7) Abnormal wear on teeth.
- (8) Missing tooth.

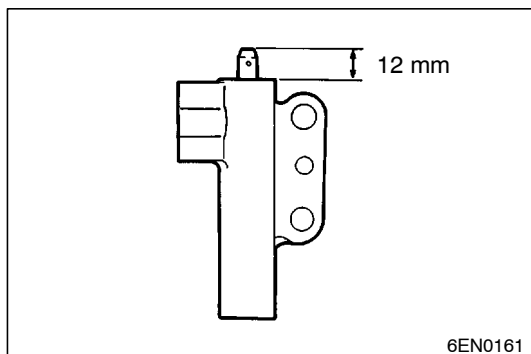

#### AUTO TENSIONER

- (1) Check the auto tensioner for possible leaks and replace as necessary.
- (2) Check the rod end for wear or damage and replace as necessary.
- (3) Measure the rod protrusion. If it is out of specification, replace the auto tensioner.

**Standard value: 12 mm**

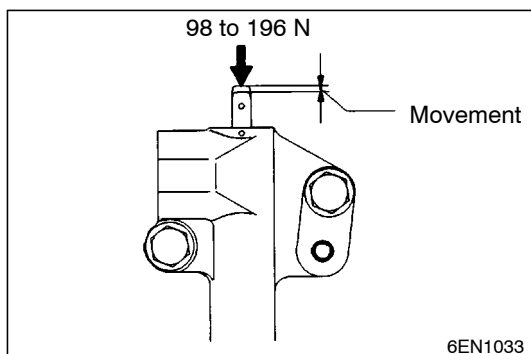

- (4) Press the rod with a force of 98 to 196 N and measure its protrusion.
- (5) If the measured value is 1 mm or more shorter than the value obtained in step (3), replace the auto tensioner.

## 4a. EXHAUST MANIFOLD (GDI)

## REMOVAL AND INSTALLATION

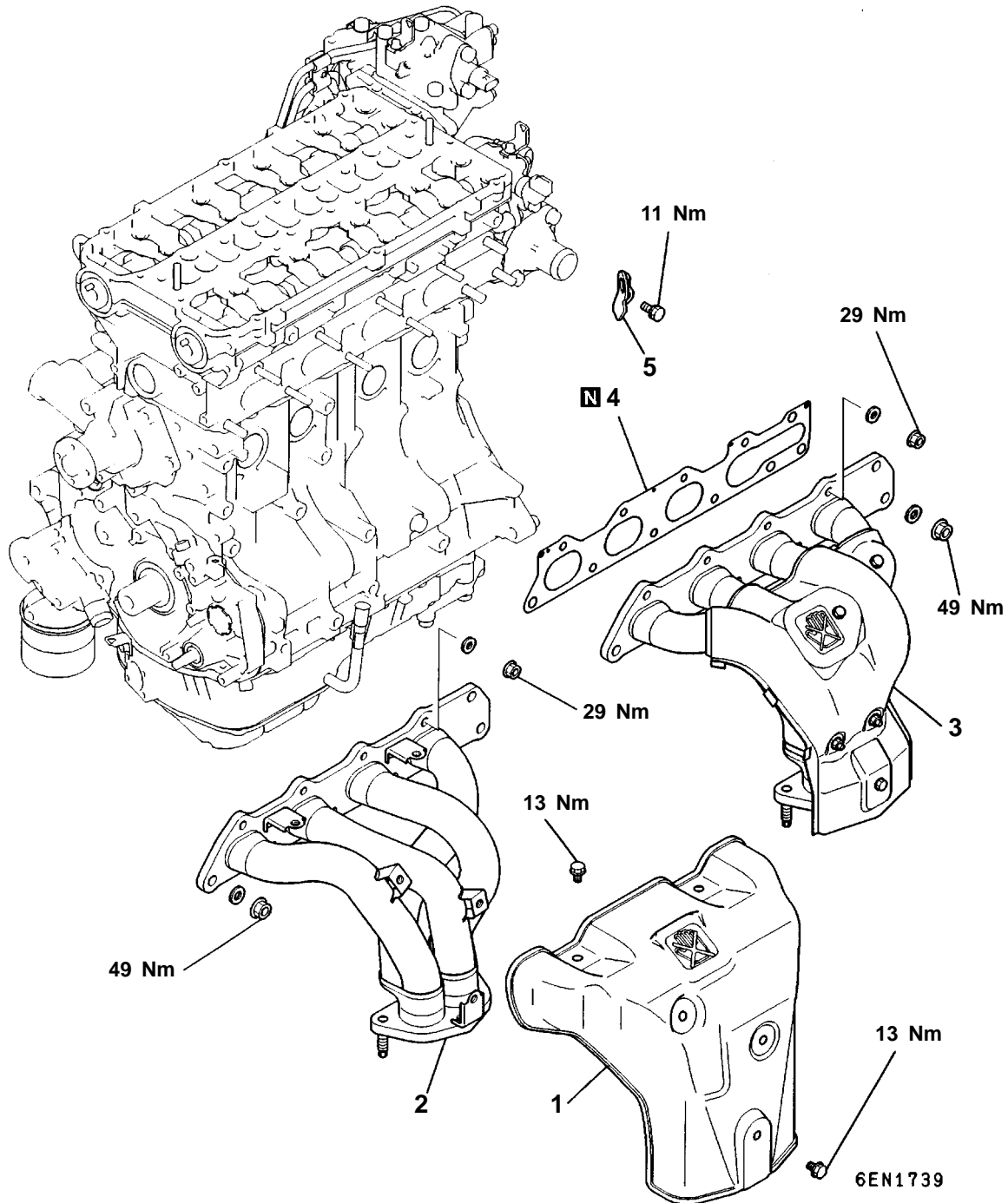
**Removal steps**

1. Exhaust manifold cover (Vehicle for Europe)
2. Exhaust manifold (Vehicle for Europe)
3. Exhaust manifold (Vehicle for Hong Kong)
4. Exhaust manifold gasket
5. Engine hanger



## 5. FUEL AND EMISSION CONTROL PARTS

### REMOVAL AND INSTALLATION <CARBURETOR>

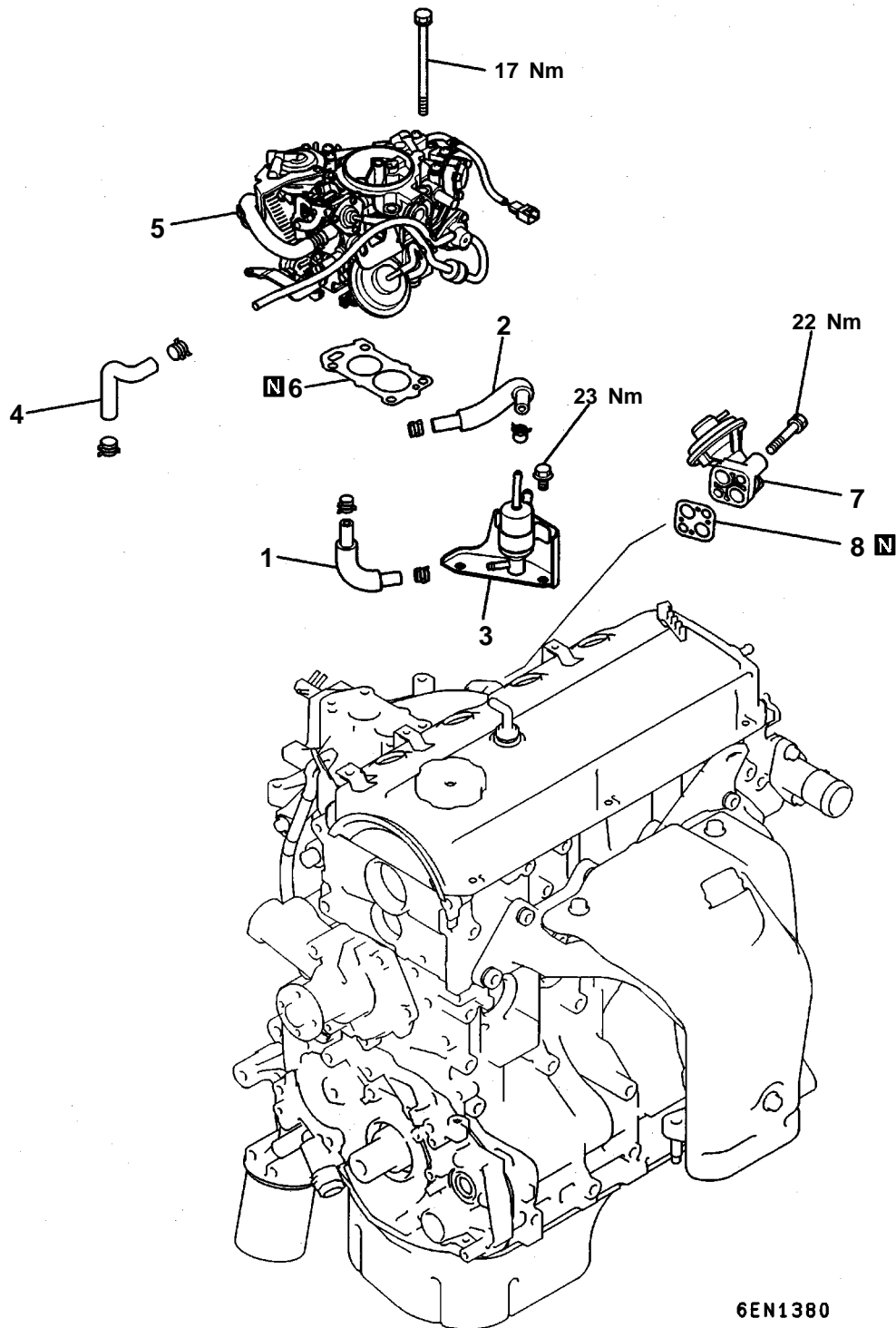

6EN1380

#### Removal steps

1. Fuel hose
2. Fuel hose
3. Fuel vapor separator
4. Water hose
5. Carburetor
6. Gasket
7. EGR valve (For GCC)
8. Gasket (For GCC)

## REMOVAL AND INSTALLATION &lt;MULTIPOINT FUEL INJECTION - GALANT&gt;

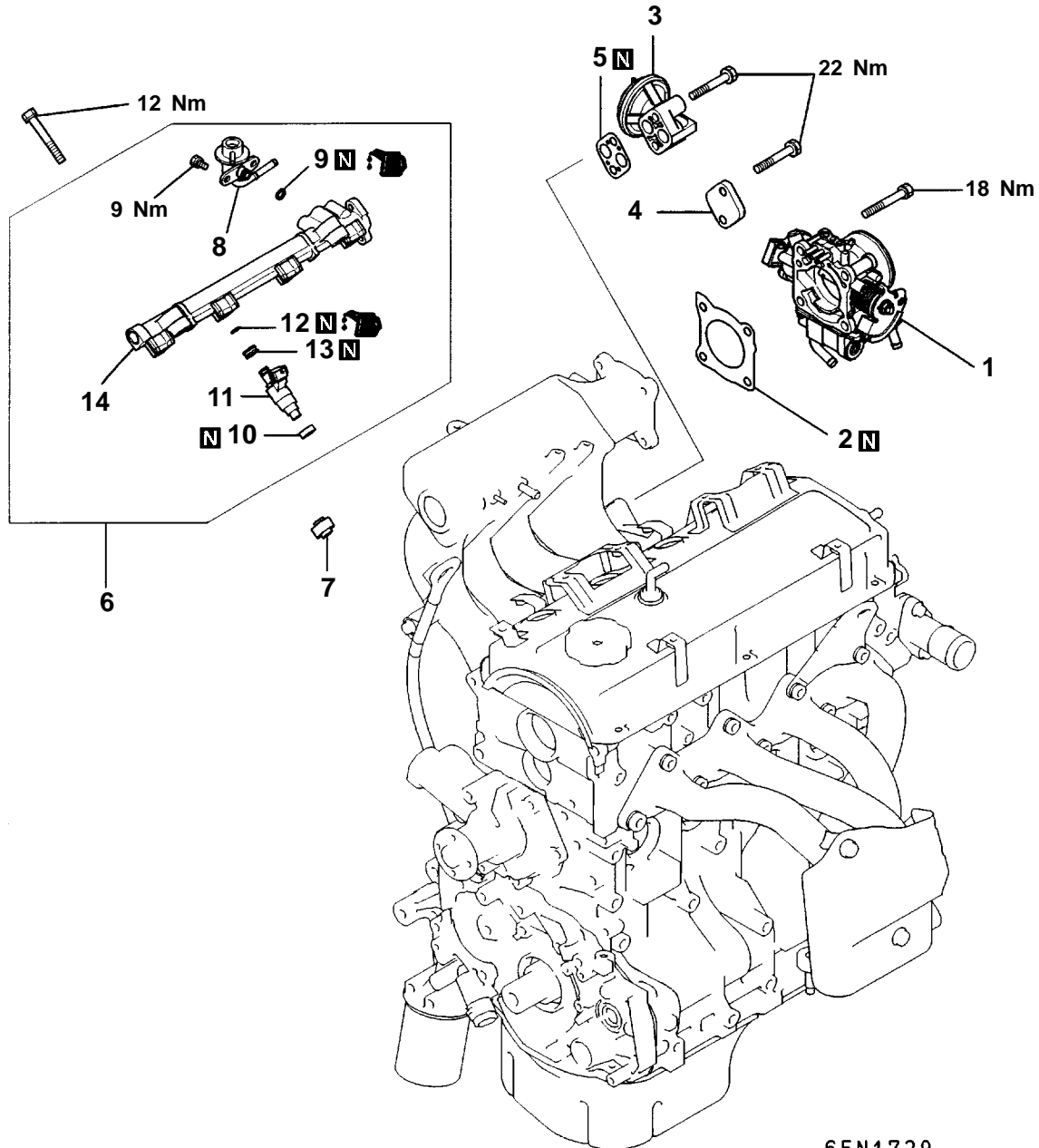

6EN1729

## Removal steps

- |  |  |
|--|--|
| <p>▶C◀</p> <ol style="list-style-type: none"> <li>1. Throttle body</li> <li>2. Throttle body gasket</li> <li>3. EGR valve (With EGR valve)</li> <li>4. Cover (Without EGR valve)</li> <li>5. EGR valve gasket</li> <li>6. Injectors and delivery pipe</li> <li>7. Insulator</li> </ol> | <p>▶B◀</p> <ol style="list-style-type: none"> <li>8. Fuel pressure regulator</li> <li>9. O-ring</li> <li>10. Insulator</li> </ol> <p>▶A◀</p> <ol style="list-style-type: none"> <li>11. Injectors</li> <li>12. O-ring</li> <li>13. Grommet</li> <li>14. Delivery pipe</li> </ol> |
|--|--|

## REMOVAL AND INSTALLATION <MULTIPOINT FUEL INJECTION - SPACE WAGON>

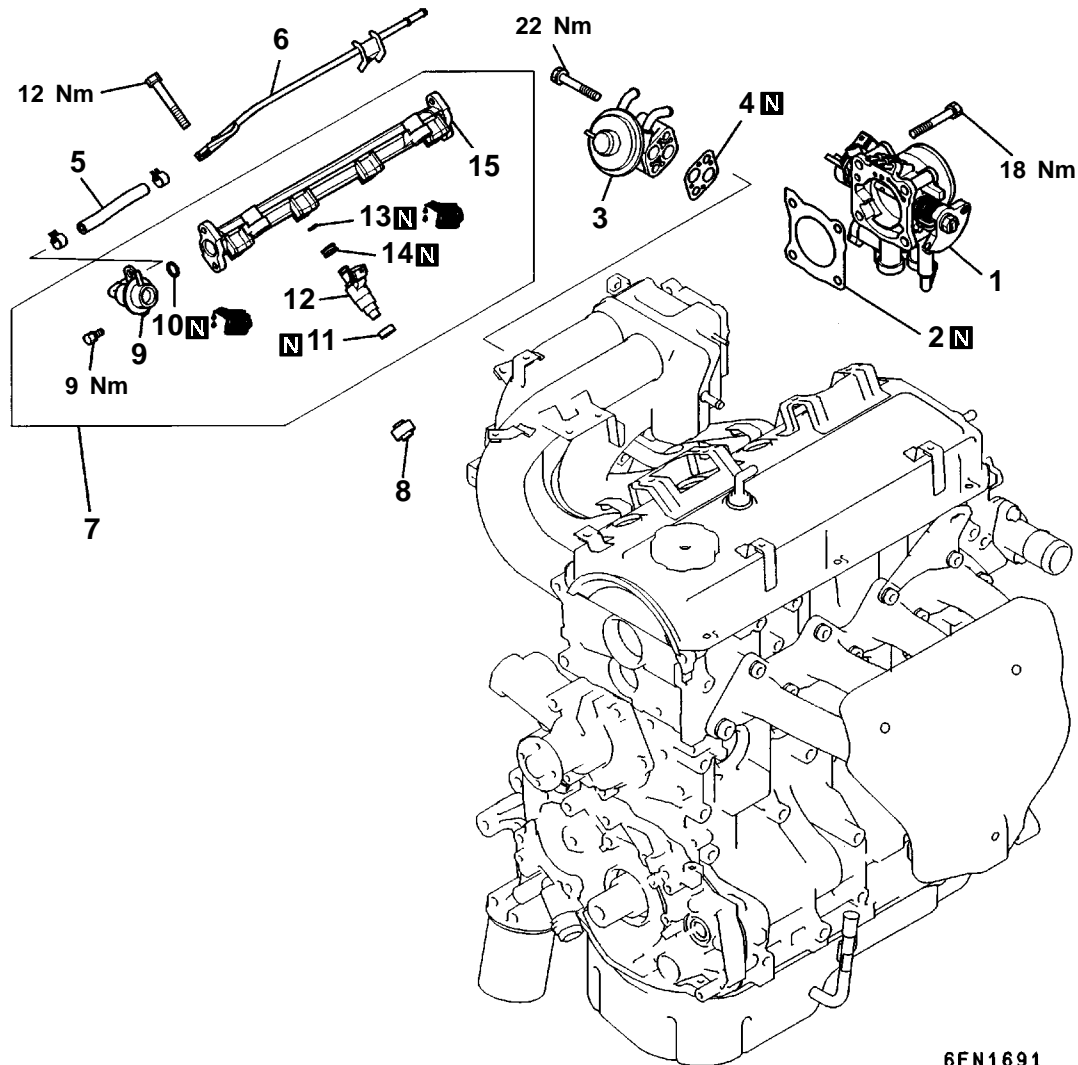

### Removal steps

- |  |   |
|--|---|
| <p>▶C◀</p> <ol style="list-style-type: none"> <li>1. Throttle body</li> <li>2. Throttle body gasket</li> <li>3. EGR valve</li> <li>4. EGR valve gasket</li> <li>5. Fuel hose</li> <li>6. Fuel return pipe</li> <li>7. Injectors and delivery pipe</li> <li>8. Insulator</li> </ol> | <p>▶B◀</p> <ol style="list-style-type: none"> <li>9. Fuel pressure regulator</li> <li>10. O-ring</li> <li>11. Insulator</li> </ol> <p>▶A◀</p> <ol style="list-style-type: none"> <li>12. Injectors</li> <li>13. O-ring</li> <li>14. Grommet</li> <li>15. Delivery pipe</li> </ol> |
|--|---|

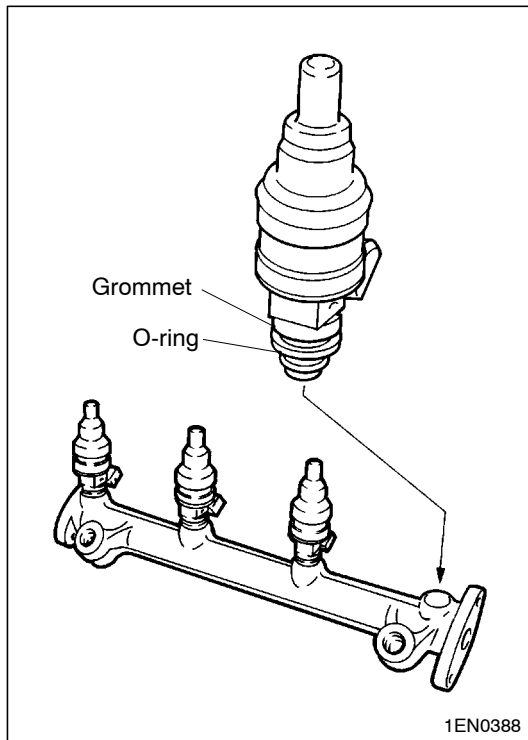

## INSTALLATION SERVICE POINTS

### ►A◄ INJECTORS INSTALLATION

- (1) Before installing an injector, the rubber O-ring must be lubricated with a drop of clean engine oil to aid in installation.
- (2) Install injector top end. Be careful not to damage O-ring during installation.

### ►B◄ FUEL PRESSURE REGULATOR INSTALLATION

- (1) Apply a small amount of new engine oil to the O-ring. Insert the fuel pressure regulator into the delivery pipe being careful not to damage the O-ring.

#### Caution

- **Be sure not to let engine oil get into the delivery pipe.**
- (2) Check that the fuel pressure regulator turns smoothly. If it does not turn smoothly, the O-ring may be trapped. Remove the fuel pressure regulator and check the O-ring for damage, and then re-insert it into the delivery pipe and check once again.

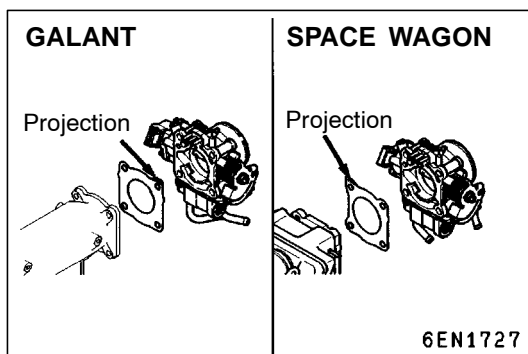

### ►C◄ GASKET INSTALLATION

- (1) Position the projection as shown in the illustration.

5a. FUEL PART (GDI)

REMOVAL AND INSTALLATION (1999 MODEL SPACE WAGON)

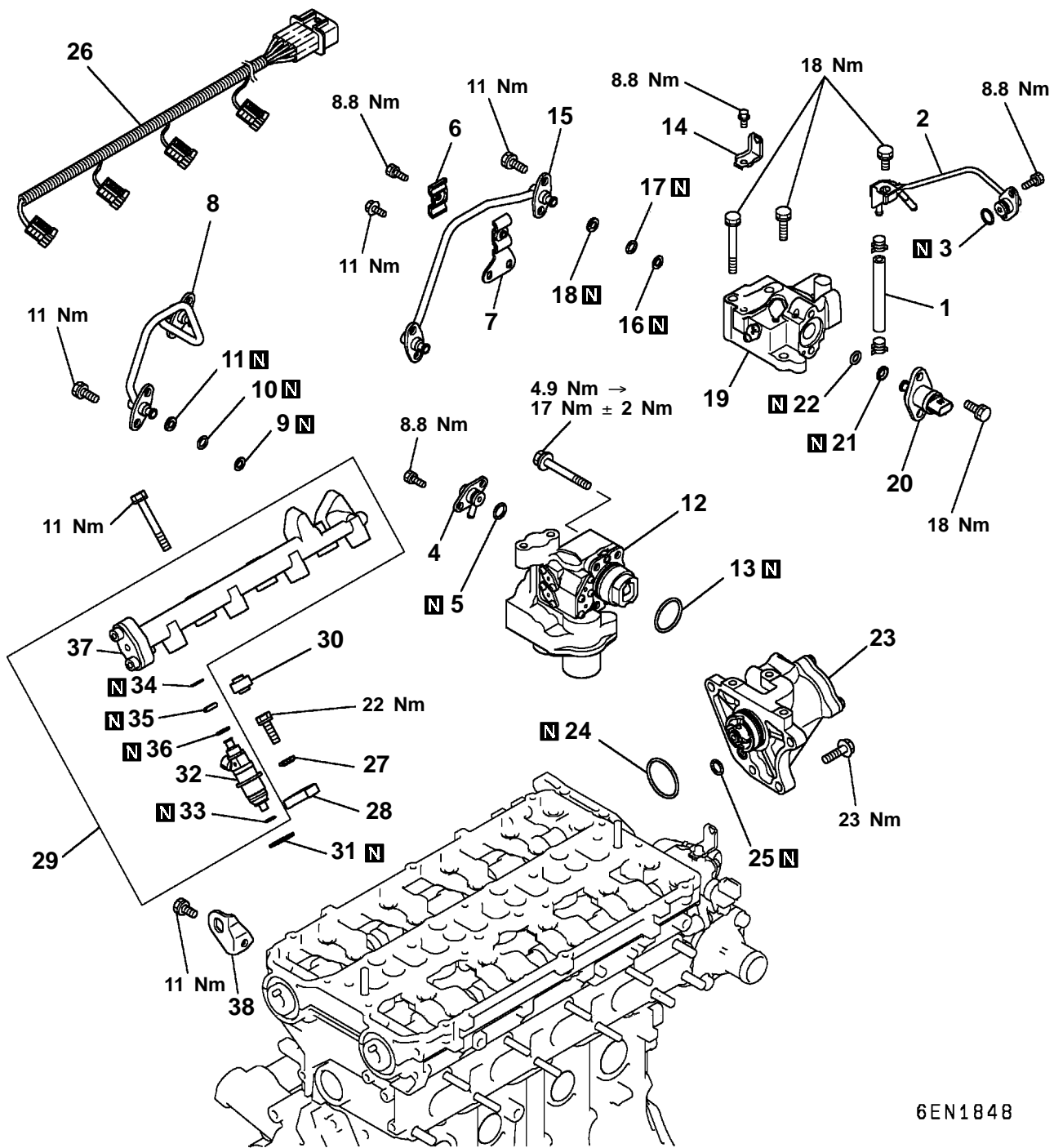

6EN1848

**Removal steps**

1. Fuel hose
2. Fuel low pressure pipe
3. O-ring
4. Fuel pump return nipple
5. O-ring
6. Clamp A
7. Fuel pipe bracket
- ▶F◀ 8. Fuel feed pipe
9. Backup ring
10. O-ring
11. Backup ring
- ▶F◀ 12. Fuel pump
13. O-ring
14. Harness bracket
- ▶E◀ 15. Fuel return pipe
16. Backup ring
17. O-ring
18. Backup ring
- ▶E◀ 19. Fuel high pressure regulator
- ▶D◀ 20. Fuel pressure sensor
21. Backup ring
22. O-ring
- ▶C◀ 23. Pump camshaft case
24. O-ring
25. O-ring
26. Injector harness
27. Washer
28. Injector holder
- ▶B◀ 29. Delivery pipe and injector assembly
30. Insulator
31. Injector washer
32. Injector
- ▶A◀ 33. Corrugated washer
- ▶A◀ 34. Backup ring
- ▶A◀ 35. O-ring
- ▶A◀ 36. Backup ring
37. Delivery pipe
38. Engine hanger

REMOVAL AND INSTALLATION (2000 MODEL SPACE WAGON and GALANT)

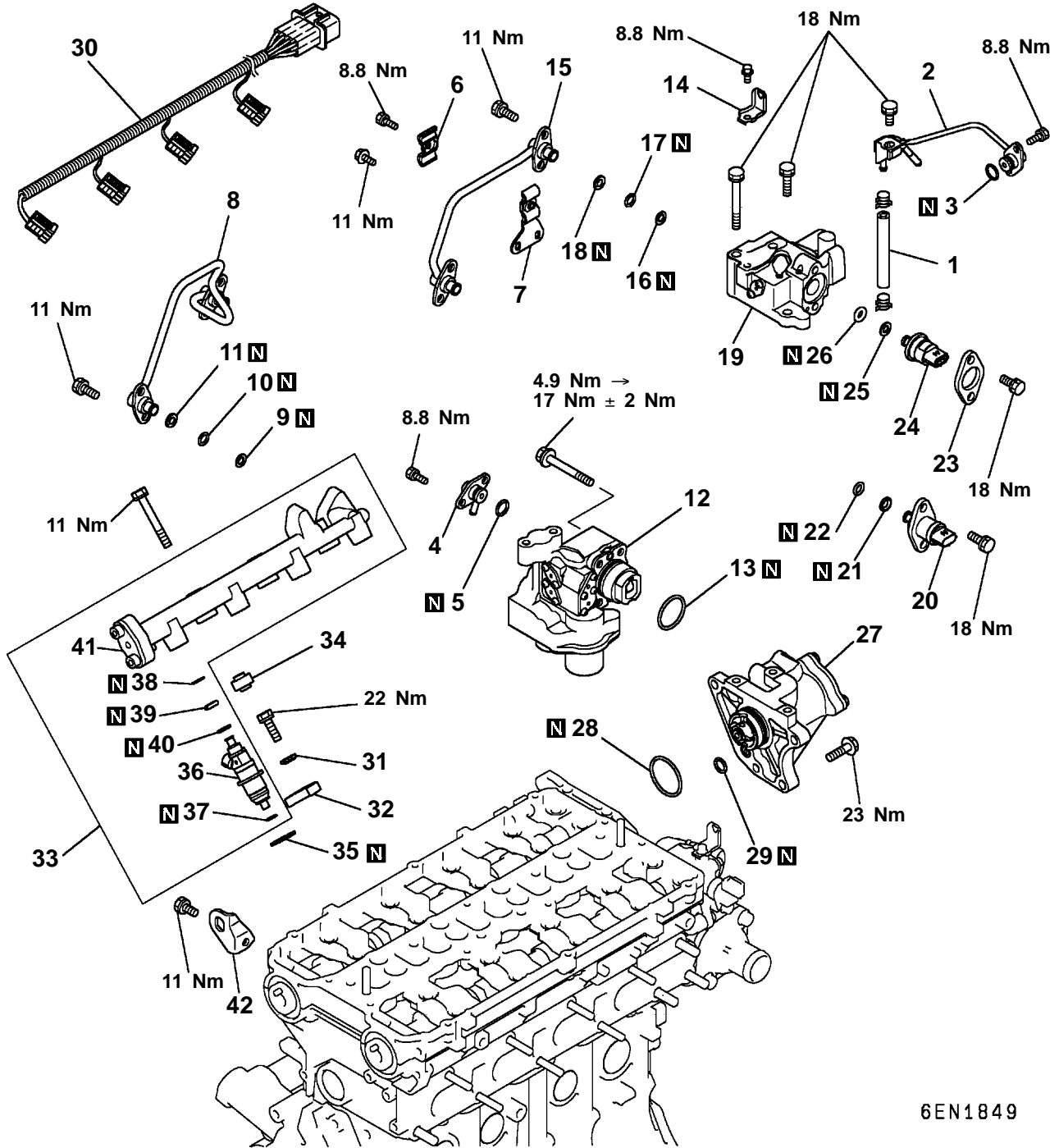

6EN1849

**Removal steps**

1. Fuel hose
2. Fuel low pressure pipe
3. O-ring
4. Fuel pump return nipple
5. O-ring
6. Clamp A
7. Fuel pipe bracket
- ▶F◀ 8. Fuel feed pipe
9. Backup ring
10. O-ring
11. Backup ring
- ▶F◀ 12. Fuel pump
13. O-ring
14. Harness bracket
- ▶E◀ 15. Fuel return pipe
16. Backup ring
17. O-ring
18. Backup ring
- ▶E◀ 19. Fuel high pressure regulator
- ▶D◀ 20. Fuel pressure sensor  
(GALANT and SPACE WAGON for Hong Kong)
21. Backup ring (GALANT and SPACE WAGON for Hong Kong)
22. O-ring (GALANT and SPACE WAGON for Hong Kong)
23. Flange  
(SPACE WAGON for Europe)
- ▶D◀ 24. Fuel pressure sensor  
(SPACE WAGON for Europe)
25. Backup ring  
(SPACE WAGON for Europe)
26. O-ring  
(SPACE WAGON for Europe)
- ▶C◀ 27. Pump camshaft case
28. O-ring
29. O-ring
30. Injector harness
31. Washer
32. Injector holder
- ▶B◀ 33. Delivery pipe and injector assembly
34. Insulator
35. Injector washer
36. Injector
- ▶A◀ 37. Corrugated washer
- ▶A◀ 38. Backup ring
- ▶A◀ 39. O-ring
- ▶A◀ 40. Backup ring
41. Delivery pipe
42. Engine hanger



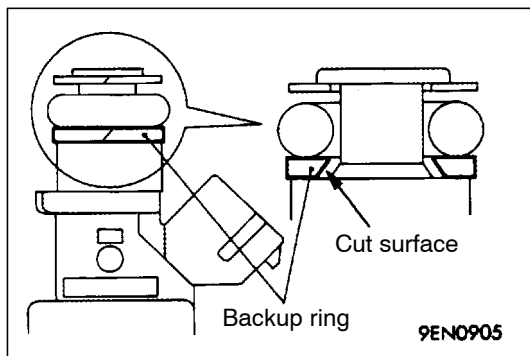

## INSTALLATION SERVICE POINTS

### ▶A◀ BACKUP RING / CORRUGATED WASHER INSTALLATION

- (1) Attach the backup ring and O-ring to the injector. The thicker backup ring must be so installed that the inside cut surface is directed as shown in the illustration.

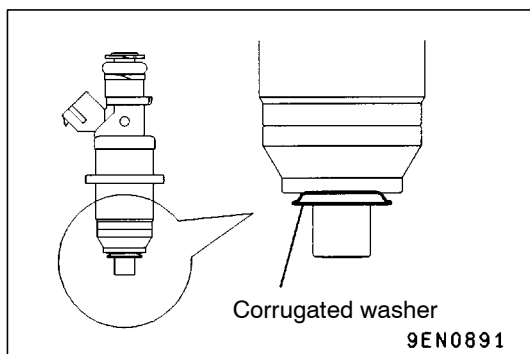

- (2) Coat the corrugated washer with white vaseline and install it to the injector as shown.

#### Caution

- Always replace the corrugated washer with new one. Reused corrugated washer can cause fuel or gas leaks.

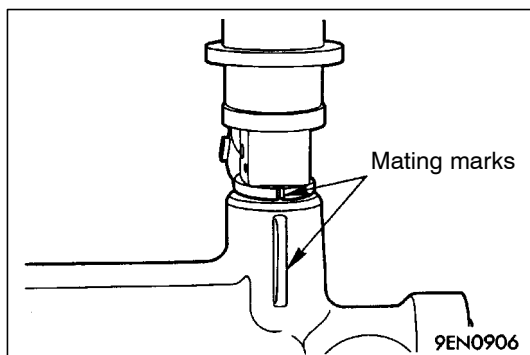

### ▶B◀ DELIVERY PIPE AND INJECTOR ASSEMBLY INSTALLATION

- (1) Lubricate O-ring in the injector with spindle oil gasoline.
- (2) Insert the injector straight into the injector mounting hole in the delivery pipe.
- (3) Turn the injector clockwise and counterclockwise. If it does not rotate smoothly, remove it to check for damaged O-ring. Damaged O-ring must be replaced with a new one. Reinstall the injector and check for smooth rotation again.
- (4) Align the mating mark on the injector with that on the delivery pipe.
- (5) Install the injector gaskets and insulators on the cylinder head. The insulator can drop off easily. Apply vaseline to it before installation so that it may be held in position.
- (6) Install the delivery pipe and injector assembly onto the cylinder head, tighten the fasteners temporarily.
- (7) Install the injector holders and the washers to the assembly and tighten the fasteners to the specified torque.

#### Caution

- Strictly observe the specified torque.

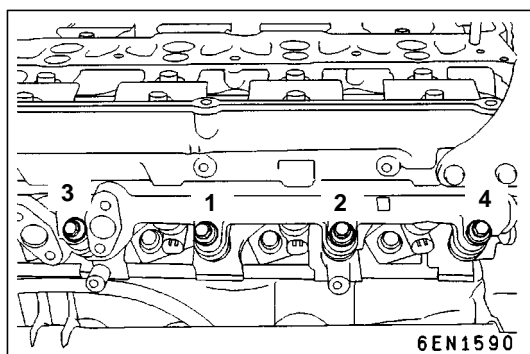
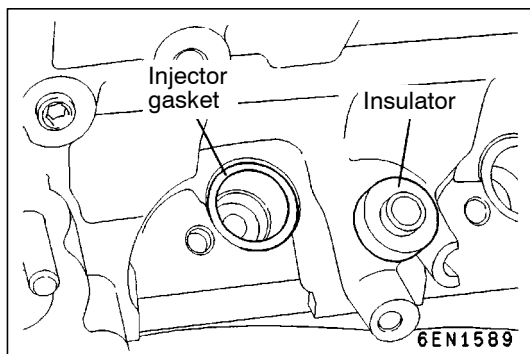

- (8) Tighten the fasteners of the delivery pipe and injector assembly to the specified torque in the order given in the illustration.

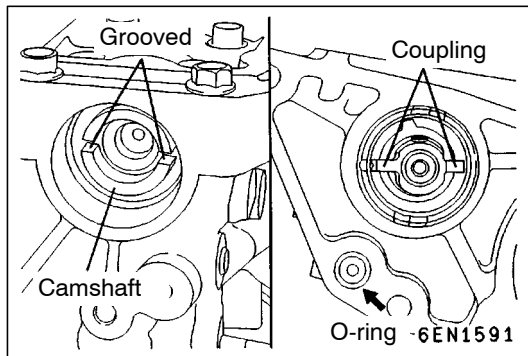

### ►C◄ PUMP CAMSHAFT CASE INSTALLATION

- (1) Lubricate the O-ring (smaller one for oil passage) with vaseline and install it in the pump camshaft case.
- (2) Apply small amount of engine oil to the O-ring (larger one) in the case.
- (3) Install the pump camshaft case onto the cylinder head while aligning its coupling with the groove in the camshaft end.

#### NOTE

The key of the coupling and the groove in the camshaft end are both arranged offset with respect to the camshaft center.

- (4) Tighten the pump camshaft case mounting bolts to the specified torque.

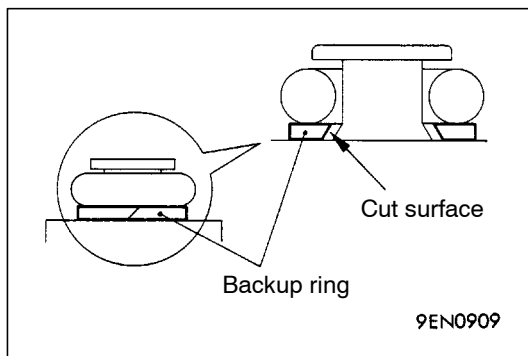

### ►D◄ FUEL PRESSURE SENSOR INSTALLATION

- (1) Install the backup ring to the fuel pressure sensor with its inside cut surface in the illustrated direction.
- (2) Install the fuel pressure sensor straight into the fuel pressure regulator with labeled surface upward.
- (3) Tighten the fuel pressure sensor mounting bolt to the specified torque.

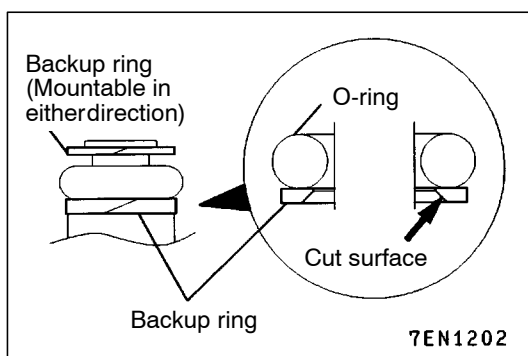

### ►E◄ FUEL HIGH PRESSURE REGULATOR / FUEL RETURN PIPE INSTALLATION

- (1) Install the fuel high pressure regulator on the pump camshaft case and tighten the 3 bolts lightly (with somewhat larger torque than finger tight). Tightening to the specification is to be carried out in the step described in ►F◄.
- (2) Fit the backup rings and the O-ring on both ends of the fuel return pipe. Note that the larger backup ring must be installed with the inside cut surface in the direction shown in the illustration.
- (3) Lubricate the O-rings on both ends of the pipe with spindle oil or gasoline.
- (4) Insert the fuel return pipe ends straight in the respective mounting holes of the pressure regulator and the delivery pipe. Be sure to insert the pipe fully to the stop using care not to twist it.
- (5) Tighten the bolts at both ends of the pipe to the specified torque.

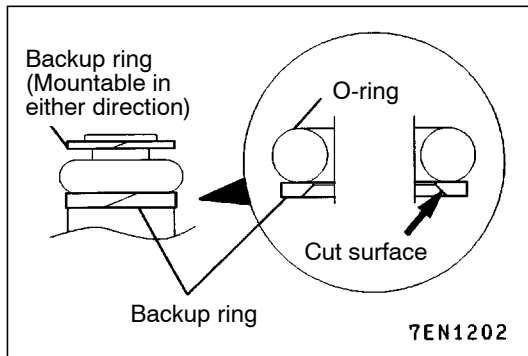

### ►F◄ FUEL PUMP / FUEL FEED PIPE INSTALLATION

- (1) Insert the fuel pump into the mounting hole in the pump camshaft case, and secure it temporarily with 4 bolts (tighten somewhat with a larger torque than finger tight).
- (2) Fit the backup rings and the O-ring on both ends of the feed pipe. Note that the larger backup ring must be installed with the inside cut surface in the direction shown in the illustration.
- (3) Lubricate the O-rings on both ends of the pipe with spindle oil or gasoline.
- (4) Insert the fuel feed pipe ends straight in the respective mounting holes of the fuel and the delivery pipe. Be sure to insert the pipe fully to the stop using care not to twist it.
- (5) Tighten the bolts at ends of the pipe to the specified torque.
- (6) Tighten the mounting bolts of the fuel pressure regulator to the specified torque.

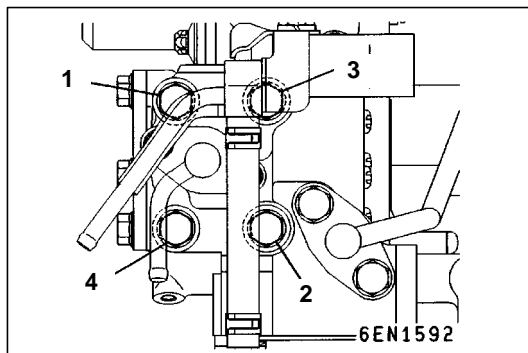

- (7) Using a torque wrench having the minimum scale of 0.5 Nm, tighten the fuel pump mounting bolts in the following order.
  - 1) Tighten the bolts to 4.9 Nm in the order given in the illustration.
  - 2) Tighten the bolts to 17 Nm in the order given in the illustration. The torque variation among 4 bolts must be within 2 Nm.

#### Caution

- **Strictly observe the specified tightening torque. Deviation from the specification can cause problems such as leakage or the like.**

- (8) Clamp the fuel return pipe and feed pipe using the fuel pipe bracket and clamp A, and tighten them lightly.
- (9) Secure the fuel pipe bracket to the cam cap temporarily.
- (10) Tighten the bolts which are securing the pipes temporarily to the specified torque.
- (11) Tighten the bolts on the beam cam shaft side which have been temporarily tightened to the specified torque.

## 6. WATER PUMP AND INTAKE MANIFOLD

### REMOVAL AND INSTALLATION <CARBURETOR>

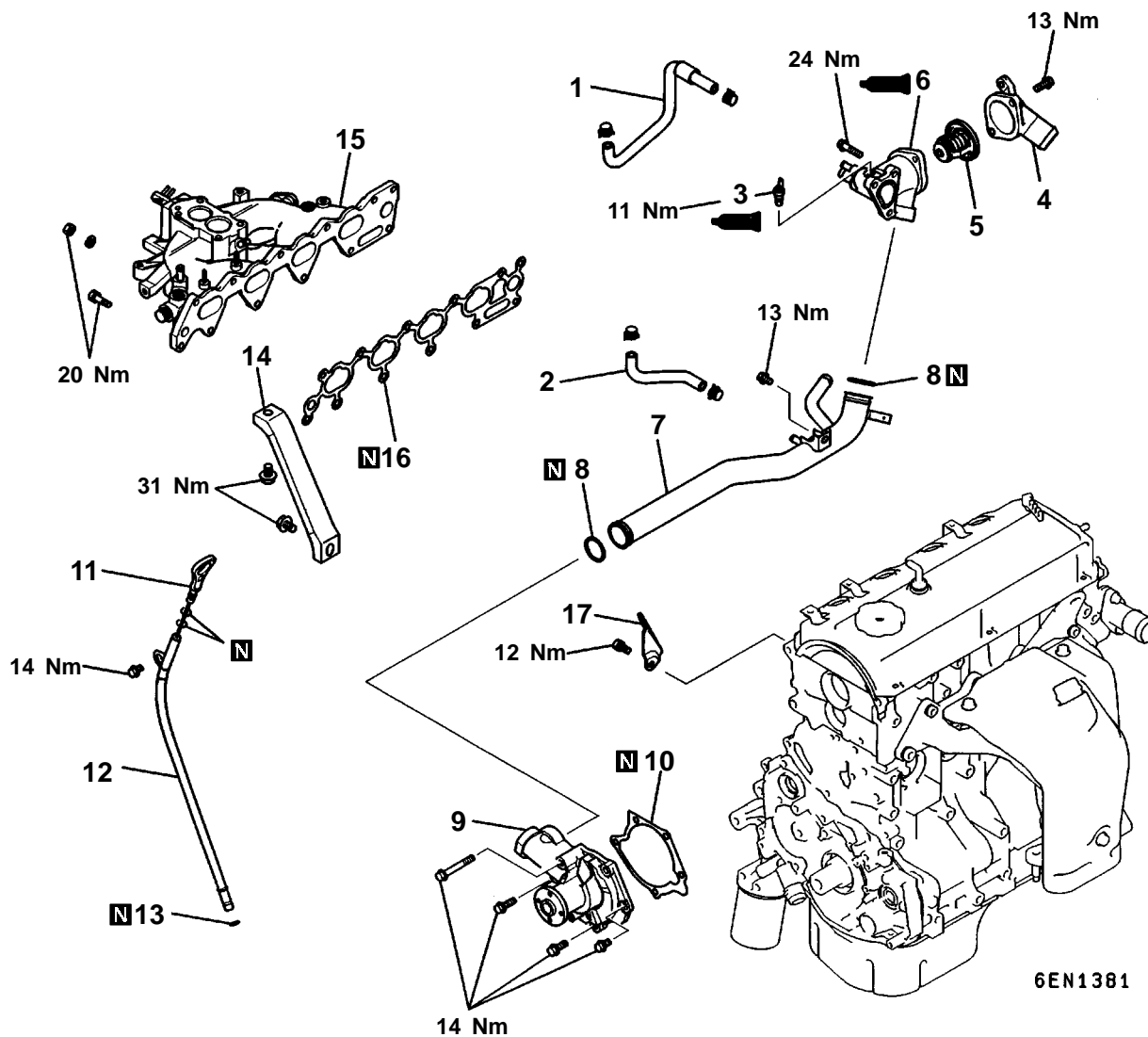

#### Removal steps

- 1. Water hose
- 2. Water hose
- ▶C◀ 3. Engine coolant temperature gauge unit
- 4. Water inlet fitting
- 5. Thermostat
- ▶B◀ 6. Thermostat housing
- ▶A◀ 7. Water inlet pipe
- ▶A◀ 8. O-ring

- 9. Water pump
- 10. Water pump gasket
- 11. Oil level gauge
- 12. Oil level gauge guide
- 13. O-ring
- 14. Intake manifold stay
- 15. Intake manifold
- 16. Intake manifold gasket
- 17. Engine hanger

## REMOVAL AND INSTALLATION &lt;MULTIPOINT FUEL INJECTION - GALANT&gt;

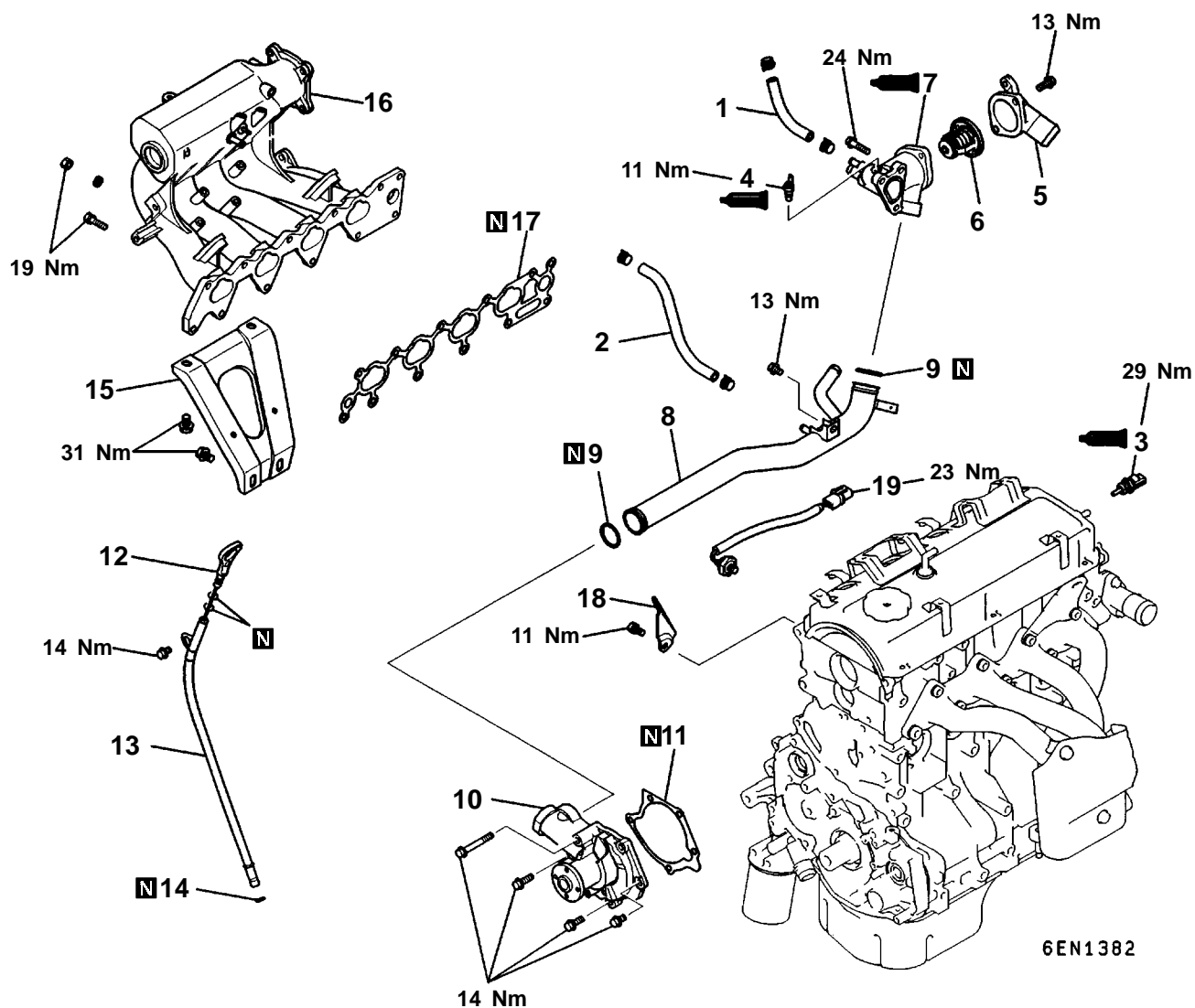
**Removal steps**

1. Water hose
2. Water hose
- D**  
**C** 3. Engine coolant temperature sensor
4. Engine coolant temperature gauge unit
5. Water inlet fitting
6. Thermostat
- B**  
**A**  
**A** 7. Thermostat housing
8. Water inlet pipe
9. O-ring

10. Water pump
11. Water pump gasket
12. Oil level gauge
13. Oil level gauge guide
14. O-ring
15. Intake manifold stay
16. Intake manifold
17. Intake manifold gasket
18. Engine hanger
19. Detonation sensor

**REMOVAL AND INSTALLATION**  
**<MULTIPOINT FUEL INJECTION - SPACE WAGON>**

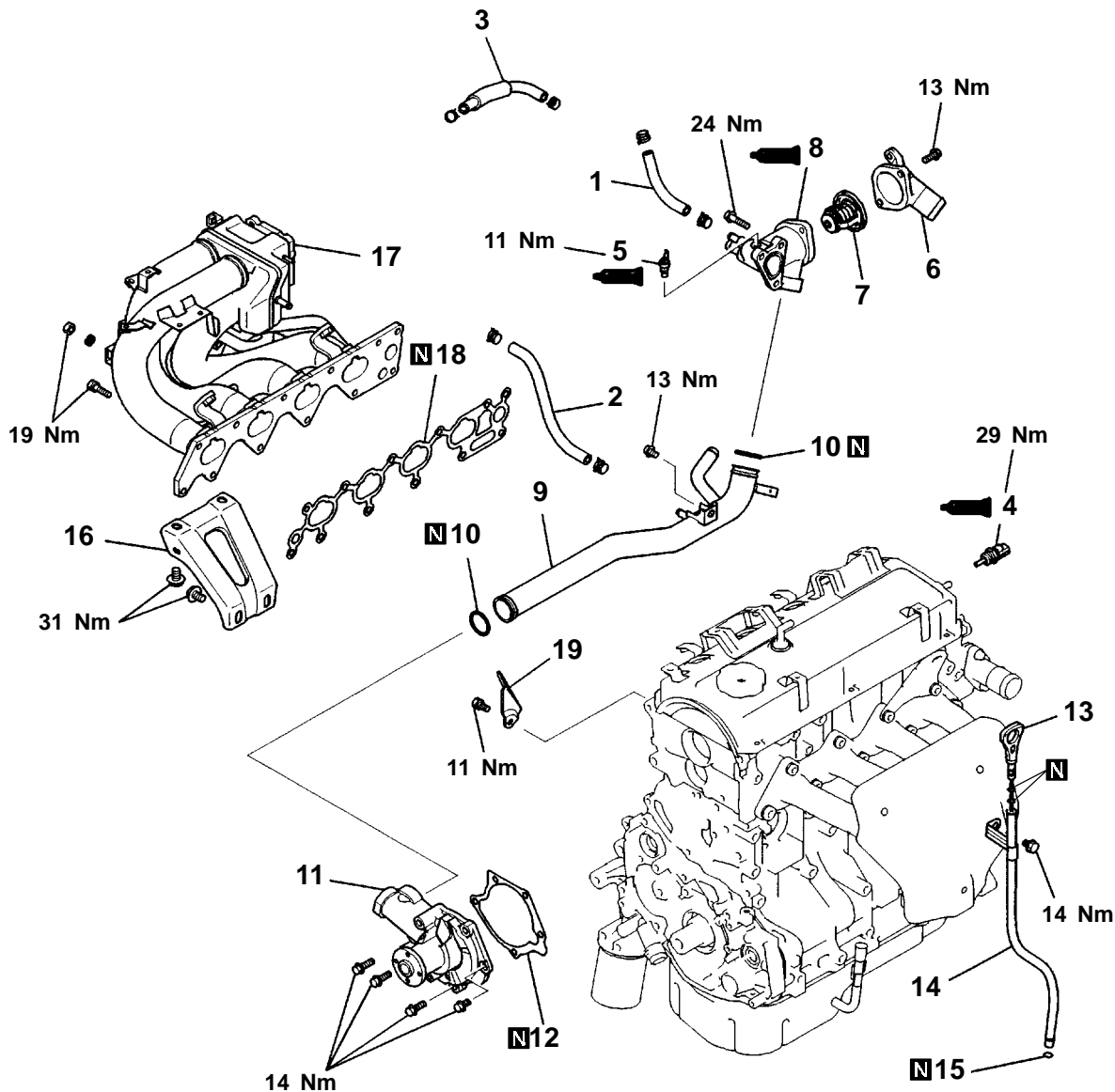

6EN1693

**Removal steps**

- |     |  |     |                            |
|-----|--|-----|----------------------------|
|     | 1. Water hose                            |     | 10. O-ring                 |
|     | 2. Water hose                            |     | 11. Water pump             |
|     | 3. Water hose                            |     | 12. Water pump gasket      |
| ▶D▶ | 4. Engine coolant temperature sensor     | ▶A▶ | 13. Oil level gauge        |
| ▶C▶ | 5. Engine coolant temperature gauge unit |     | 14. Oil level gauge guide  |
|     | 6. Water inlet fitting                   |     | 15. O-ring                 |
|     | 7. Thermostat                            |     | 16. Intake manifold stay   |
| ▶B▶ | 8. Thermostat housing                    |     | 17. Intake manifold        |
| ▶A▶ | 9. Water inlet pipe                      |     | 18. Intake manifold gasket |
|     |  |     | 19. Engine hanger          |

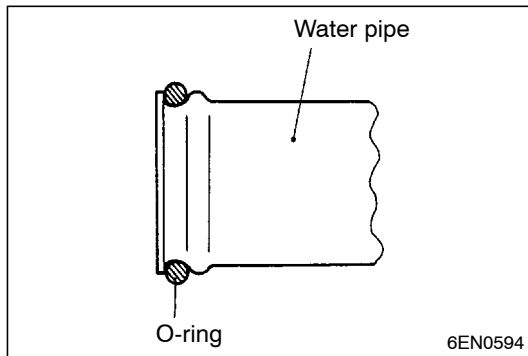

## INSTALLATION SERVICE POINTS

### ▶A◀ WATER PIPE / O-RING INSTALLATION

(1) Wet the O-ring (with water) to facilitate assembly.

#### Caution

- Keep the O-ring free of oil or grease.

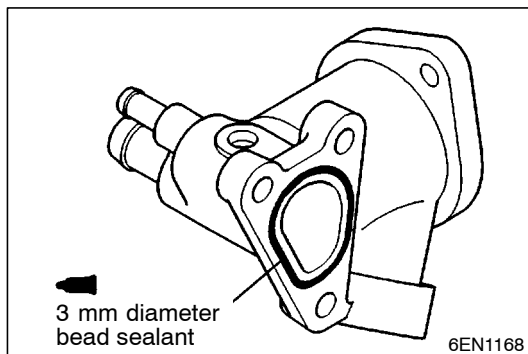

### ▶B◀ SEALANT APPLICATION TO THERMOSTAT HOUSING

#### Specified sealant:

Mitsubishi Genuine Part No. MD970389 or equivalent

#### NOTE

- (1) Be sure to install the housing quickly while the sealant is wet (within 15 minutes).
- (2) After installation, keep the sealed area away from the oil and coolant for approx. 1 hour.

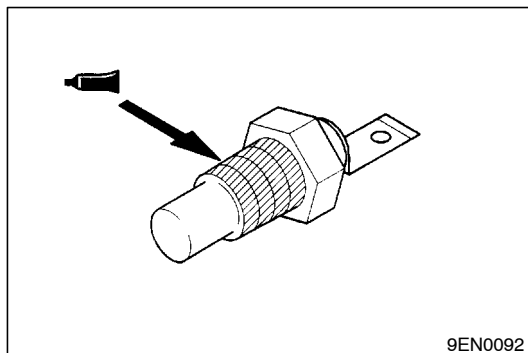

### ▶C◀ SEALANT APPLICATION TO ENGINE COOLANT TEMPERATURE GAUGE UNIT

Specified sealant: 3M ATD Part No. 8660 or equivalent

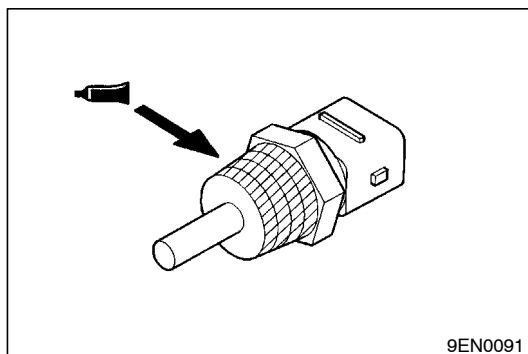

### ▶D◀ SEALANT APPLICATION TO ENGINE COOLANT TEMPERATURE SENSOR

#### Specified sealant:

3M Nut Locking Part No. 4171 or equivalent

# 6a. WATER PUMP AND WATER HOSE (GDI)

## REMOVAL AND INSTALLATION

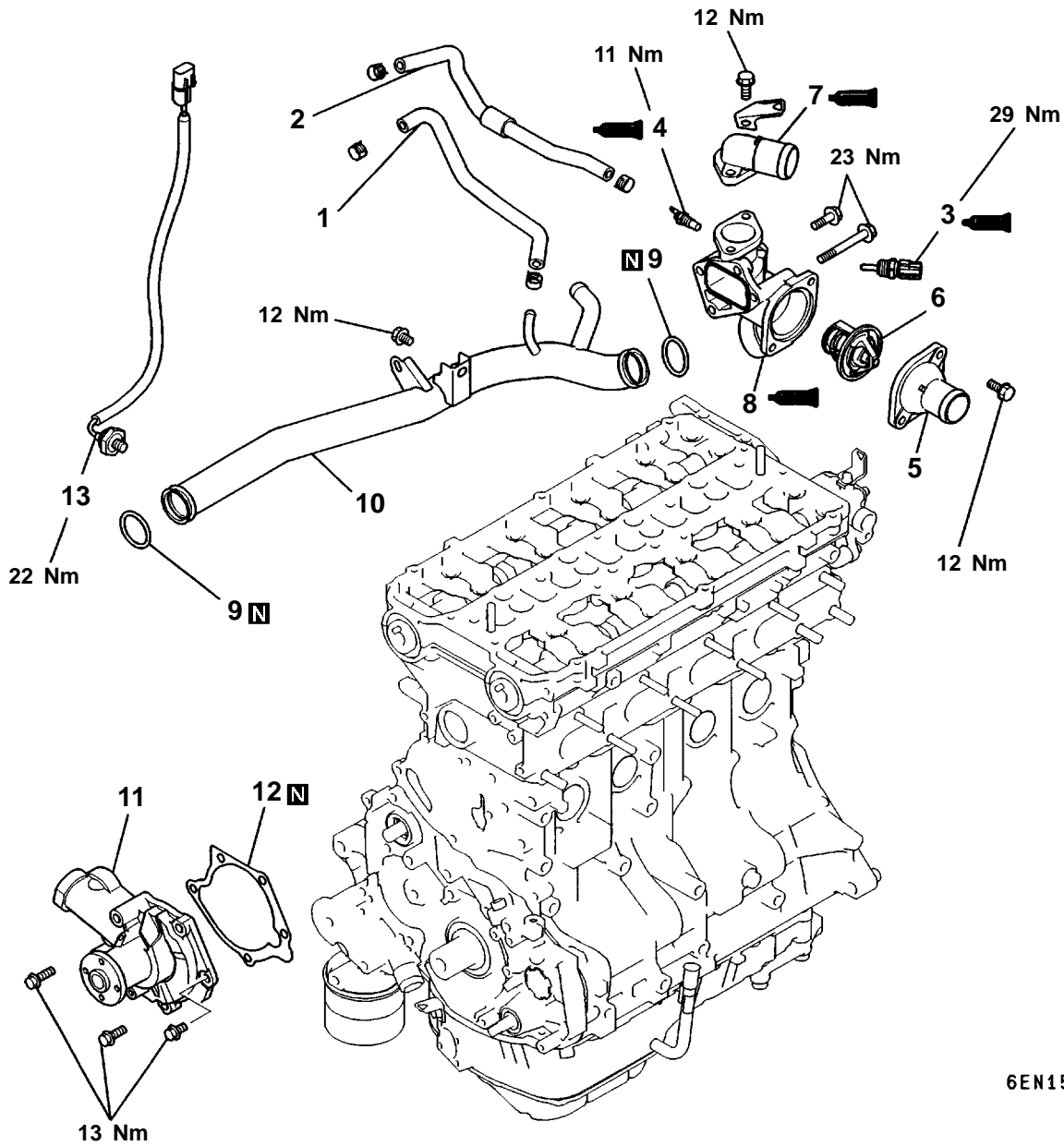

6EN1593

### Removal steps

- ▶E◀ 1. Water hose
- ▶E◀ 2. Water hose
- ▶D◀ 3. Engine coolant temperature sensor
- ▶D◀ 4. Engine coolant temperature gauge unit
- 5. Water inlet fitting
- 6. Thermostat

- ▶C◀ 7. Water outlet fitting
- ▶B◀ 8. Thermostat housing
- ▶A◀ 9. O-ring
- ▶A◀ 10. Water inlet pipe
- 11. Water pump
- 12. Gasket
- 13. Knock sensor



## INSTALLATION SERVICE POINTS

### ▶A◀ O-RING / WATER INLET PIPE INSTALLATION

- (1) Replace the O-ring of the water inlet pipe, and then apply water to the O-ring to make installation easy.

#### Caution

- Never apply any oil or grease to the O-ring.
- Secure the water pipe after the thermostat case has been reinstalled.

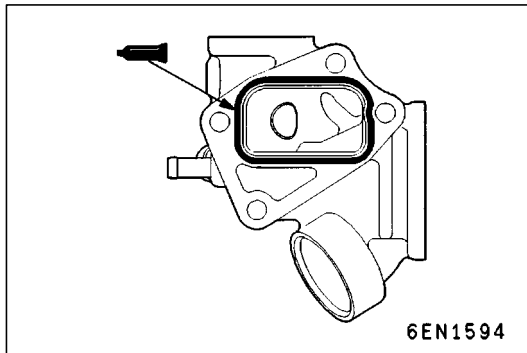

### ▶B◀ THERMOSTAT CASE INSTALLATION

- (1) Apply 3 mm diameter of Form-In-Place Gasket (FIPG) to the location shown in the illustration.

#### Specified sealant:

Mitsubishi Genuine Part No. MD970389 or equivalent

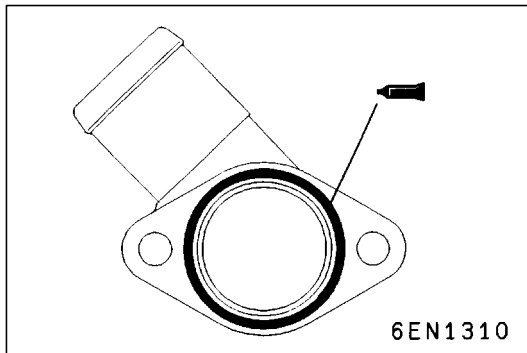

### ▶C◀ WATER OUTLET FITTING INSTALLATION

- (1) Apply 3 mm diameter of Form-In-Place Gasket (FIPG) to the location shown in the illustration.

#### Specified sealant:

Mitsubishi Genuine Part No. MD970389 or equivalent

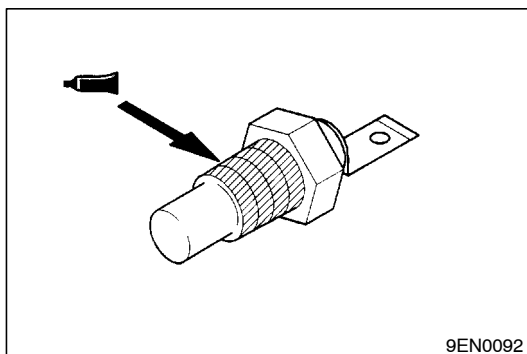

### ▶D◀ ENGINE COOLANT TEMPERATURE GAUGE UNIT INSTALLATION

- (1) Apply the specified sealant to the threads.

#### Specified sealant:

3M ATD Part No. 8660 or equivalent

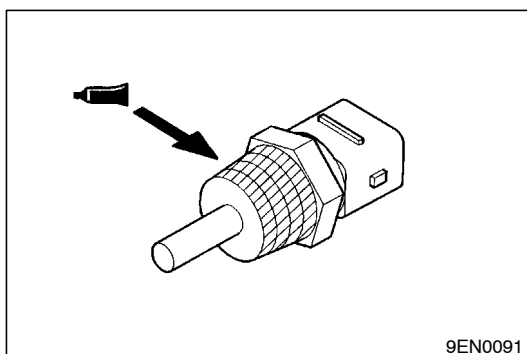

### ▶E◀ ENGINE COOLANT TEMPERATURE SENSOR INSTALLATION

- (1) When reusing the sensor, apply the specified sealant to the threads.

#### Specified sealant:

3M Nut Locking Part No. 4171 or equivalent

## 7. EXHAUST MANIFOLD

### REMOVAL AND INSTALLATION (GALANT)

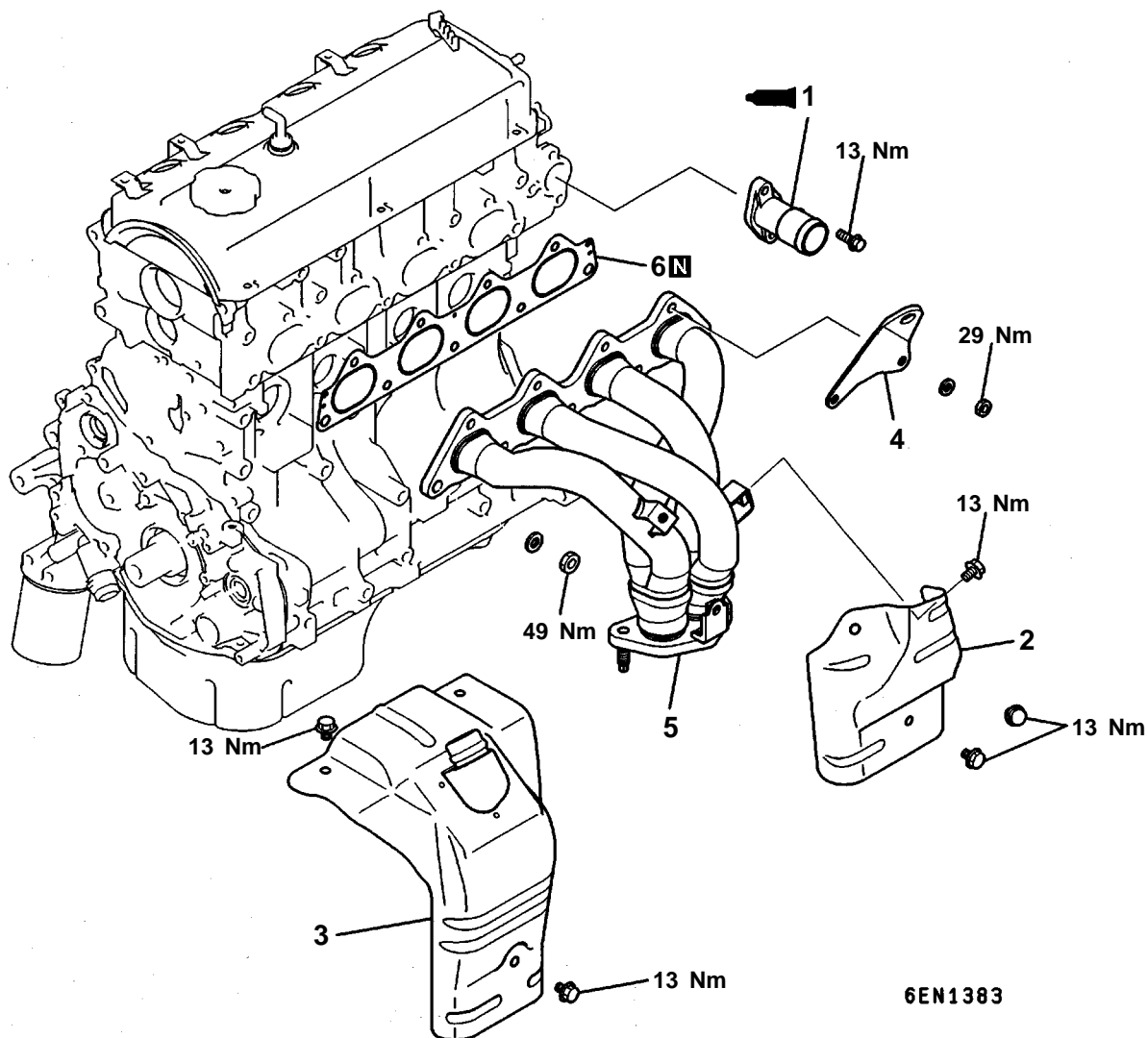

#### Removal steps



1. Water outlet fitting
2. Heat protector  
(Multipoint fuel injection)
3. Exhaust manifold cover  
(Carburetor)
4. Engine hanger
5. Exhaust manifold
6. Exhaust manifold gasket

## REMOVAL AND INSTALLATION (SPACE WAGON)

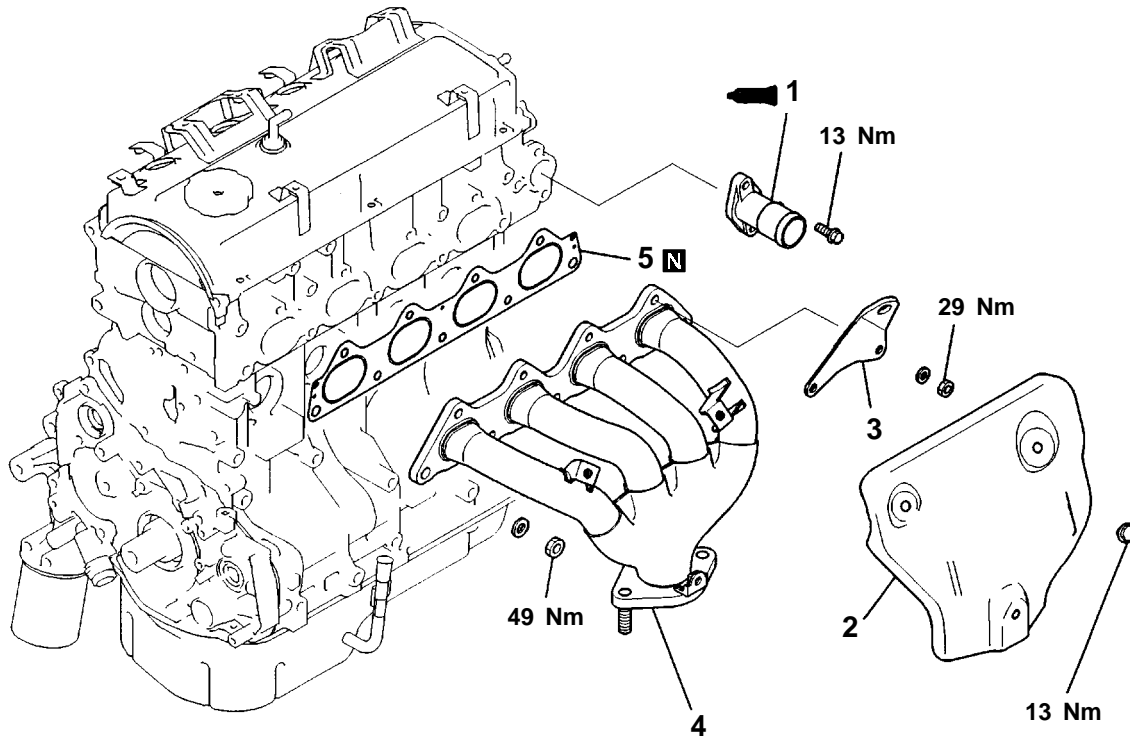

6EN1694

## Removal steps

- ▶A◀
1. Water outlet fitting
  2. Exhaust manifold cover
  3. Engine hanger
  4. Exhaust manifold
  5. Exhaust manifold gasket

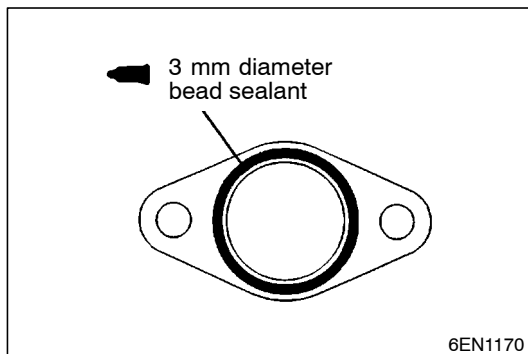

6EN1170

## INSTALLATION SERVICE POINTS

## ▶A◀ SEALANT APPLICATION TO WATER OUTLET FITTING

## Specified sealant:

Mitsubishi Genuine Part No. MD970389 or equivalent

## NOTE

- (1) Be sure to install the water outlet fitting quickly while the sealant is wet (within 15 minutes).
- (2) After installation, keep the sealed area away from the oil and coolant for approx. 1 hour.

# 8. ROCKER ARMS AND CAMSHAFT

## REMOVAL AND INSTALLATION

 Apply engine oil to all moving parts before installation.

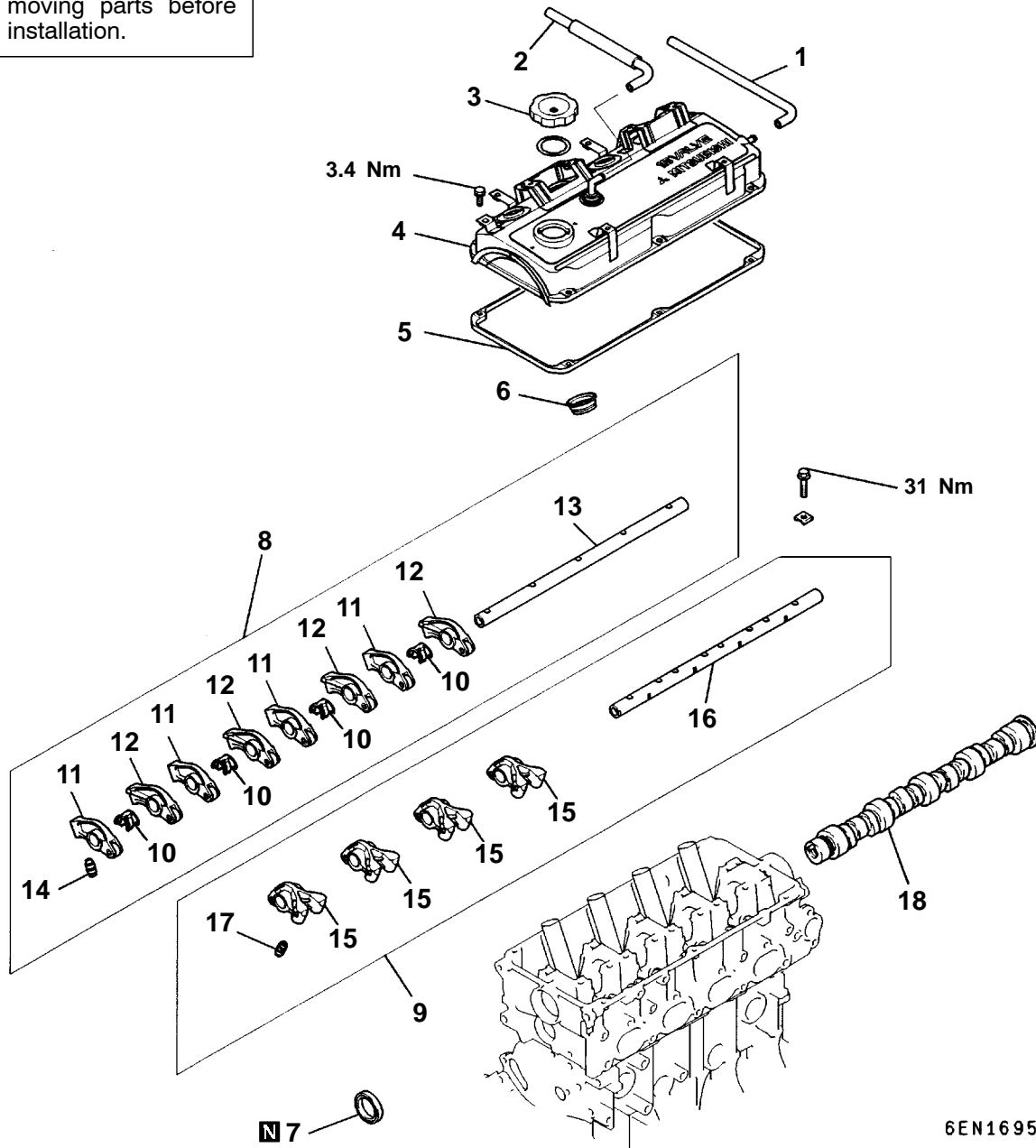

6EN1695

### Removal steps

1. Breather hose
2. P.C.V. hose
3. Oil filler cap
4. Rocker cover
5. Rocker cover gasket
6. Oil seal
7. Oil seal

- ▶B◀ 10. Rocker shaft spring
11. Rocker arm A
12. Rocker arm B
- ▶A◀ 13. Rocker arm shaft (Intake side)
- ▶A◀ 14. Lash adjuster
15. Rocker arm C
- ▶A◀ 16. Rocker arm shaft (Exhaust side)
- ▶A◀ 17. Lash adjuster
18. Camshaft

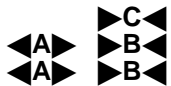

8. Rocker arms and rocker arm shaft
9. Rocker arms and rocker arm shaft

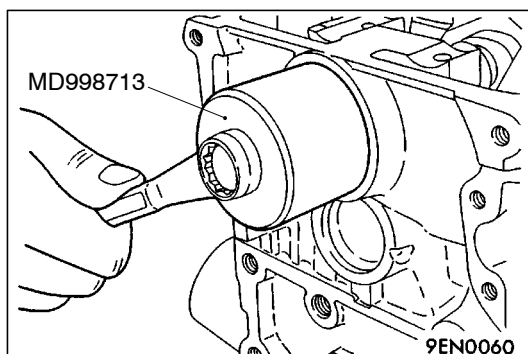
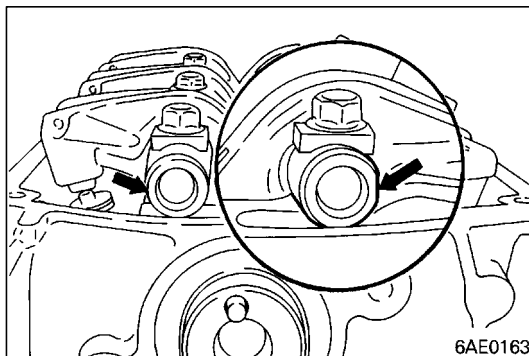
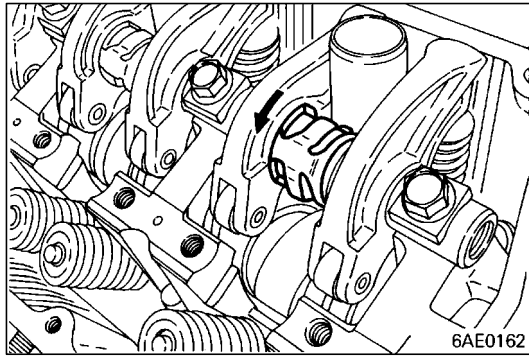
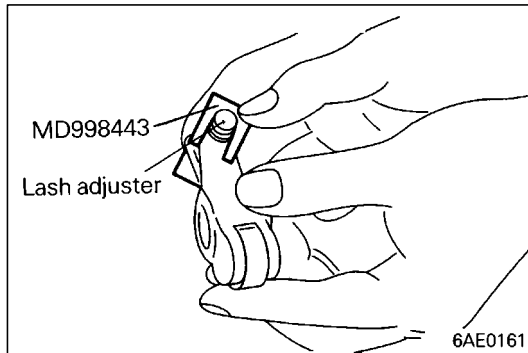
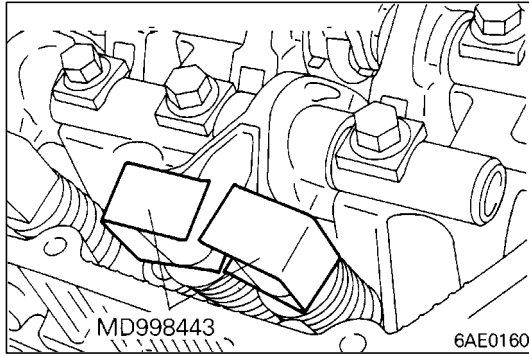

## REMOVAL SERVICE POINT

### ◀A▶ ROCKER ARMS AND ROCKER ARM SHAFTS REMOVAL

#### Caution

- If the lash adjuster is re-used, clean the lash adjuster. (Refer to 11A-8-3.)

- (1) Set special tool MD998443 to prevent the lash adjuster from coming free and falling to the floor.

## INSTALLATION SERVICE POINTS

### ▶A◀ LASH ADJUSTER INSTALLATION

- (1) Insert the lash adjuster to rocker arm, being careful not to spill the diesel fuel. Then use the special tool to prevent adjuster from falling while installing it.

#### Caution

- If the lash adjuster is re-used, clean the lash adjuster. (Refer to 11A-8-3.)

### ▶B◀ ROCKER SHAFT SPRING / ROCKER ARMS AND ROCKER ARM SHAFT INSTALLATION

- (1) Temporarily tighten the rocker shaft with the bolt so that all rocker arms on the inlet valve side do not push the valves.
- (2) Fit the rocker shaft spring from the above and position it so that it is right angles to the plug guide.

#### NOTE

Install the rocker shaft spring before installing the exhaust side rocker arms and rocker arm shaft.

- (3) Remove the special tool for securing the lash adjuster.
- (4) Make sure that the notch in the rocker arm shaft is in the direction as illustrated.

### ▶C◀ CAMSHAFT OIL SEAL INSTALLATION

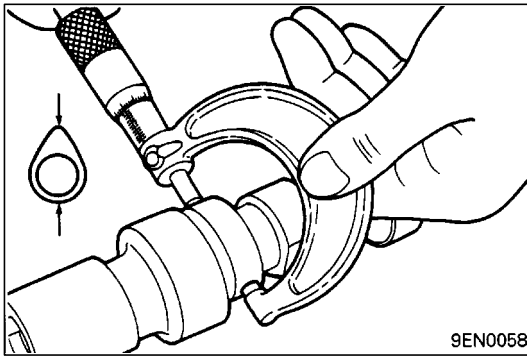

## INSPECTION

### CAMSHAFT

- (1) Measure the cam height.

Item		Standard value mm	Limit mm
GALANT	Intake	37.39	36.89
	Exhaust	37.14	36.64
SPACE WAGON	Intake	37.39	36.89
	Exhaust	36.83	36.33

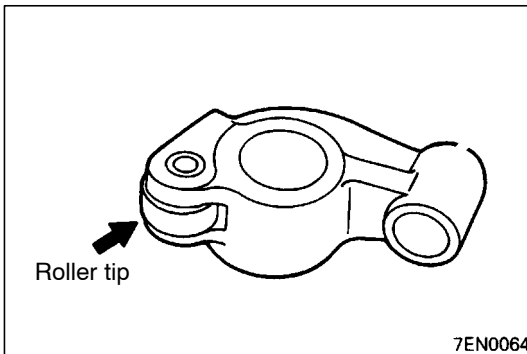

### ROCKER ARM

- (1) Check the roller surface. If any dents, damage or seizure is evident, replace the rocker arm.
- (2) Check rotation of the roller. If it does not rotate smoothly or if looseness is evident, replace the rocker arm.
- (3) Check the inside diameter. If damage or seizure is evident, replace the rocker arm.

## LASH ADJUSTERS

### Caution

- The lash adjusters are precision-engineered mechanisms. Do not allow them to become contaminated by dirt or other foreign substances.
- Do not attempt to disassemble the lash adjusters.
- Use only fresh diesel fuel to clean the lash adjusters.

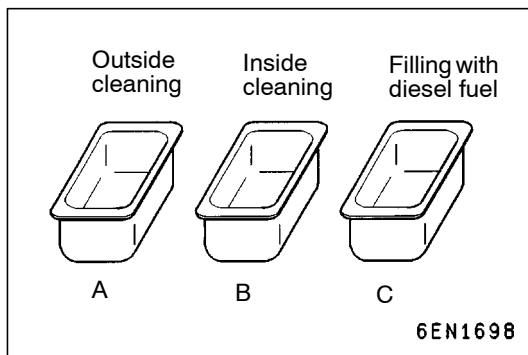

- (1) Prepare three containers and approximately five liters of diesel fuel. Into each container, pour enough diesel fuel to completely cover a lash adjuster when it is standing upright. Then, perform the following steps with each lash adjuster.

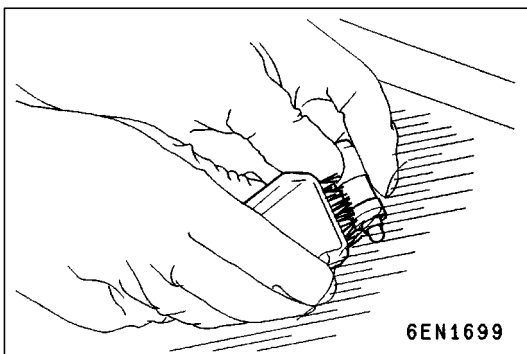

- (2) Place the lash adjuster in container A and clean its outside surface.

### NOTE

Use a nylon brush if deposits are hard to remove.

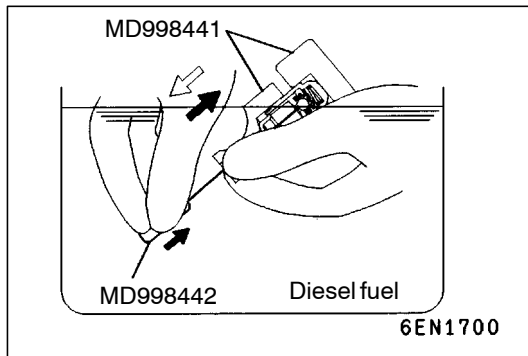

- (3) Fit special tool MD998441 onto the lash adjuster.
- (4) While gently pushing down the internal steel ball using special tool MD998442, move the plunger through 5 to 10 strokes until it slides smoothly. In addition to eliminating stiffness in the plunger, this operation will remove dirty oil.

#### Caution

- The steel ball spring is extremely weak, so the lash adjuster's functionality may be lost if the air bleed wire is pushed in hard.

#### NOTE

If the plunger remains stiff or the mechanism appears otherwise abnormal, replace the lash adjuster.

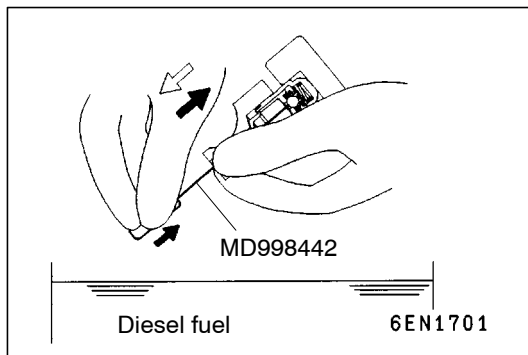

- (5) Remove the lash adjuster from the container. Then, push down the steel ball gently and push the plunger to eliminate diesel fuel from the pressure chamber.

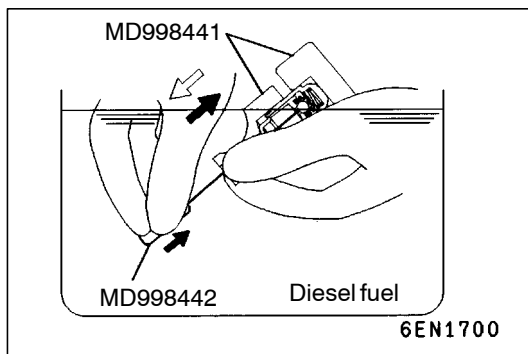

- (6) Fit special tool MD998441 onto the lash adjuster.
- (7) Place the lash adjuster in container B. Then, gently push down the internal steel ball using special tool MD998442 and move the plunger through 5 to 10 strokes until it slides smoothly. This operation will clean the lash adjuster's pressure chamber.

#### Caution

- The steel ball spring is extremely weak, so the lash adjuster's functionality may be lost if the air bleed wire is pushed in hard.

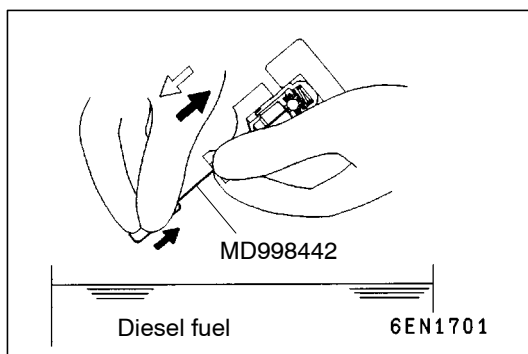

- (8) Remove the lash adjuster from the container. Then, push down the steel ball gently and push the plunger to eliminate diesel fuel from the pressure chamber.

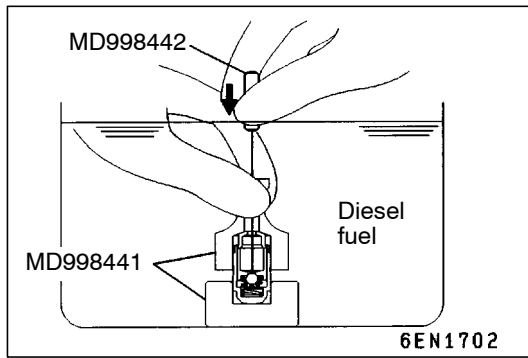

- (9) Place the lash adjuster in container C. Then, gently push down the internal steel ball using special tool MD998442.

**Caution**

- Do not use container C for cleaning. If cleaning is performed in container C, foreign matter could enter the pressure chamber when the chamber is filled with diesel fuel.

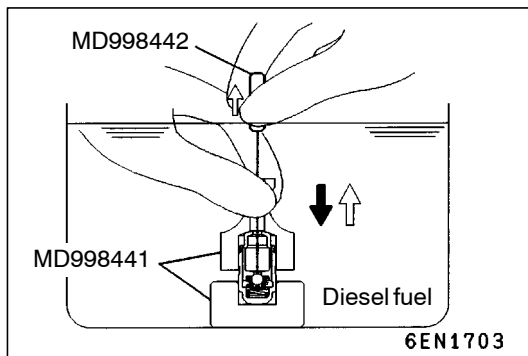

- (10) Stand the lash adjuster with its plunger at the top, then push the plunger downward firmly until it moves through its greatest possible stroke. Return the plunger slowly, then release the steel ball and allow the pressure chamber to fill diesel fuel.

- (11) Remove special tool MD998441.

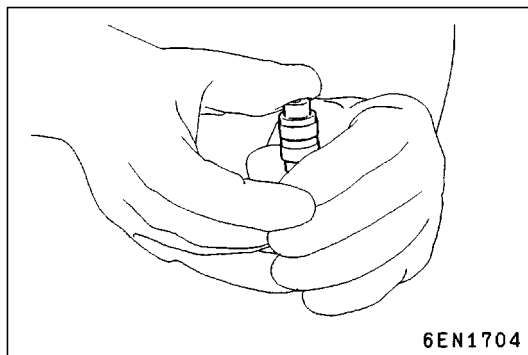

- (12) Remove the lash adjuster from the container, then stand the lash adjuster with its plunger at the top. Push the plunger firmly and check that it does not move. Also, check that the lash adjuster's height matches that of a new lash adjuster.

**NOTE**

If lash adjuster contracts, perform the operations (9) through (12) again to fill it with diesel fuel completely. Replace the lash adjuster if it still contracts after performing these steps.

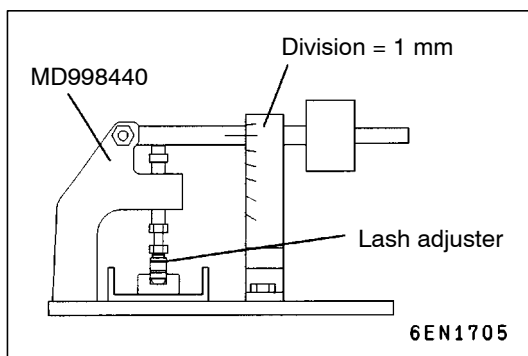

- (13) Set the lash adjuster on the special tool MD998440 (leak down tester).

- (14) After the plunger has moved downward slightly (0.2 to 0.5 mm), measure the time taken for it to move downward by a further 1 mm.

**Standard value:**

3 - 20 seconds/1 mm [with diesel fuel at 15 - 20°C (59 - 68°F)]

**NOTE**

Replace the lash adjuster if the time measurement is out of specification.



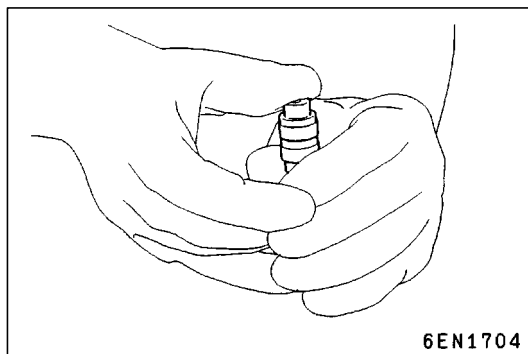
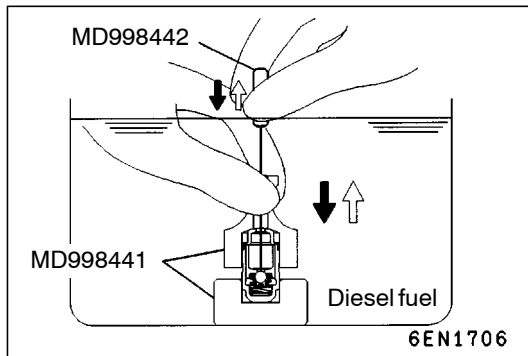

- (15) Fit special tool MD998441 onto the lash adjuster.
- (16) Place the lash adjuster in container C again, then gently push down the internal steel ball using special tool MD998442.
- (17) Stand the lash adjuster with its plunger at the top, then push the plunger downward firmly until it moves through its greatest possible stroke. Return the plunger slowly, then release the steel ball and allow the pressure chamber to fill with diesel fuel.
- (18) Remove special tool MD998441.

- (19) Remove the lash adjuster from the container, then stand the lash adjuster with its plunger at the top. Push the plunger firmly and check that it does not move. Also, check that the lash adjuster's height matches that of a new lash adjuster.

#### NOTE

If lash adjuster contracts, perform the operations (15) through (19) again to fill it with diesel fuel completely. Replace the lash adjuster if it still contracts after performing these steps.

- (20) Stand the lash adjuster upright to prevent diesel fuel spilling out. Do not allow the lash adjuster to become contaminated by dirt or other foreign matter. Fit the lash adjuster onto the engine as soon as possible.

# 8a. ROCKER ARMS AND CAMSHAFTS (GDI)

## REMOVAL AND INSTALLATION

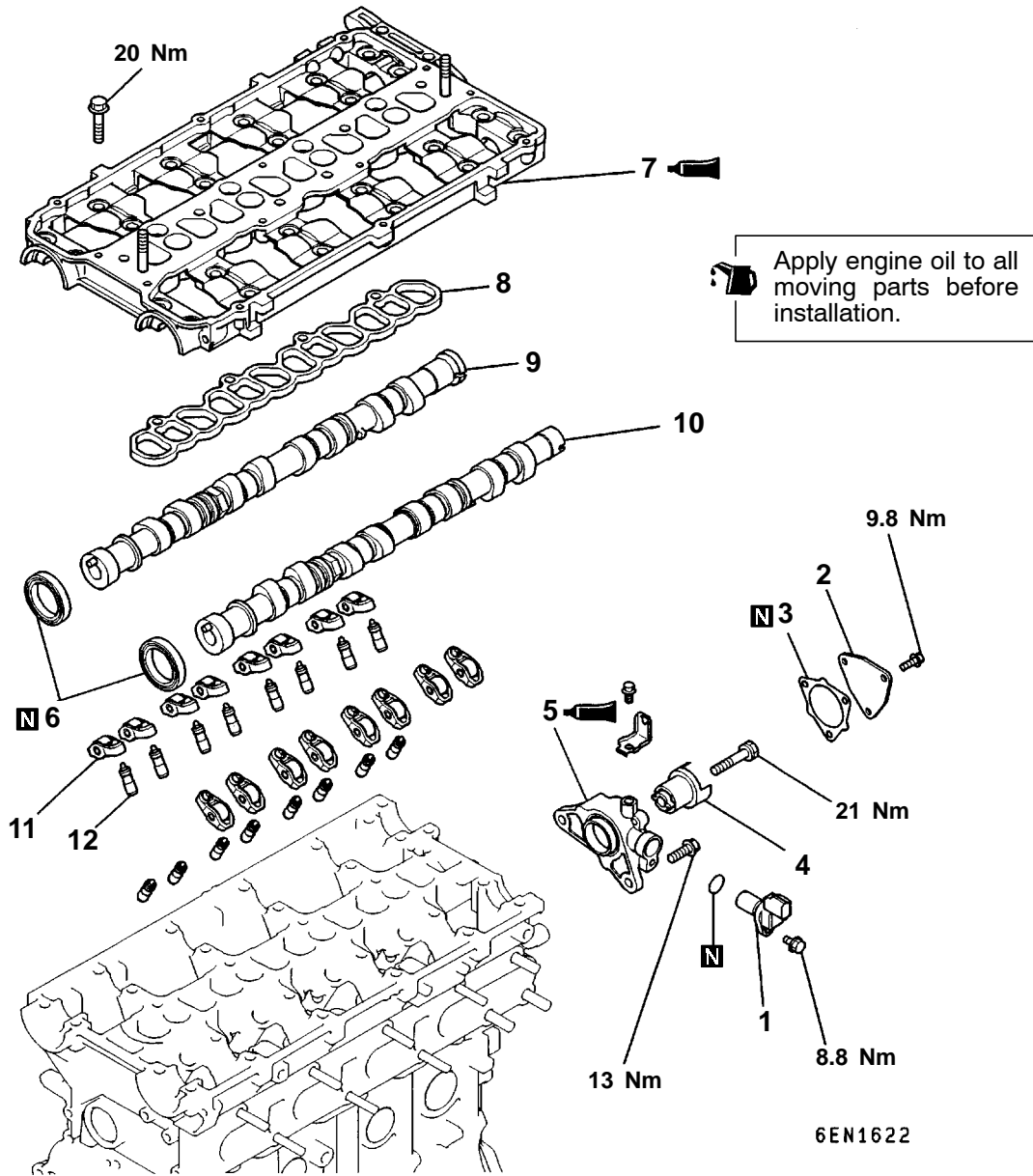

### Removal steps

- |     |   |     |                             |
|-----|---|-----|-----------------------------|
| ▶D◀ | 1. Camshaft position sensor                   | ▶B◀ | 7. Beam camshaft cap        |
| ▶C◀ | 2. Cover                                      | ▶B◀ | 8. Beam camshaft cap gasket |
|     | 3. Gasket                                     | ▶B◀ | 9. Intake camshaft          |
| ▶D◀ | 4. Camshaft position sensing cylinder         | ▶B◀ | 10. Exhaust camshaft        |
| ▶C◀ | 5. Camshaft position sensing cylinder support |     | 11. Rocker arm              |
| ▶B◀ | 6. Oil seal                                   | ◀A▶ | ▶A▶ 12. Lash adjuster       |

## REMOVAL SERVICE POINTS

### ◀A▶ LASH ADJUSTER REMOVAL

#### Caution

- If the lash adjuster is re-used, clean the lash adjuster. (Refer to 11A-8a-4.)

## INSTALLATION SERVICE POINTS

### ▶A◀ LASH ADJUSTER INSTALLATION

#### Caution

- If the lash adjuster is re-used, clean the lash adjuster. (Refer to 11A-8a-4.)

- (1) Fit the lash adjuster onto the rocker arm without allowing diesel fuel to spill out.

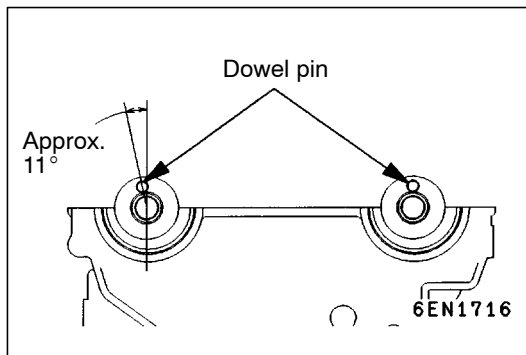

### ▶B◀ BEAM CAMSHAFT CAP GASKET / BEAM CAMSHAFT CAP / CAMSHAFT / OIL SEAL INSTALLATION

- (1) Locate the camshaft dowel pins as illustrated.

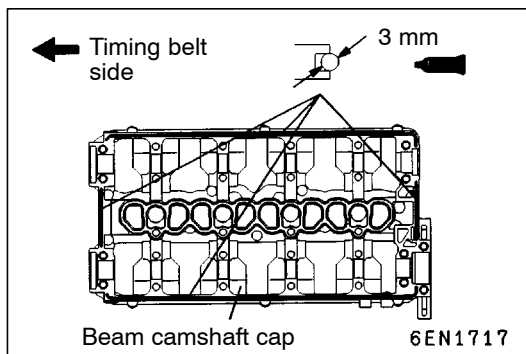

- (2) Apply a 3 mm thick continuous bead of sealant to the bottom surface of the beam camshaft cap along the groove.

#### Specified sealant:

Mitsubishi genuine Part No. MD970389 or equivalent

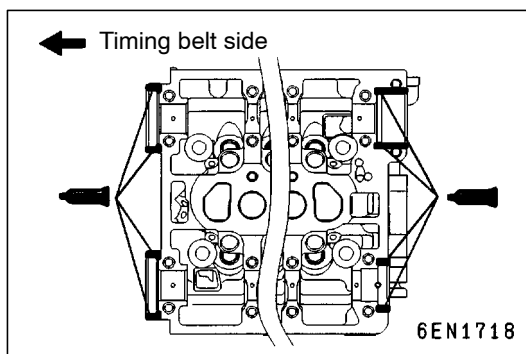

- (3) Apply sealant to the illustrated position of the cylinder head upper surface.

#### Specified sealant:

Mitsubishi genuine Part No. MD970389 or equivalent

- (4) Install the beam camshaft cap gasket.

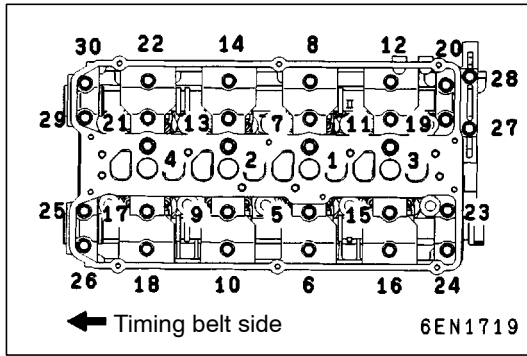

- (5) Install the beam camshaft cap before the sealant applied becomes dry and hard.
- (6) Tighten the bolts to the specified torque in the order shown in the illustration.

**Specified torque: 20 Nm**

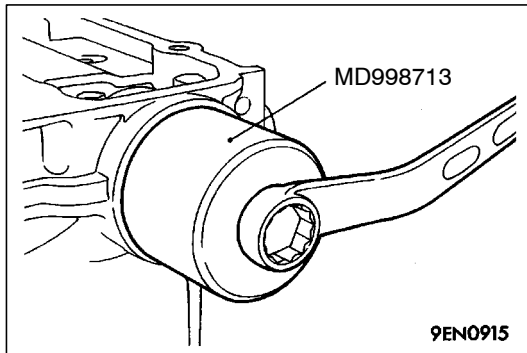

- (7) Install the camshaft oil seal before the sealant applied becomes dry and hard.
- (8) Wipe off squeezed out excess sealant from the circumference of the beam camshaft cap.

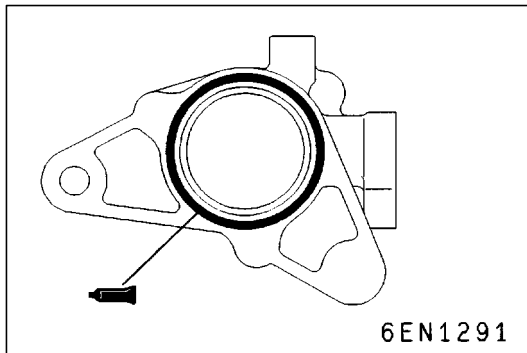

#### ▶◀ CAMSHAFT POSITION SENSING CYLINDER SUPPORT INSTALLATION

- (1) Apply a 3 mm bead of form-in-place gasket (FIG) to the area shown.

**Specified sealant:**

**Mitsubishi genuine Part No. MD970389 or equivalent**

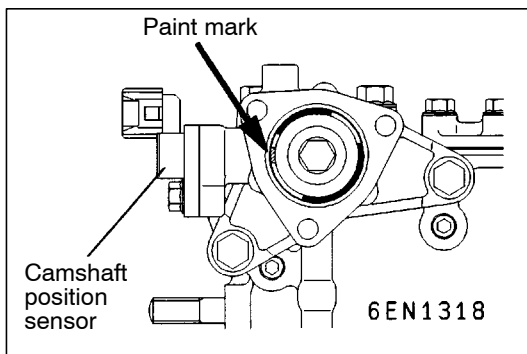

#### ▶◀ CAMSHAFT POSITION SENSING CYLINDER INSTALLATION

- (1) Set the No. 1 cylinder to the compression top dead center position (so that dowel pin of the exhaust camshaft is at the top).
- (2) Install the camshaft position sensing cylinder so that the white paint mark is facing in the direction shown in the illustration.

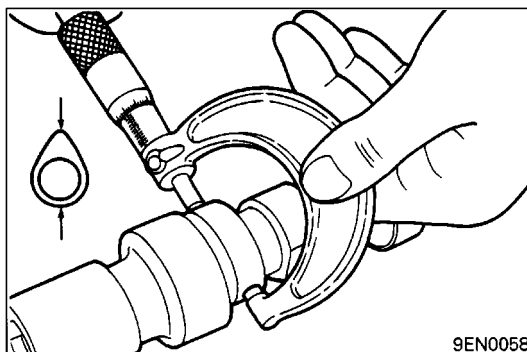

## INSPECTION

### CAMSHAFT

- (1) Measure the cam height.

**Standard value:**

**Intake 35.79 mm**  
**Exhaust 37.14 mm**

**Limit:**

**Intake 35.29 mm**  
**Exhaust 36.64 mm**

## LASH ADJUSTER

### Caution

- The lash adjusters are precision-engineered mechanisms. Do not allow them to become contaminated by dirt or other foreign substances.
- Do not attempt to disassemble the lash adjusters.
- Use only fresh diesel fuel to clean the lash adjusters.

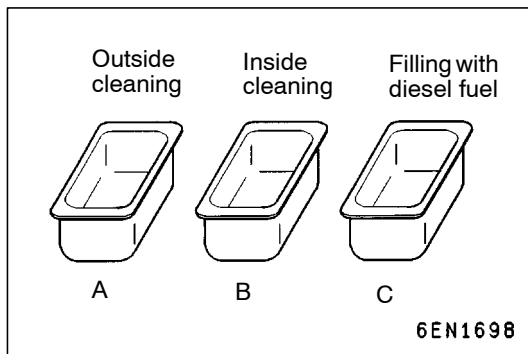

- (1) Prepare three containers and approximately five liters of diesel fuel. Into each container, pour enough diesel fuel to completely cover a lash adjuster when it is standing upright. Then, perform the following steps with each lash adjuster.

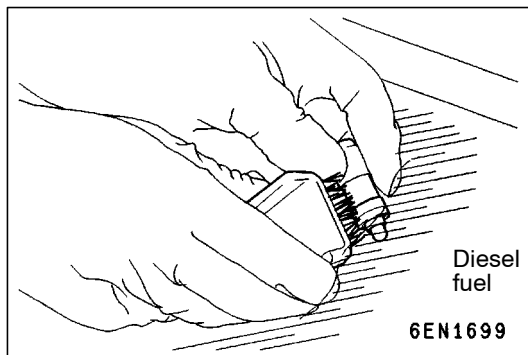

- (2) Place the lash adjuster in container A and clean its outside surface.

### NOTE

Use a nylon brush if deposits are hard to remove.

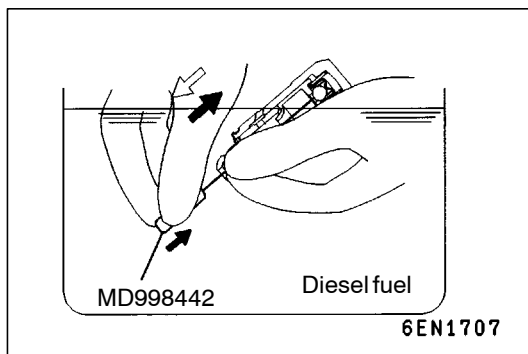

- (3) While gently pushing down the internal steel ball using special tool MD998442, move the plunger through 5 to 10 strokes until it slides smoothly. In addition to eliminating stiffness in the plunger, this operation will remove dirty oil.

### Caution

- The steel ball spring is extremely weak, so the lash adjuster's functionality may be lost if the air bleed wire is pushed in hard.

### NOTE

If the plunger remains stiff or the mechanism appears otherwise abnormal, replace the lash adjuster.

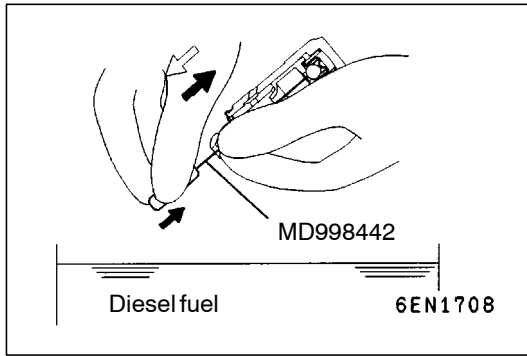

- (4) Remove the lash adjuster from the container. Then, push down the steel ball gently and push the plunger to eliminate diesel fuel from the pressure chamber.

**Caution**

- Make sure the oil hole in the side of the body is pointing toward container A. Do not point the oil hole at yourself or other people.

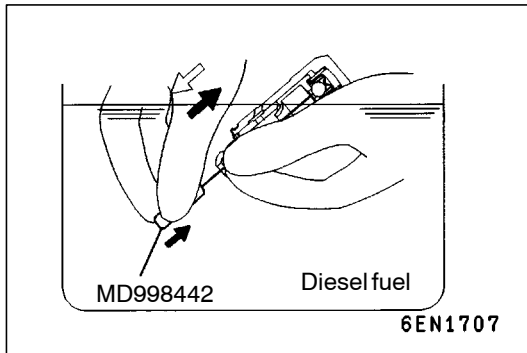

- (5) Place the lash adjuster in container B. Then, gently push down the internal steel ball using special tool MD998442 and move the plunger through 5 to 10 strokes until it slides smoothly. This operation will clean the lash adjuster's pressure chamber.

**Caution**

- The steel ball spring is extremely weak, so the lash adjuster's functionality may be lost if the air bleed wire is pushed in hard.

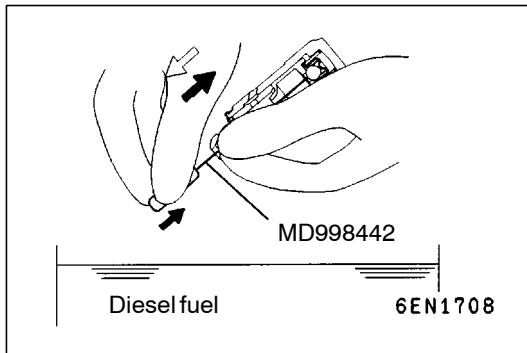

- (6) Remove the lash adjuster from the container. Then, push down the steel ball gently and push the plunger to eliminate diesel fuel from the pressure chamber.

**Caution**

- Make sure the oil hole in the side of the body is pointing toward container A. Do not point the oil hole at yourself or other people.

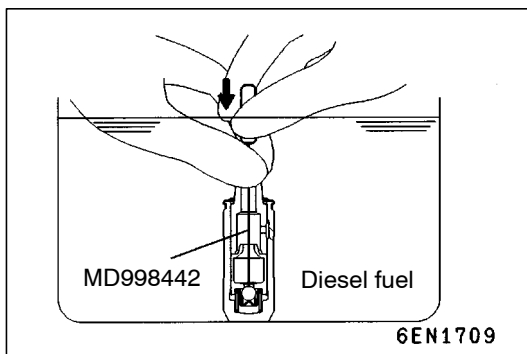

- (7) Place the lash adjuster in container C. Then, gently push down the internal steel ball using special tool MD998442.

**Caution**

- Do not use container C for cleaning. If cleaning is performed in container C, foreign matter could enter the pressure chamber when chamber is filled with diesel fuel.

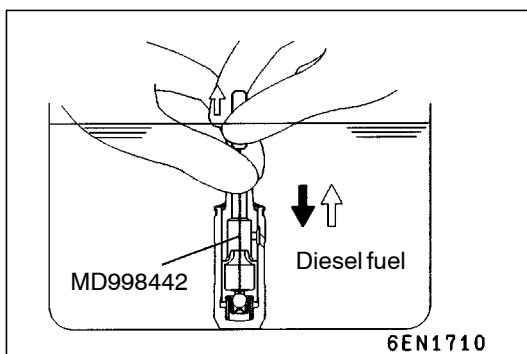

- (8) Stand the lash adjuster with its plunger at the top, then push the plunger downward firmly until it moves through its greatest possible stroke. Return the plunger slowly, then release the steel ball and allow the pressure chamber to fill with diesel fuel.

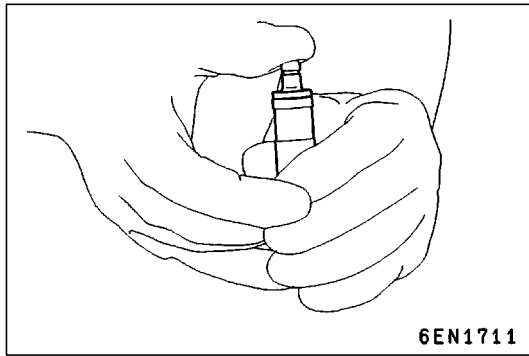

- (9) Remove the lash adjuster from the container, then stand the lash adjuster with its plunger at the top. Push the plunger firmly and check that it does not move. Also, check that the lash adjuster's height matches that of a new lash adjuster.

**NOTE**

If lash adjuster contracts, perform the operations (7) through (9) again to fill it with diesel fuel completely. Replace the lash adjuster if it still contracts after performing these steps.

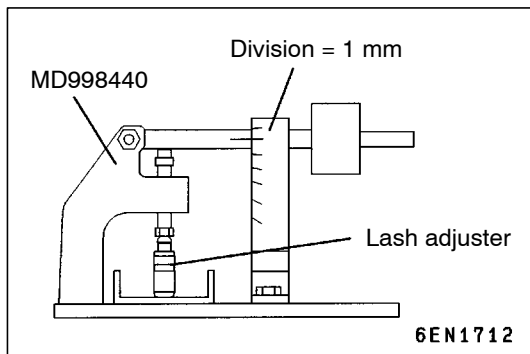

- (10) Set the lash adjuster on the special tool MD998440 (leak down tester).

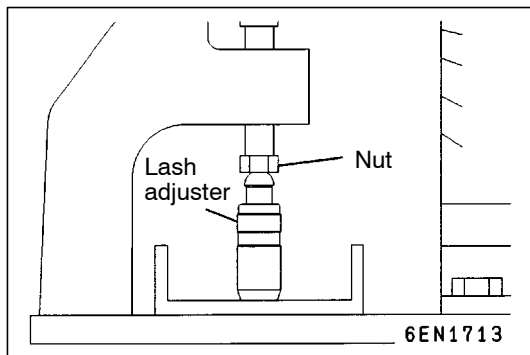

- (11) Remove the bolt from the tester, then adjust the height as illustrated.

- (12) After the plunger has moved downward slightly measure the time taken for it to move downward by a further 1 mm.

**Standard value:**

**3 - 20 second/1 mm [with diesel fuel at 15 - 20°C (59 - 68°F)]**

**NOTE**

Replace the lash adjuster if the time measurement is out of specification.

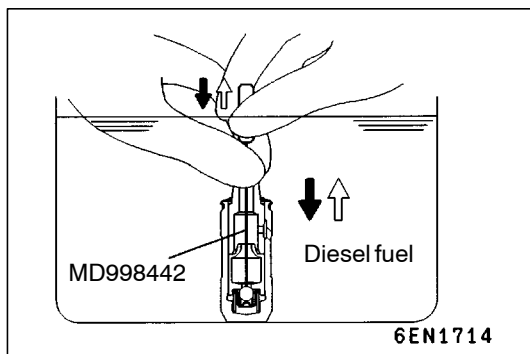

- (13) Place the lash adjuster in container C again, then gently push down the internal steel ball using special tool MD998442.

- (14) Stand the lash adjuster with its plunger at the top, then push the plunger downward firmly until it moves through its greatest possible stroke. Return the plunger slowly, then release the steel ball and allow the pressure chamber to fill with diesel fuel.

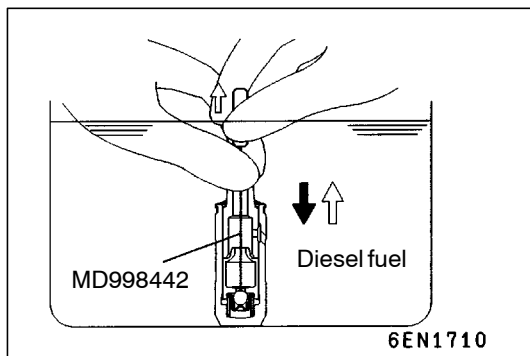

- (15) Remove the lash adjuster from the container, then stand the lash adjuster with its plunger at the top. Push the plunger firmly and check that it does not move. Also, check the lash adjuster's height matches that of a new lash adjuster.

**NOTE**

If lash adjuster contracts, perform the operations (13) through (15) again to fill it with diesel fuel completely. Replace the lash adjuster if it still contracts after performing these steps.

- (16) Stand the lash adjuster upright to prevent diesel fuel from spilling out. Do not allow the lash adjuster to become contaminated by dirt or other foreign matter. Fit the lash adjuster onto the engine as soon as possible.



# 9. CYLINDER HEAD AND VALVES

## REMOVAL AND INSTALLATION (SOHC)

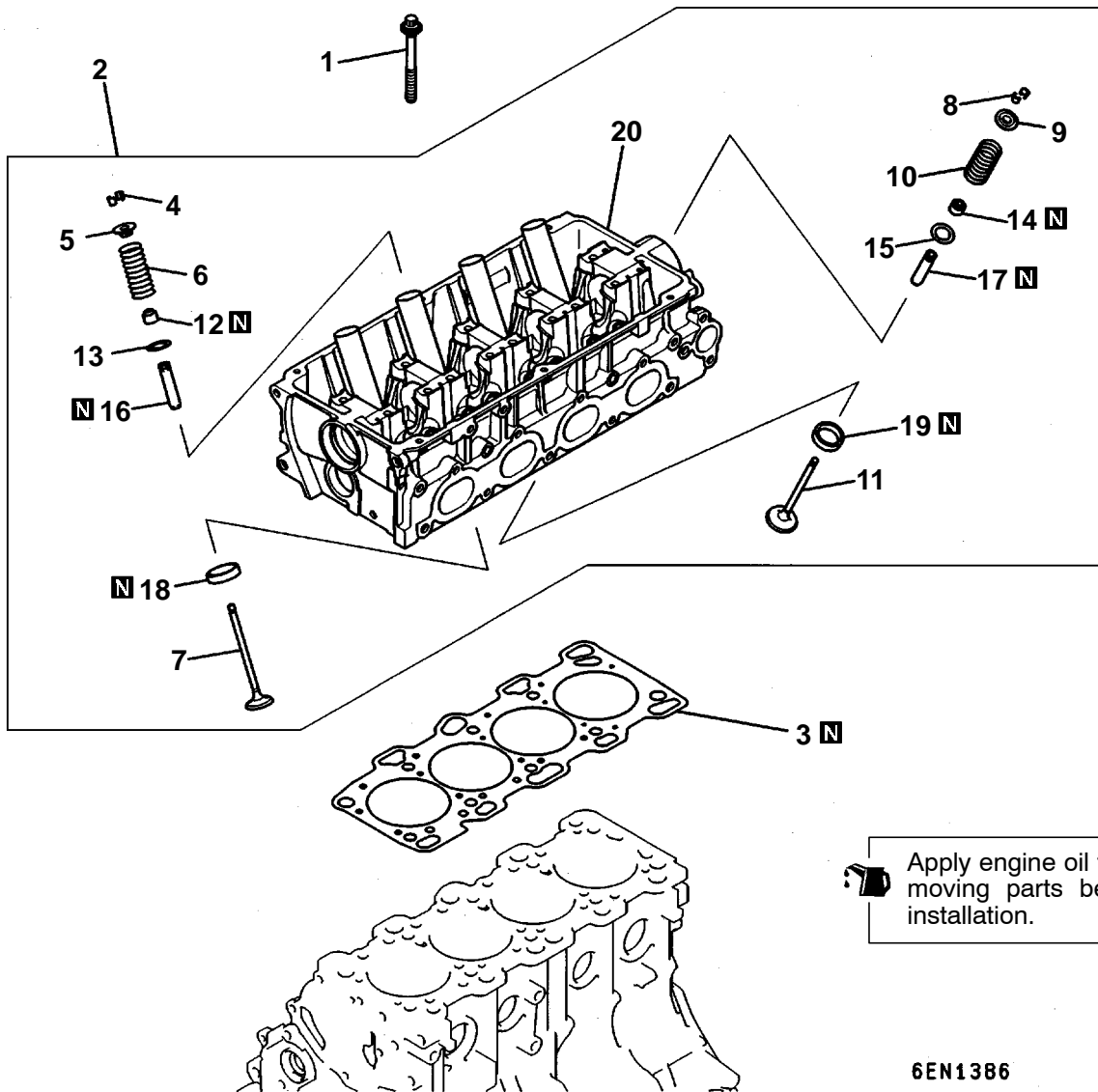

### Removal steps

- ◀A▶ ▶E◀ 1. Cylinder head bolt
- ▶A▶ ▶E◀ 2. Cylinder head assembly
- ◀B▶ ▶D▶ ▶C◀ 3. Cylinder head gasket
- ◀B▶ ▶C◀ 4. Retainer lock
- ▶B▶ ▶C◀ 5. Valve spring retainer
- ▶B▶ ▶C◀ 6. Valve spring
- ◀B▶ ▶C▶ ▶C◀ 7. Intake valve
- ▶B▶ ▶C▶ ▶C◀ 8. Retainer lock
- ▶B▶ ▶C▶ ▶C◀ 9. Valve spring retainer
- ▶B▶ ▶C▶ ▶C◀ 10. Valve spring

- ▶C▶ ▶A▶ ▶A◀ 11. Exhaust valve
- ▶C▶ ▶A▶ ▶A◀ 12. Valve stem seal
- ▶C▶ ▶A▶ ▶A◀ 13. Valve spring seat
- ▶C▶ ▶A▶ ▶A◀ 14. Valve stem seal
- ▶C▶ ▶A▶ ▶A◀ 15. Valve spring seat
- ▶C▶ ▶A▶ ▶A◀ 16. Intake valve guide
- ▶C▶ ▶A▶ ▶A◀ 17. Exhaust valve guide
- ▶C▶ ▶A▶ ▶A◀ 18. Intake valve seat
- ▶C▶ ▶A▶ ▶A◀ 19. Exhaust valve seat
- ▶C▶ ▶A▶ ▶A◀ 20. Cylinder head

REMOVAL AND INSTALLATION (GDI)

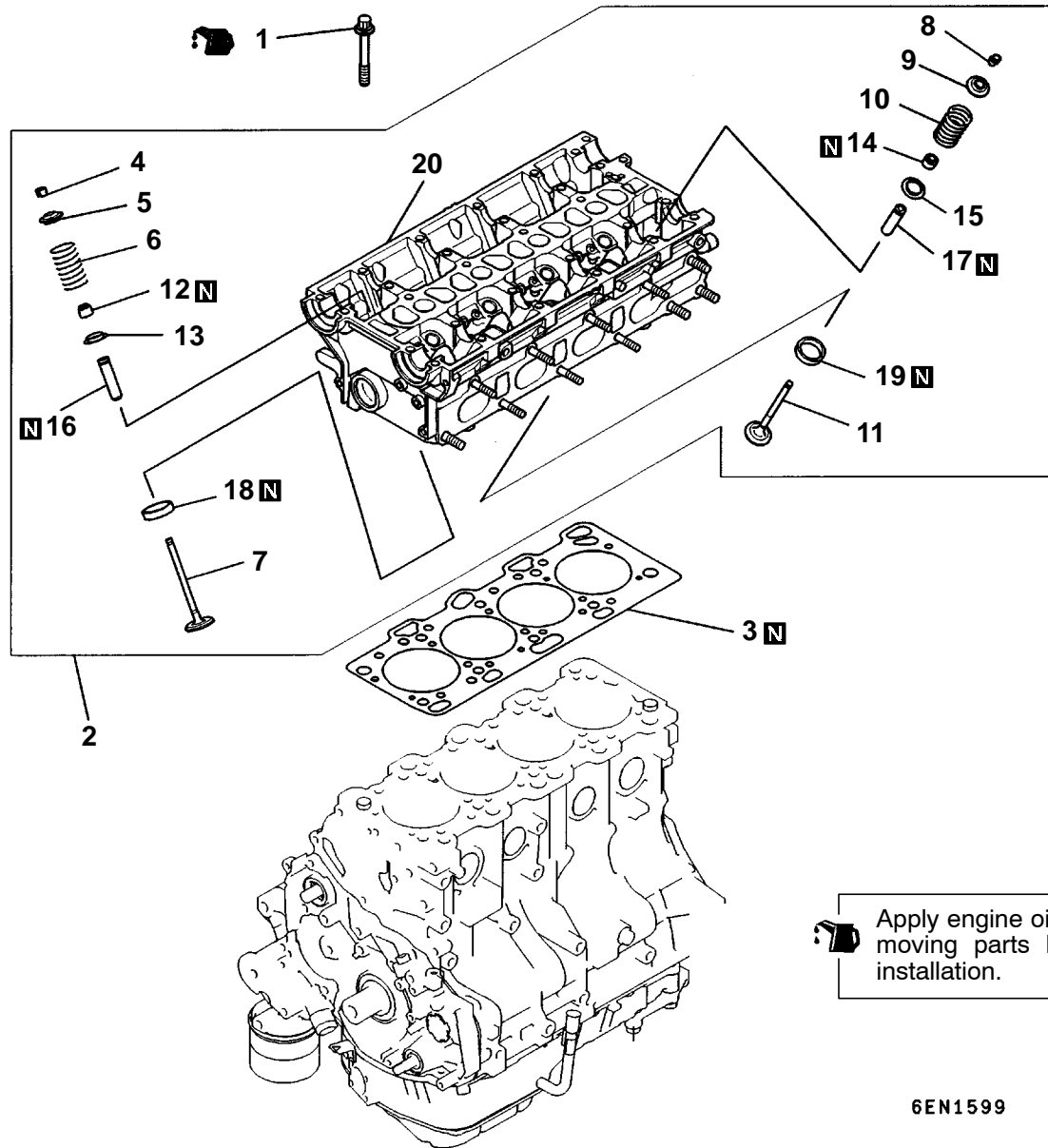

6EN1599

Removal steps

- ◀A▶ ▶E▶ 1. Cylinder head bolt
- ▶B▶ ▶C▶ 2. Cylinder head assembly
- ▶B▶ ▶C▶ 3. Cylinder head gasket
- ▶B▶ ▶C▶ 4. Retainer lock
- ▶B▶ ▶C▶ 5. Valve spring retainer
- ▶B▶ ▶C▶ 6. Valve spring
- ▶B▶ ▶C▶ 7. Intake valve
- ▶B▶ ▶C▶ 8. Retainer lock
- ▶B▶ ▶C▶ 9. Valve spring retainer
- ▶B▶ ▶C▶ 10. Valve spring

- ▶C▶ ▶A▶ 11. Exhaust valve
- ▶C▶ ▶A▶ 12. Valve stem seal
- ▶C▶ ▶A▶ 13. Valve spring seat
- ▶C▶ ▶A▶ 14. Valve stem seal
- ▶C▶ ▶A▶ 15. Valve spring seat
- ▶C▶ ▶A▶ 16. Intake valve guide
- ▶C▶ ▶A▶ 17. Exhaust valve guide
- ▶C▶ ▶A▶ 18. Intake valve seat
- ▶C▶ ▶A▶ 19. Exhaust valve seat
- ▶C▶ ▶A▶ 20. Cylinder head

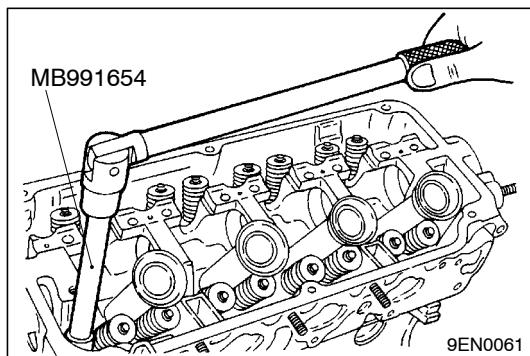
**REMOVAL SERVICE POINTS****PRECAUTION FOR REMOVED PARTS**

Keep removed parts in order according to the cylinder number and intake/exhaust.

**◀A▶ CYLINDER HEAD BOLTS REMOVAL**

- (1) Using the special tool, loosen the cylinder head bolts. Loosen evenly, little by little.

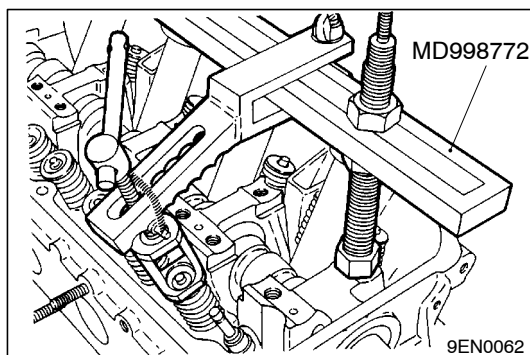
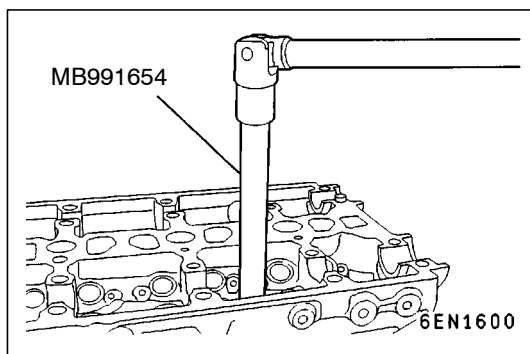
**◀B▶ RETAINER LOCK REMOVAL**

- (1) Store removed valves, springs and other parts, tagged to indicate their cylinder No. and location for reassembly.

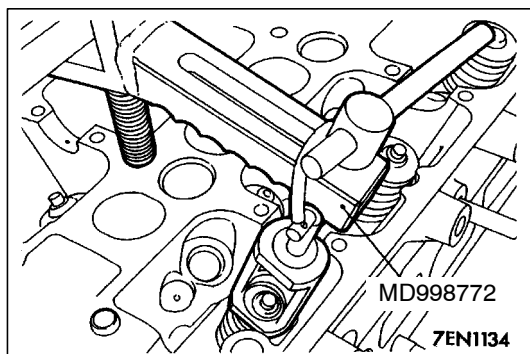

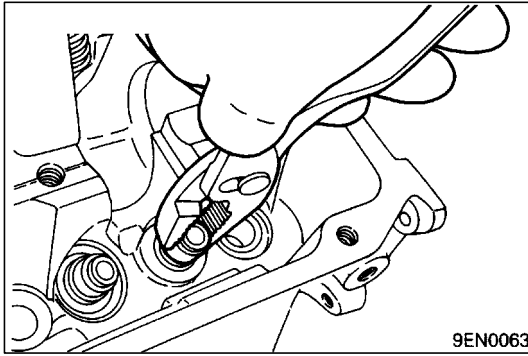

### ◀C▶ VALVE STEM SEAL REMOVAL

- (1) Do not reuse removed stem seal.

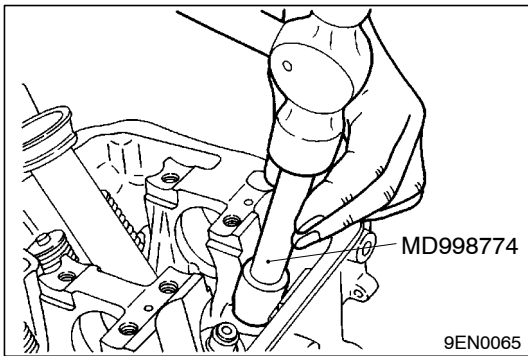
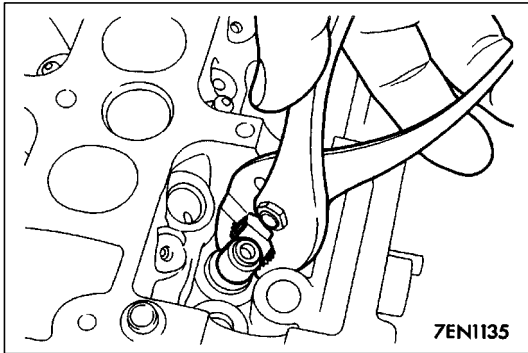

### INSTALLATION SERVICE POINTS

#### ▶A▶ VALVE STEM SEAL INSTALLATION

- (1) Install the valve spring seat.
- (2) The special tool must be used to install the valve stem seal. Improper installation could result in oil leaks past the valve guide.

#### Caution

- Do not reuse removed valve stem seals.

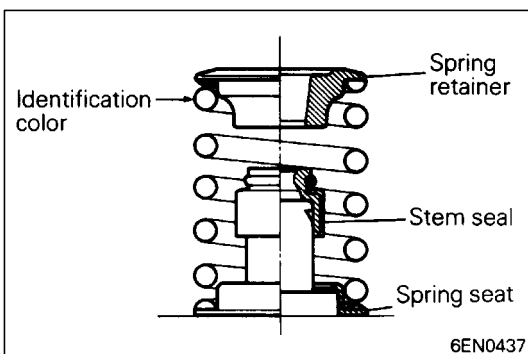
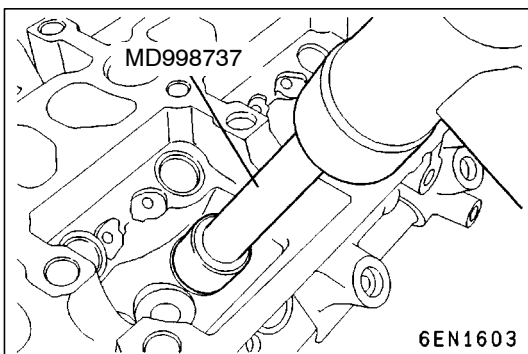

#### ▶B▶ VALVE SPRING INSTALLATION

- (1) Direct the valve spring end with identification color toward the spring retainer.

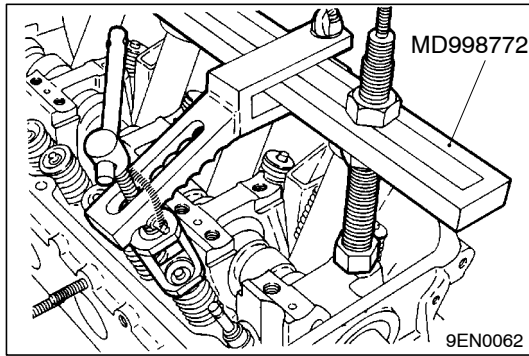

### ▶◀ RETAINER LOCK INSTALLATION

- (1) The valve spring, if excessively compressed, causes the bottom end of the retainer to be in contact with, and damage, the stem seal.

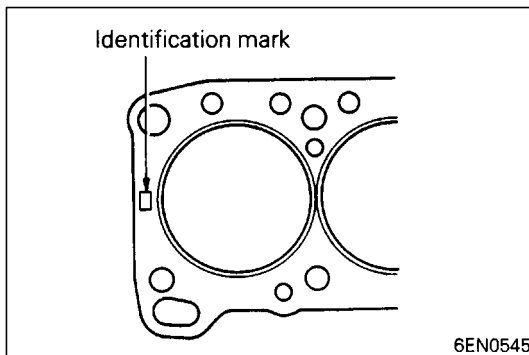
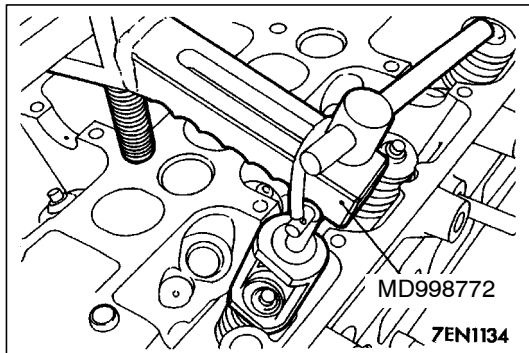

### ▶◀ CYLINDER HEAD GASKET IDENTIFICATION

Identification mark: 4G63N

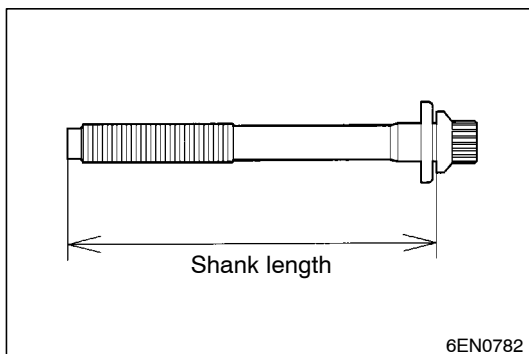

### ▶◀ CYLINDER HEAD BOLT INSTALLATION

- (1) When installing the cylinder head bolts, check that the shank length of each bolt meets the limit. If the limit is exceeded, replace the bolt.

**Limit: Max. 99.4 mm**

- (2) Apply engine oil to the bolt threads and to the washers.

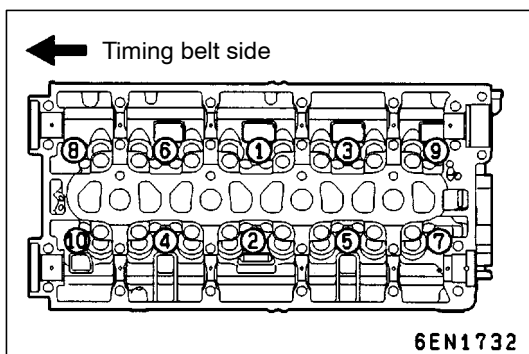

- (3) Using the special tool (MB991654) and according to the tightening sequence, tighten the bolts to the specified torque.

**Tightening torque: 78 Nm**

- (4) Loosen all bolts fully.
- (5) Retighten the loosened bolts to a torque of 20 Nm in the specified tightening sequence.

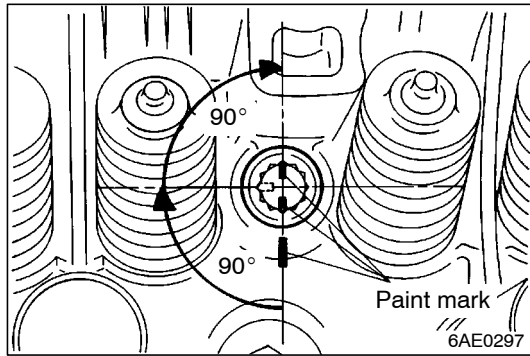

- (6) Make paint marks on the cylinder head bolt heads and cylinder head.
- (7) Give a 90° turn to the cylinder head bolts in the specified tightening sequence.
- (8) Give another 90° turn to the cylinder head bolts and make sure that the paint mark on the head of each cylinder head bolt and that on the cylinder head are on the same straight line.

#### Caution

- If the bolt is turned less than 90°, proper fastening performance may not be expected. When tightening the bolt, therefore, be careful to give a sufficient turn to it.
- If the bolt is overtightened, loosen the bolt completely and then retighten it by repeating the tightening procedure from step (1).

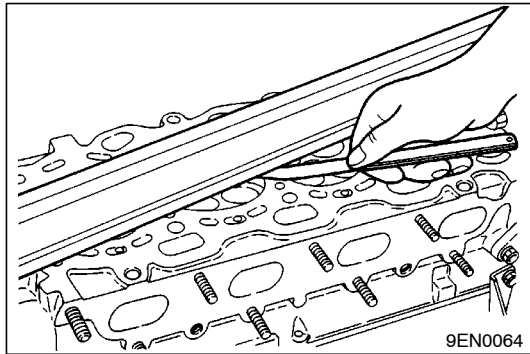

## INSPECTION

### CYLINDER HEAD

- (1) Check the cylinder head gasket surface for flatness by using a straightedge and thickness gauge.

**Standard value: 0.05 mm**

**Limit: 0.2 mm**

- (2) If the service limit is exceeded, correct to meet specification.

**Grinding limit: \*0.2 mm**

\* Includes combined with cylinder block grinding.

**Cylinder head height (Specification when new):**

**SOHC 119.9 - 120.1 mm**

**GDI 131.9 - 132.1 mm**

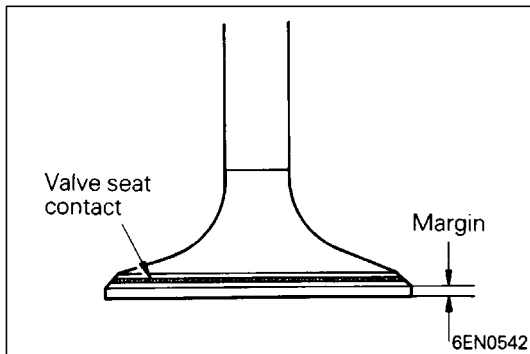

**VALVE**

- (1) Check the valve face for correct contact. If incorrect, reface using a valve refacer. Valve seat contact should be maintained uniform at the center of valve face.
- (2) If the margin exceeds the service limit, replace the valve.

Item		Standard value mm	Limit mm
SOHC	Intake	1.0	0.5
	Exhaust	1.2	0.7
GDI	Intake	1.0	0.5
	Exhaust	1.5	1.0

- (3) Measure valve's total length. If measurement is less than specified, replace the valve.

Item		Standard value mm	Limit mm
SOHC	Intake	112.30	111.80
	Exhaust	114.11	113.61
GDI	Intake	105.5	105.0
	Exhaust	105.7	105.2

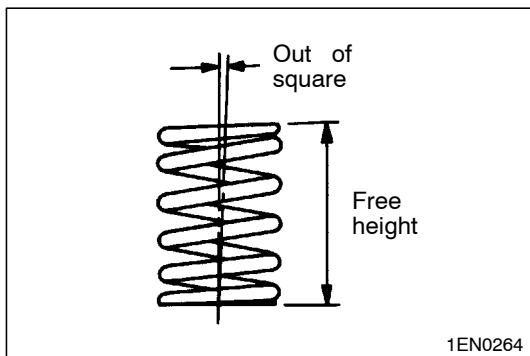

**VALVE SPRING**

- (1) Measure the free height of spring and, if it is smaller than the limit, replace.

Item	Standard value mm	Limit mm
SOHC	51.0	50.0
GDI	48.3	47.3

- (2) Measure the squareness of the spring and, if the limit is exceeded, replace.

Item	Standard value mm	Limit mm
SOHC	2°	4°
GDI	1.5°	4°

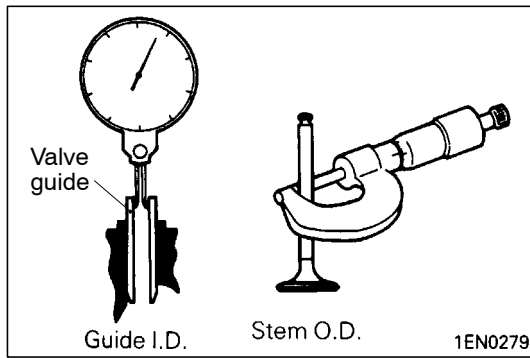

### VALVE GUIDE

- (1) Measure the clearance between the valve guide and valve stem. If the limit is exceeded, replace the valve guide or valve, or both.

Item		Standard value mm	Limit mm
SOHC	Intake	0.02 - 0.05	0.10
	Exhaust	0.03 - 0.07	0.15
GDI	Intake	0.02 - 0.05	0.10
	Exhaust	0.05 - 0.09	0.15

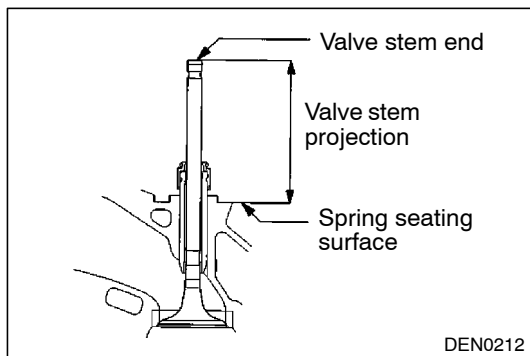

### VALVE SEAT

- (1) Assemble the valve, then measure the valve stem projection between the end of the valve stem and the spring seating surface. If the measurement exceeds the specified limit, replace the valve seat.

Item		Standard value mm	Limit mm
SOHC	Intake	49.30	49.80
	Exhaust	49.30	49.80
GDI	Intake	49.20	49.70
	Exhaust	48.40	48.90

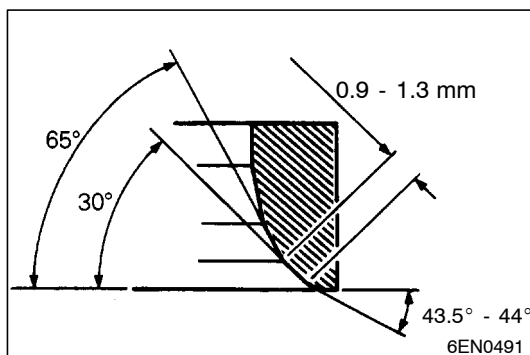

### VALVE SEAT RECONDITIONING PROCEDURE

- (1) Before correcting the valve seat, check for clearance between the valve guide and valve and, if necessary, replace the valve guide.
- (2) Using the seat grinder, correct to obtain the specified seat width and angle.
- (3) After correcting the valve seat, lap the valve and valve seat using lapping compound. Then, check the valve stem projection (refer to VALVE SEAT in INSPECTION).



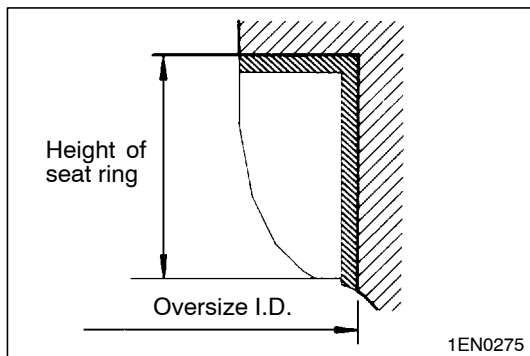
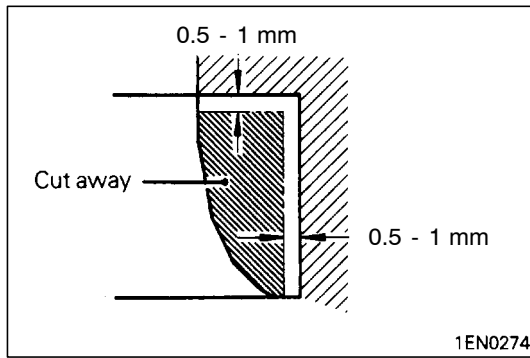

## VALVE SEAT REPLACEMENT PROCEDURE

- (1) Cut the valve seat to be replaced from the inside to thin the wall thickness. Then, remove the valve seat.

- (2) Rebore the valve seat hole in the cylinder head to a selected oversize valve seat diameter.

### Valve seat ring hole diameter

Item			Standard value mm
SOHC	Intake	0.30 O.S.	34.30 - 34.33
		0.60 O.S.	34.60 - 34.63
	Exhaust	0.30 O.S.	31.80 - 31.83
		0.60 O.S.	32.60 - 32.63
GDI	Intake	0.30 O.S.	35.30 - 35.33
		0.60 O.S.	35.60 - 35.63
	Exhaust	0.30 O.S.	33.30 - 33.33
		0.60 O.S.	33.60 - 33.63

- (3) Before fitting the valve seat, either heat the cylinder head up to approximately 250°C (482°F) or cool the valve seat in liquid nitrogen, to prevent the cylinder head bore from galling.
- (4) Using a valve seat cutter, correct the valve seat to the specified width and angle.  
See "VALVE SEAT RECONDITIONING PROCEDURE".

**VALVE GUIDE REPLACEMENT PROCEDURE**

- (1) Force the valve guide out toward the cylinder block using a press.
- (2) Machine the valve guide hole in the cylinder head to the size of the oversize valve guide to be installed.

**Caution**

- **Do not use the valve guide of the same size as the removed one.**

**Valve gauge hole diameters in cylinder head**

Item		Standard value mm
SOHC	0.05 O.S.	11.05 - 11.07
	0.25 O.S.	11.25 - 11.27
	0.50 O.S.	11.50 - 11.52
GDI	0.05 O.S.	12.05 - 12.07
	0.25 O.S.	12.25 - 12.27
	0.50 O.S.	12.50 - 12.52

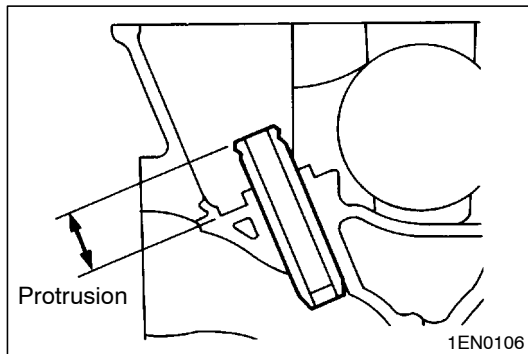

- (3) Press-fit the valve guide until it protrude specified value (SOHC 14 mm, GDI 19.5 mm) as shown in the illustration.

**Caution**

- **Press the valve guide from the cylinder head top surface.**
  - **Valve guide for intake valve and that for exhaust valve are different in length. (45.5 mm for intake valve; 50.5 mm for exhaust valve)**
- (4) After the valve guide has been installed, insert a new valve to check for smooth sliding motion.

# 10. FRONT CASE, COUNTERBALANCE SHAFTS AND OIL PAN

## REMOVAL AND INSTALLATION <GDI ENGINE - VEHICLE FOR EUROPE AND SOHC ENGINE>

Apply engine oil to all moving parts before installation.

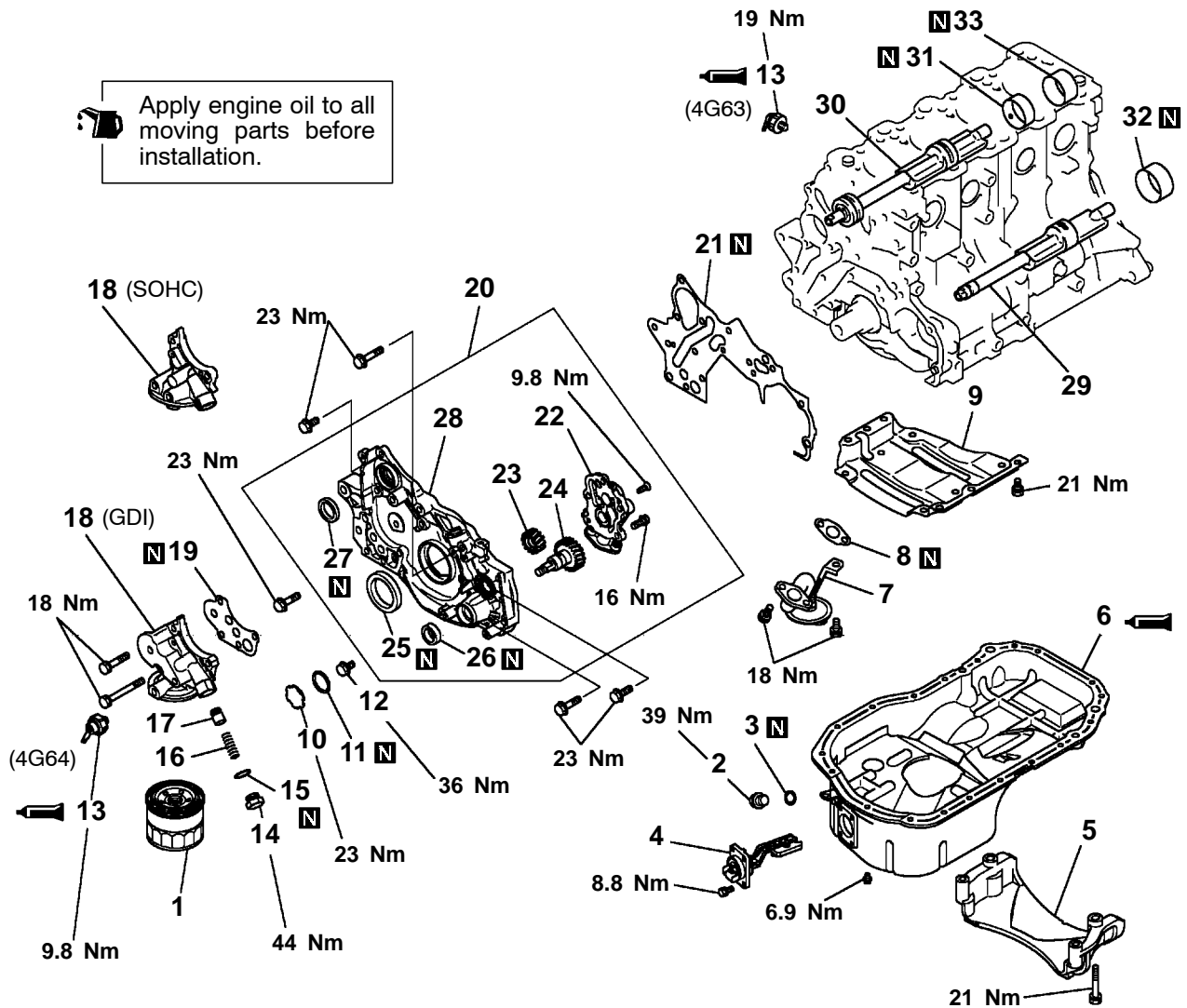

6EN1851

### Removal steps

- |         |   |  |
|---------|---|--|
| ▶O◀     | 1. Oil filter                                   | 18. Oil filter bracket                               |
| ▶N◀     | 2. Drain plug                                   | 19. Oil filter bracket gasket                        |
|         | 3. Drain plug gasket                            | ▶H◀ 20. Front case assembly                          |
|         | 4. Oil level sensor                             | 21. Front case gasket                                |
| ◀A▶ ▶L◀ | 5. Transmission stay (GDI engine)               | 22. Oil pump cover                                   |
|         | 6. Oil pan                                      | ▶G◀ 23. Oil pump driven gear                         |
|         | 7. Oil screen                                   | ▶G◀ 24. Oil pump drive gear                          |
|         | 8. Oil screen gasket                            | ▶F◀ 25. Crankshaft front oil seal                    |
|         | 9. Stiffener (SOHC engine - vehicle for Europe) | ▶E◀ 26. Oil pump oil seal                            |
| ◀D▶ ▶K◀ | 10. Plug  | ▶D◀ 27. Counterbalance shaft oil seal                |
|         | 11. O-ring                                      | 28. Front case                                       |
| ◀E▶ ▶J◀ | 12. Flange bolt                                 | 29. Counterbalance shaft, left                       |
| ▶I◀     | 13. Oil pressure switch                         | 30. Counterbalance shaft, right                      |
|         | 14. Relief plug                                 | ◀F▶ ▶C◀ 31. Counterbalance shaft front bearing       |
|         | 15. Relief plug gasket                          | ◀G▶ ▶B◀ 32. Counterbalance shaft rear bearing, left  |
|         | 16. Relief spring                               | ◀G▶ ▶A◀ 33. Counterbalance shaft rear bearing, right |
|         | 17. Relief plunger                              |  |

REMOVAL AND INSTALLATION <GDI ENGINE - VEHICLE FOR HONG KONG>

Apply engine oil to all moving parts before installation.

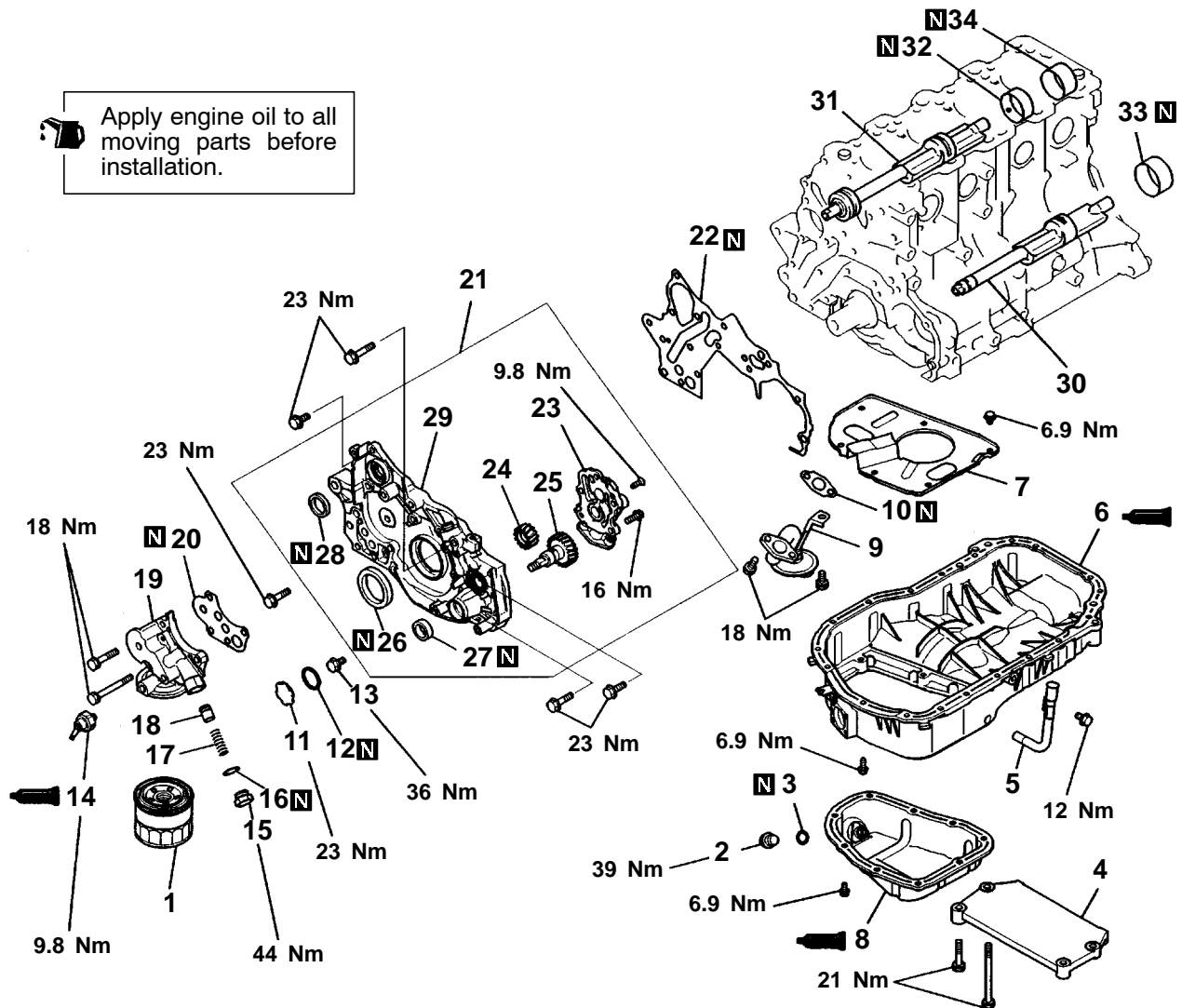

6EN1738

Removal steps

- |     |                          |                               |  |
|-----|--------------------------|-------------------------------|--|
| ▶O◀ | 1. Oil filter            | 19. Oil filter bracket        |  |
| ▶N◀ | 2. Drain plug            | 20. Oil filter bracket gasket |  |
| ▶N◀ | 3. Drain plug gasket     | ▶H◀                           | 21. Front case assembly                      |
| ▶M◀ | 4. Transmission stay     | ▶H◀                           | 22. Gasket                                   |
| ▶M◀ | 5. Oil level gauge guide | ▶G◀                           | 23. Oil pump cover                           |
| ▶M◀ | 6. Oil pan lower         | ▶G◀                           | 24. Oil pump driven gear                     |
| ▶M◀ | 7. Baffle plate          | ▶G◀                           | 25. Oil pump drive gear                      |
| ▶M◀ | 8. Oil pan upper         | ▶F◀                           | 26. Crankshaft front oil seal                |
| ▶M◀ | 9. Oil screen            | ▶E◀                           | 27. Oil pump oil seal                        |
| ▶K◀ | 10. Gasket               | ▶D◀                           | 28. Counterbalance shaft oil seal            |
| ▶K◀ | 11. Plug                 | ▶D◀                           | 29. Front case                               |
| ▶J◀ | 12. O-ring               | ▶D◀                           | 30. Counterbalance shaft, left               |
| ▶J◀ | 13. Flange bolt          | ▶D◀                           | 31. Counterbalance shaft, right              |
| ▶I◀ | 14. Oil pressure switch  | ▶C◀                           | 32. Counterbalance shaft front bearing       |
| ▶I◀ | 15. Relief plug          | ▶B◀                           | 33. Counterbalance shaft rear bearing, left  |
|     | 16. Gasket               | ▶A◀                           | 34. Counterbalance shaft rear bearing, right |
|     | 17. Relief spring        |                               |  |
|     | 18. Relief plunger       |                               |  |

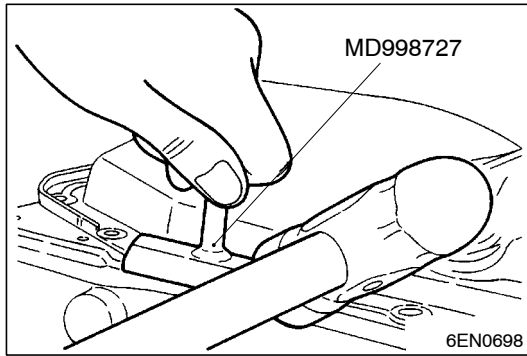

## REMOVAL SERVICE POINTS

### ◀A▶ OIL PAN REMOVAL

- (1) Remove all oil pan bolts.
- (2) Drive in the special tool between the cylinder block and oil pan.

#### NOTE

Never use a screwdriver or chisel, instead of the service tool, as a deformed oil pan flange will result in oil leakage.

### ◀B▶ OIL PAN LOWER REMOVAL

- (1) Apply a wood block to the oil pan side and remove the oil pan lower by tapping lightly on it with a plastic hammer.

#### Caution

- Do not use a scraper or special tool to remove the oil pan.

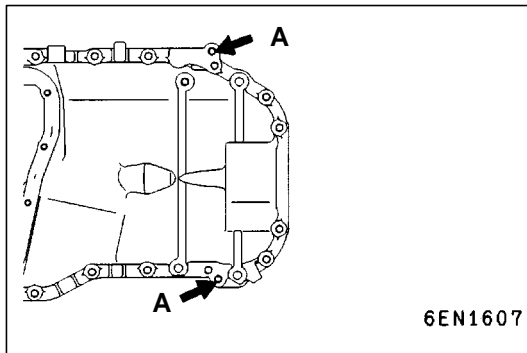

### ◀C▶ OIL PAN UPPER REMOVAL

- (1) Remove all bolts.
- (2) Screw a bolt into bolt hole A shown to remove the oil pan.

#### Caution

- Do not use a scraper or special tool to remove the oil pan.

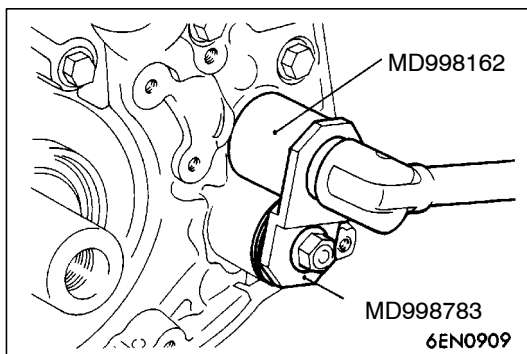

### ◀D▶ PLUG REMOVAL

- (1) If the plug is too tight, hit the plug head with a hammer two to three times, and the plug will be easily loosened.

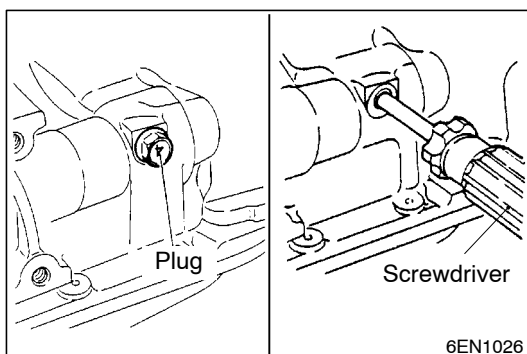

### ◀E▶ FLANGE BOLT REMOVAL

- (1) Remove the plug on the side of cylinder block.
- (2) Insert a Phillips screwdriver (shank diameter 8 mm) into the plug hole to lock the counterbalance shaft.

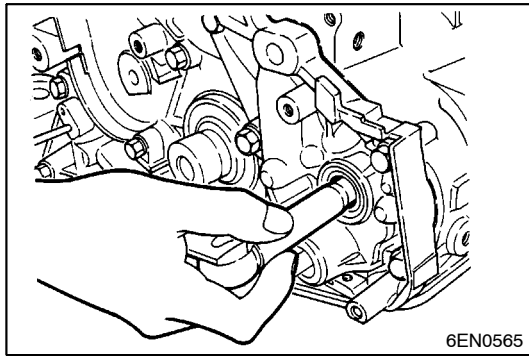

- (3) Loosen the flange bolt.

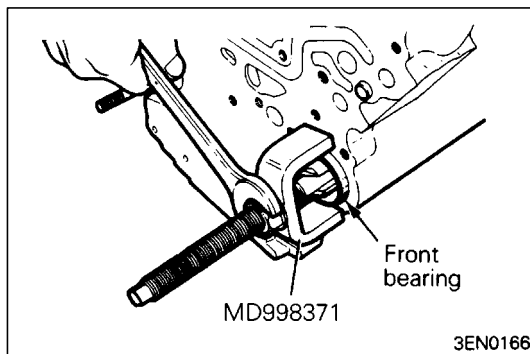

### ◀F▶ COUNTERBALANCE SHAFT FRONT BEARING REMOVAL

- (1) Using the special tool, remove the counterbalance shaft front bearing from the cylinder block.

#### NOTE

Be sure to remove the front bearing first.

If it has not been removed, the Rear Bearing Puller cannot be used.

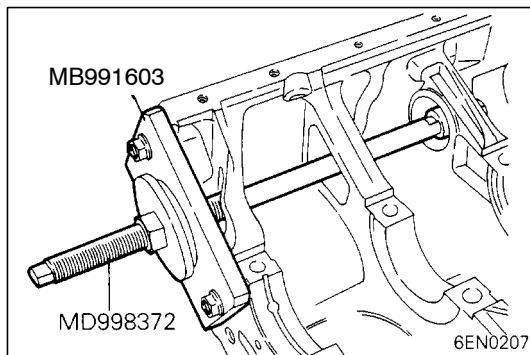

### ◀G▶ COUNTERBALANCE SHAFT REAR BEARING REMOVAL

- (1) Using the special tool, remove the left counterbalance shaft rear bearing from the cylinder block.

#### NOTE

When removing the left counterbalance shaft rear bearing, install the special tool (MB991603) in front of the cylinder block.

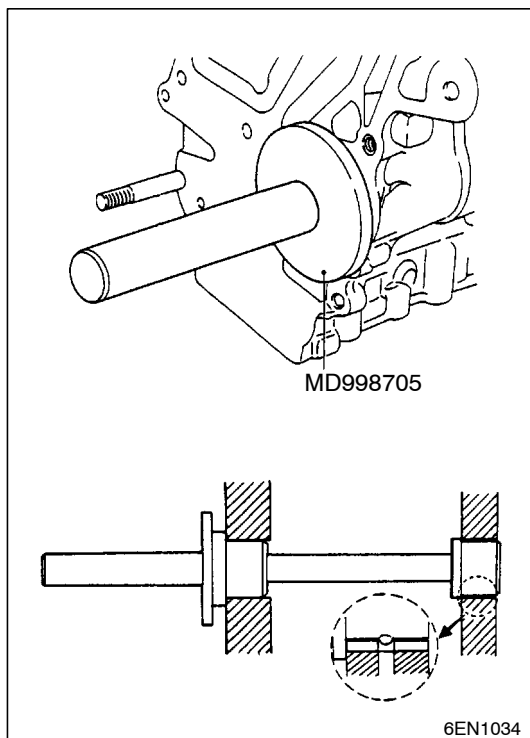

## INSTALLATION SERVICE POINTS

### ▶A◀ RIGHT COUNTERBALANCE SHAFT REAR BEARING INSTALLATION

- (1) Apply engine oil to the outer surface of bearing.  
 (2) Using special tools, install right rear bearing. Make sure that oil hole of bearing is aligned with oil hole of cylinder block.

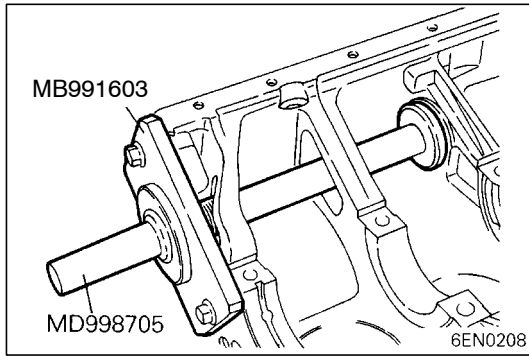

**▶B◀ LEFT COUNTERBALANCE SHAFT REAR BEARING INSTALLATION**

- (1) Install the special tool (Guide Plate) to the cylinder block.
- (2) Apply engine oil to the rear bearing outer circumference and bearing hole in the cylinder block.

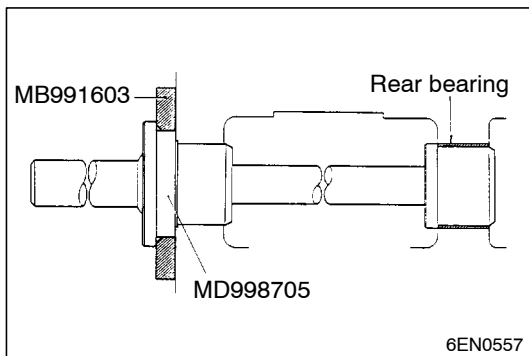

- (3) Using the special tool, install the rear bearing.

**NOTE**

The left rear bearing has no oil holes.

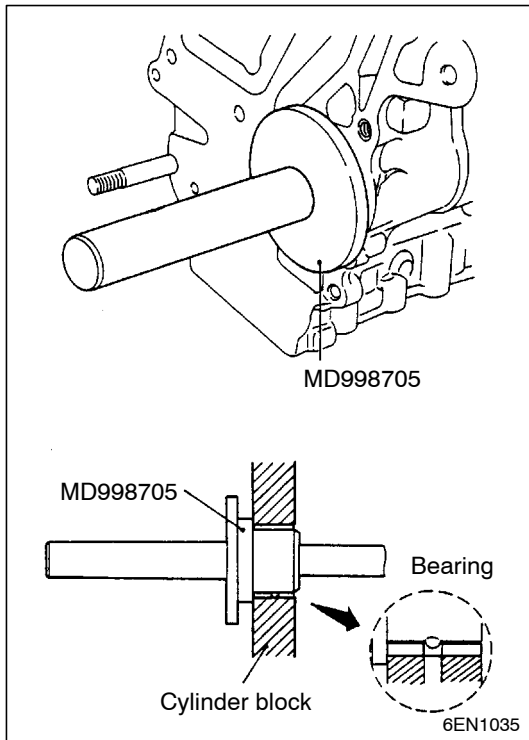

**▶C◀ COUNTERBALANCE SHAFT FRONT BEARING INSTALLATION**

- (1) Using special tools, install front bearing.

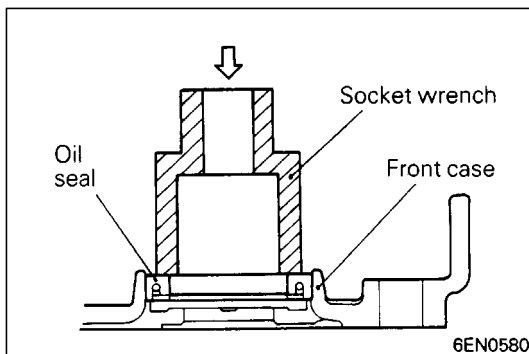

**▶D◀ COUNTERBALANCE SHAFT OIL SEAL INSTALLATION**

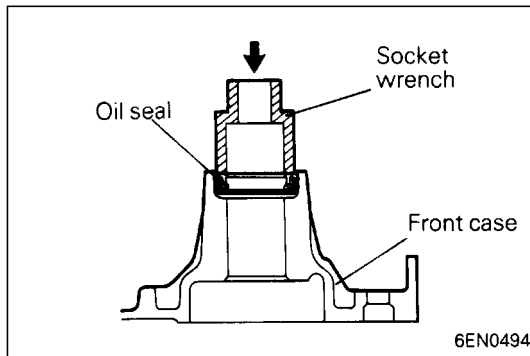

►E◄ OIL PUMP OIL SEAL INSTALLATION

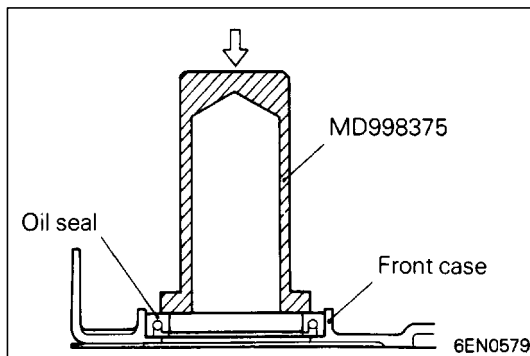

►F◄ CRANKSHAFT FRONT OIL SEAL INSTALLATION

- (1) Using the special tool, install the crankshaft front oil seal into the front case.

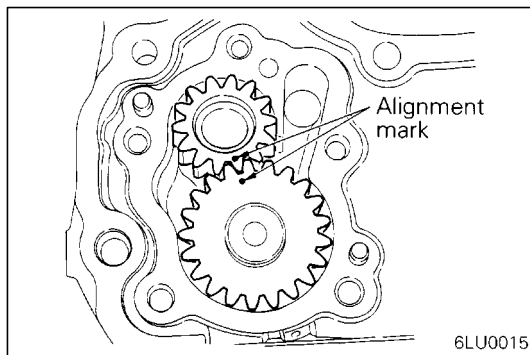

►G◄ OIL PUMP DRIVEN GEAR / OIL PUMP DRIVE GEAR INSTALLATION

- (1) Apply engine oil to the gears and line up the alignment marks.

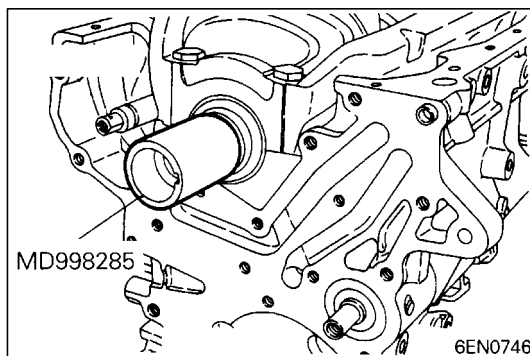

►H◄ FRONT CASE ASSEMBLY INSTALLATION

- (1) Set the special tool on the front end of crankshaft and apply a thin coat of engine oil to the outer circumference of the special tool to install the front case.

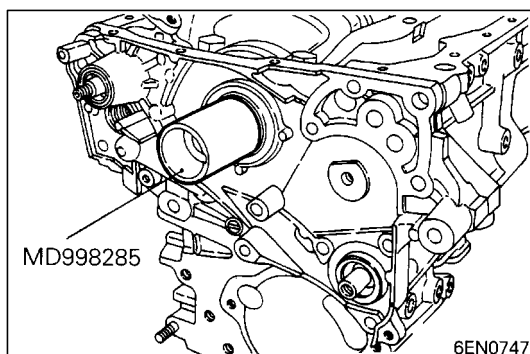

- (2) Install the front case assembly through a new front case gasket and temporarily tighten the flange bolts (other than those for tightening the filter bracket).



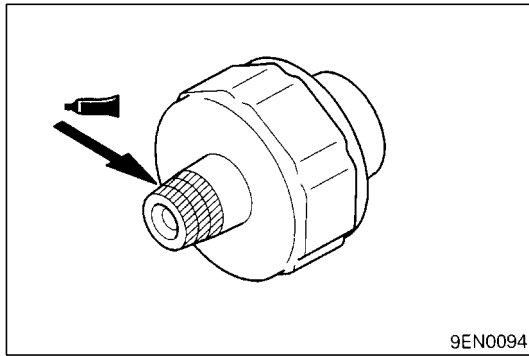

►I◄ **SEALANT APPLICATION TO OIL PRESSURE SWITCH**

- (1) Coat the threads of switch with sealant and install the switch using the special tool.

**Specified sealant: 3M ATD Part No. 8660 or equivalent**

**Caution**

- Keep the end of the thread portion clear of sealant.
- Avoid an overtightening.

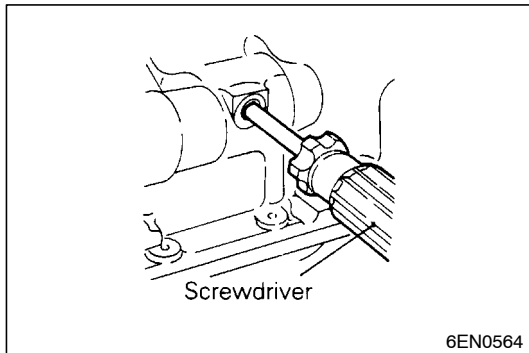

►J◄ **FLANGE BOLT INSTALLATION**

- (1) Insert a Phillips screwdriver into a hole in the left side of the cylinder block to lock the silent shaft.

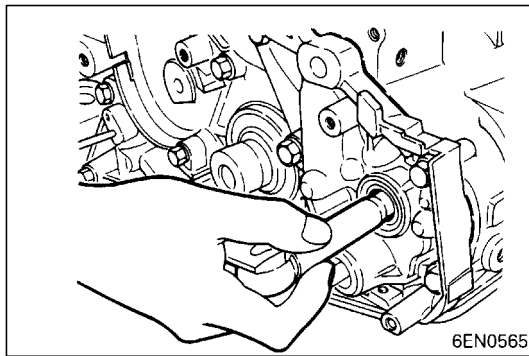

- (2) Secure the oil pump driven gear onto the left counterbalance shaft by tightening the flange bolt to specified torque.

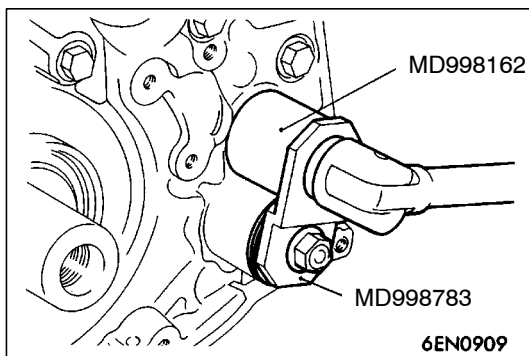

►K◄ **PLUG INSTALLATION**

- (1) Install a new O-ring to the groove of front case.
- (2) Using the special tool, install the plug and tighten to specified torque.

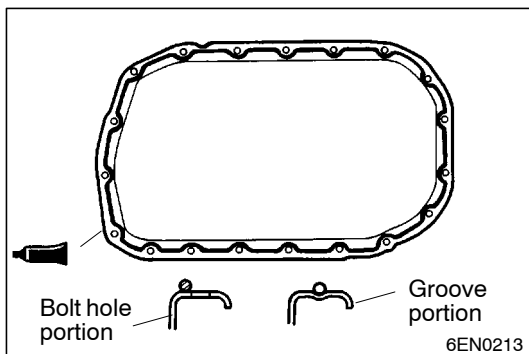

►L◄ **OIL PAN INSTALLATION**

- (1) Clean both mating surfaces of oil pan and cylinder block.
- (2) Apply a 4 mm wide bead of sealant to the entire circumference of the oil pan flange.

**Specified sealant:**

**Mitsubishi Genuine Part No. MD970389 or equivalent**

NOTE

- (1) Be sure to install the oil pan quickly while the sealant is wet (within 15 minutes).
- (2) After installation, keep the sealed area away from the oil and coolant for approx. one hour.

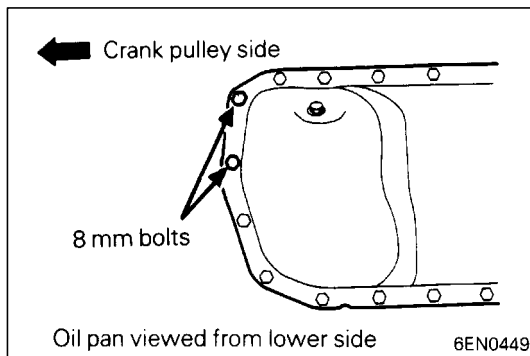

- (3) Note the difference in bolt lengths at the location shown.

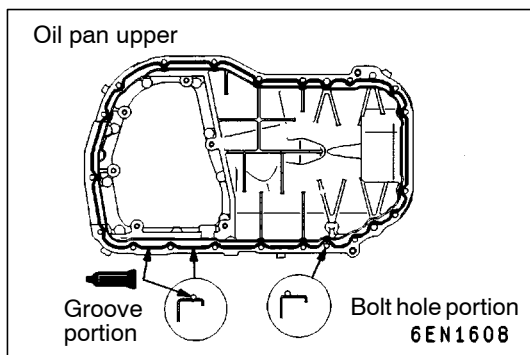

►M◀ OIL PAN UPPER / OIL PAN LOWER INSTALLATION

- (1) Clean both mating surfaces of oil pan and cylinder block.
- (2) Apply a 4 mm wide bead of sealant to the entire circumference of the oil pan upper flange.

Specified sealant:

**Mitsubishi Genuine Part No. MD970389 or equivalent**

NOTE

- (1) Be sure to install the oil pan quickly while the sealant is wet (within 15 minutes).
- (2) After installation, keep the sealant area away from the oil and coolant for approx. one hour.

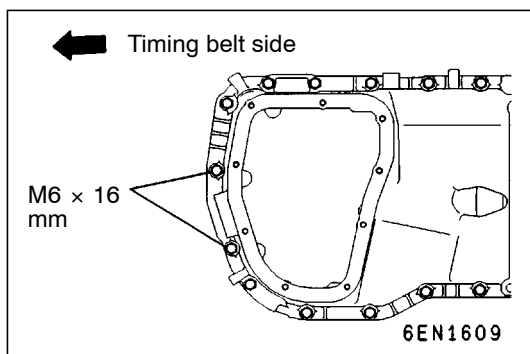

- (3) Note the difference in bolt lengths at the location shown.

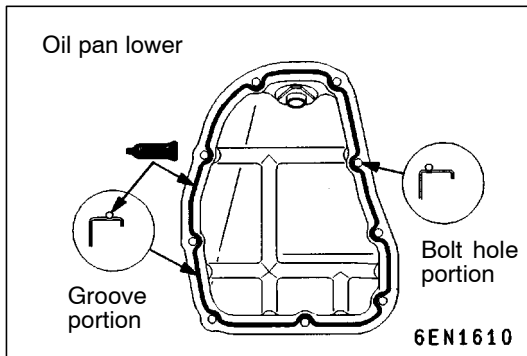

- (4) Clean both mating surfaces of oil pan lower and oil pan upper.
- (5) Apply a 4 mm wide bead of sealant to the entire circumference of the oil pan lower flange.

**Specified sealant:**

**Mitsubishi Genuine Part No. MD970389 or equivalent**

**NOTE**

- (1) Be sure to install the oil pan quickly while the sealant is wet (within 15 minutes).
- (2) After installation, keep the sealant area away from the oil and coolant for approx. one hour.

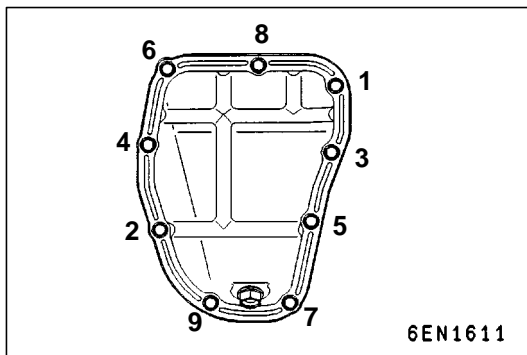

- (6) Tighten the oil pan lower mounting bolts in the sequence shown in the illustration.

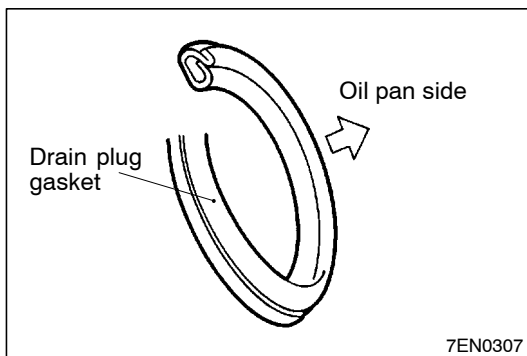

**►◄ DRAIN PLUG GASKET INSTALLATION**

- (1) Install the drain plug gasket in the shown direction.

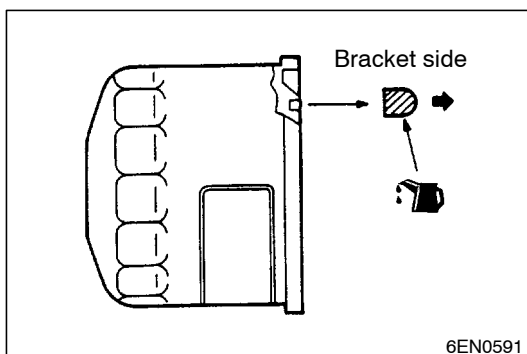

**►◄ OIL FILTER INSTALLATION**

- (1) Clean the installation surface of the filter bracket.
- (2) Apply engine oil to the O-ring of the oil filter.
- (3) Screw the oil filter in until the O-ring contacts the bracket. Then tighten 3/4 turn (tightening torque: 16 Nm).

**NOTE**

For the oil filter MD135737, tighten one turn (Tightening torque: 14 Nm) after the O-ring contacts the bracket.

## INSPECTION

### FRONT CASE

- (1) Check oil holes for clogging and clean if necessary.
- (2) Check the left counterbalance shaft front bearing section for wear, damage and seizure. If there is anything wrong with the section, replace the front case.
- (3) Check the front case for cracks and other damage. Replace cracked or damaged front case.

### OIL SEAL

- (1) Check the oil seal lip for wear and damage. Replace oil seal if necessary.
- (2) Check the oil seal lip for deterioration. Replace oil seal if necessary.

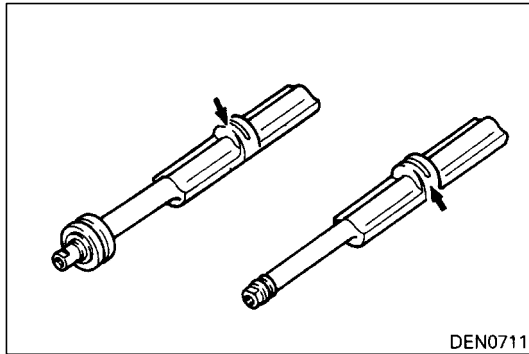

### COUNTERBALANCE SHAFT

- (1) Check oil holes for clogging.
- (2) Check journals for seizure, damage and contact with bearing. If there is anything wrong with the journal, replace the counterbalance shaft, bearing or front case assembly.

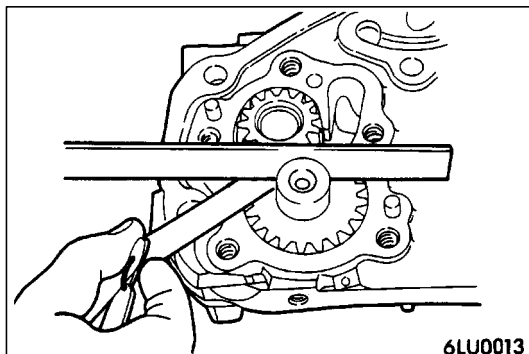

### OIL PUMP

- (1) Assemble the oil pump gear to the front case and rotate it to ensure smooth rotation with no looseness.
- (2) Ensure that there is no ridge wear on the contact surface between the front case and the gear surface of the oil pump cover.
- (3) Check the side clearance.

#### Standard value:

Drive gear	0.08 - 0.14 mm
Driven gear	0.06 - 0.12 mm

# 11. PISTON AND CONNECTING ROD

## REMOVAL AND INSTALLATION

 Apply engine oil to all moving parts before installation.

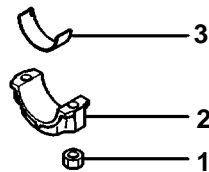
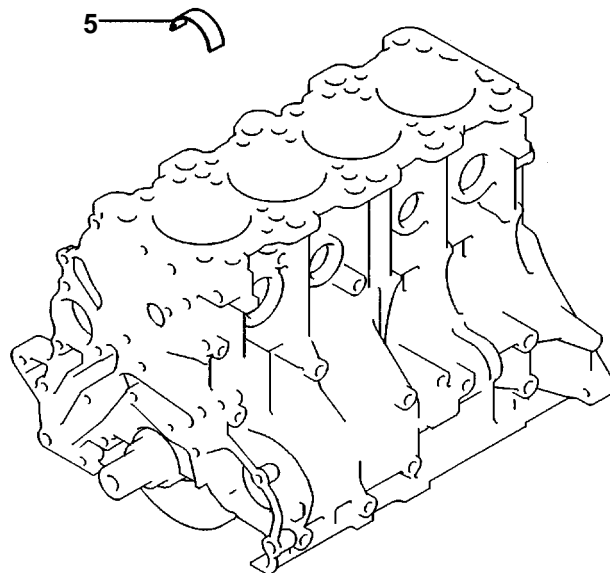
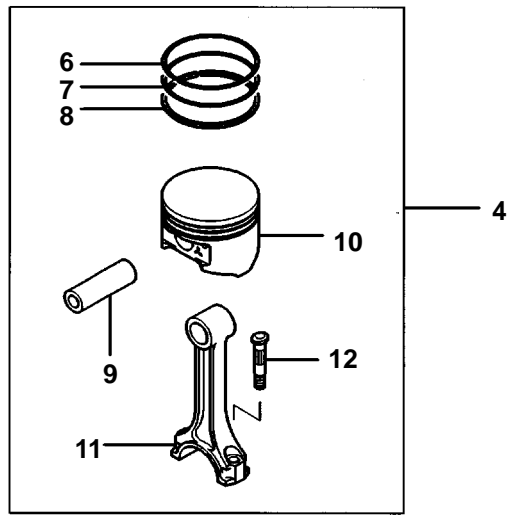

6EN0526

### Removal steps

- A** **G** 1. Nut
- F** 2. Connecting rod cap
- E** 3. Connecting rod bearing
- D** 4. Piston and connecting rod assembly
- E** 5. Connecting rod bearing
- C** 6. Piston ring No. 1

- C** 7. Piston ring No. 2
- B** 8. Oil ring
- A** 9. Piston pin
- 10. Piston
- 11. Connecting rod
- 12. Bolt

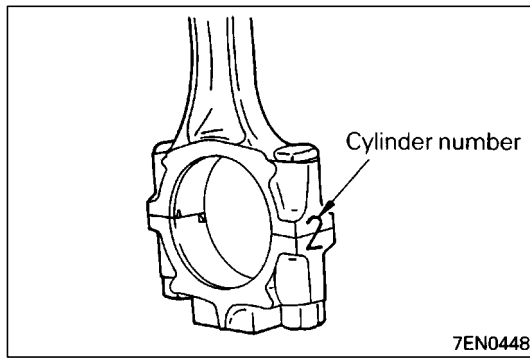

## REMOVAL SERVICE POINTS

### ◀A▶ CONNECTING ROD CAP REMOVAL

- (1) Mark the cylinder number on the side of the connecting rod big end for correct reassembly.
- (2) Keep the removed connecting rods, caps, and bearings in order according to the cylinder number.

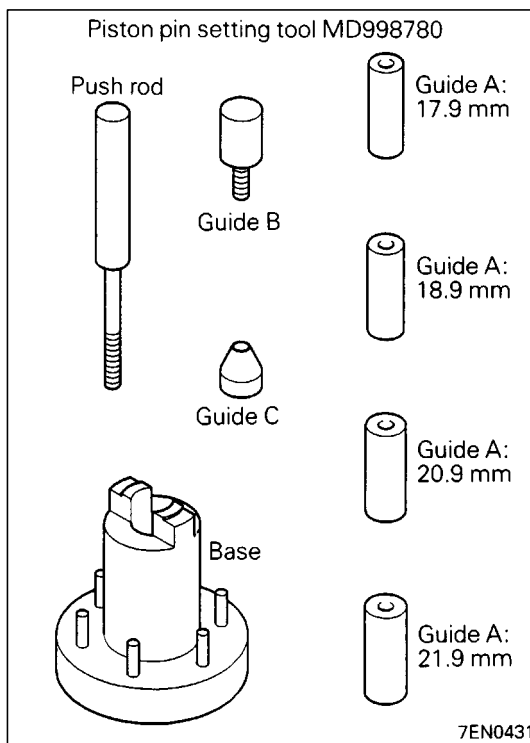

### ◀B▶ PISTON PIN REMOVAL

- (1) Insert the special tool, Push Rod, into the piston from the side on which the front mark is stamped in the piston head, and attach the guide C to the push rod end.
- (2) Place the piston and connecting rod assembly on the special tool, Piston Pin Setting Base, with the front mark facing upward.
- (3) Using a press, remove the piston pin.

#### NOTE

Keep the disassembled pistons, piston pins and connecting rods in order according to the cylinder number.

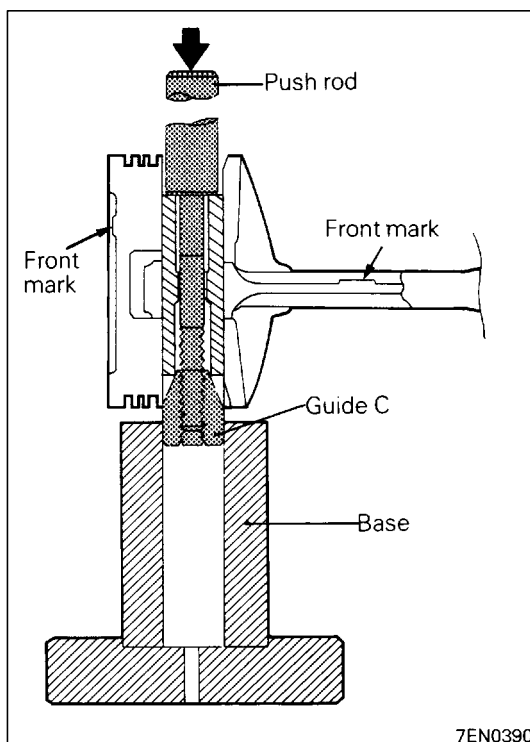

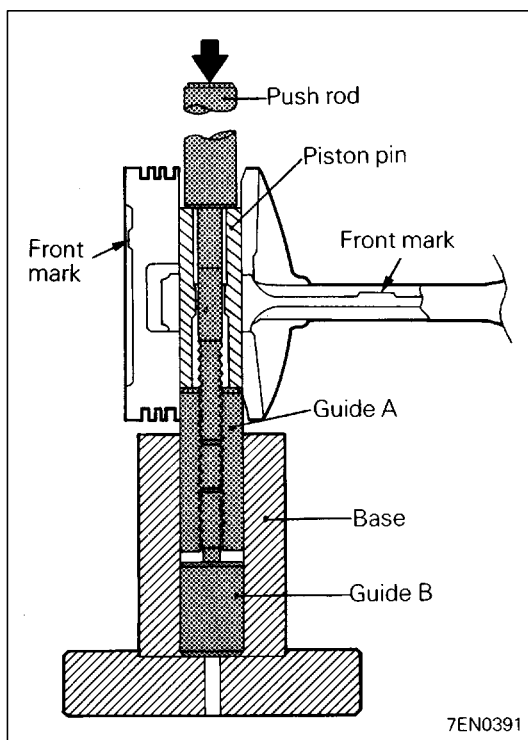
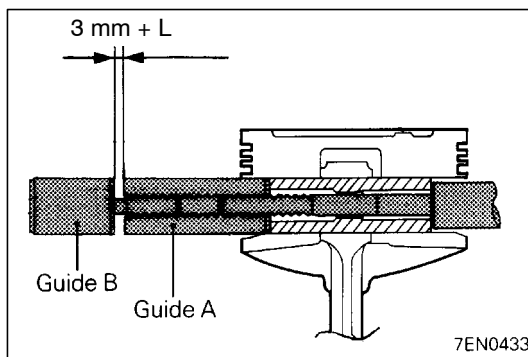
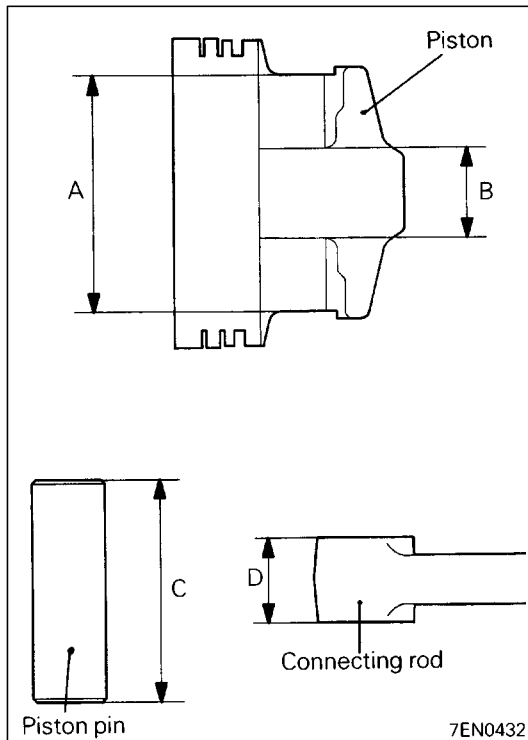

## INSTALLATION SERVICE POINTS

### ▶A◀ PISTON PIN INSTALLATION

- (1) Measure the following dimensions of the piston, piston pin and connecting rod.

A: Piston pin insertion hole length

B: Distance between piston bosses

C: Piston pin length

D: Connecting rod small end width

- (2) Obtain dimension L (to be used later) from the above measurements by using by following formula.

$$L = \frac{(A - C) - (B - D)}{2}$$

- (3) Insert the special tool, Push Rod, into the piston pin and attach the guide A to the push rod end.
- (4) Assemble the connecting rod in the piston with their front marks facing the same direction.
- (5) Apply engine oil to the entire periphery of the piston pin.
- (6) Insert the piston pin, push rod and guide A assembly having assembled in step (3) from the guide A side into the piston pin hole on the front marked side.

- (7) Screw the guide B into the guide A until the gap between both guides amounts to the value L obtained in step (2) plus 3 mm.

- (8) Place the piston and connecting rod assembly onto the piston setting base with the front marks directed upward.

- (9) Press-fit the piston pin using a press.  
If the press-fitting force required is less than the standard value, replace the piston and piston pin set or/and the connecting rod.

**Standard value: 7,350 - 17,200 N**

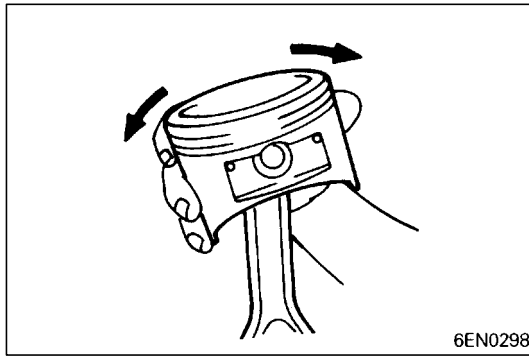

(10) Check that the piston moves smoothly

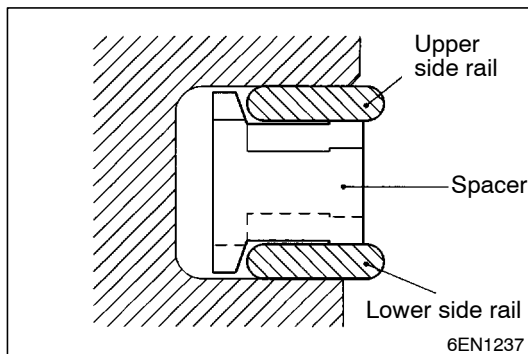

### ▶B◀ OIL RING INSTALLATION

(1) Fit the oil ring spacer into the piston ring groove.

#### NOTE

1. The side rails and spacer may be installed in either direction.
2. New spacers and side rails are colored for identification of their sizes.

Size	Identification color
Standard	None
0.50 mm oversize	Red
1.00 mm oversize	Yellow

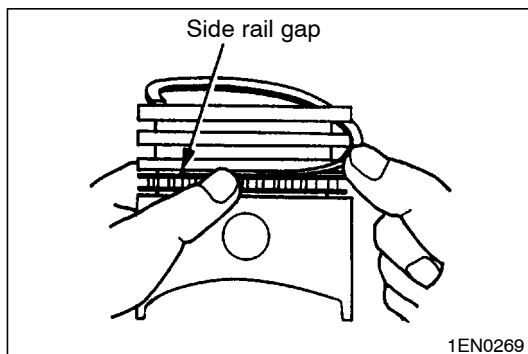

(2) Install the upper side rail.

To install the side rail, first fit one end of the rail into the piston groove, then press the remaining portion into position by finger. See illustration.

Use of ring expander to expand the side rail end gap can break the side rail, unlike other piston rings.

#### Caution

- Do not use piston ring expander when installing side rail.

(3) Install the lower side rail in the same procedure as described in step (2).

(4) Make sure that the side rails move smoothly in either direction.



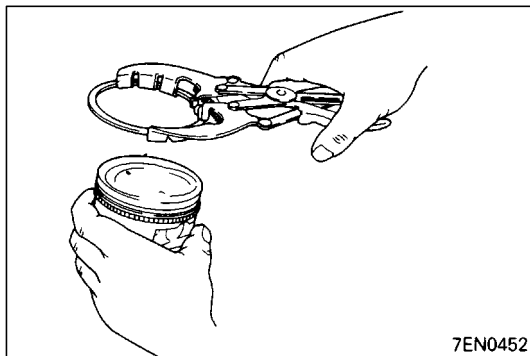

**▶C◀ PISTON RING NO. 2 / PISTON RING NO. 1 INSTALLATION**

- (1) Using piston ring expander, fit No. 2 and then No. 1 piston ring into position.

**NOTE**

1. The ring end is provided with identification mark.

Item		Identification mark
No. 1 ring	4G63 SOHC	1R
	4G64 GDI	T
No. 2 ring	4G63 SOHC	2R
	4G64 GDI	2T

2. Install piston rings with identification mark facing up, to the piston crown side.
3. Size marks on position rings are as follows.

Size	Size mark
Standard	None
0.50 mm oversize	50
1.00 mm oversize	100

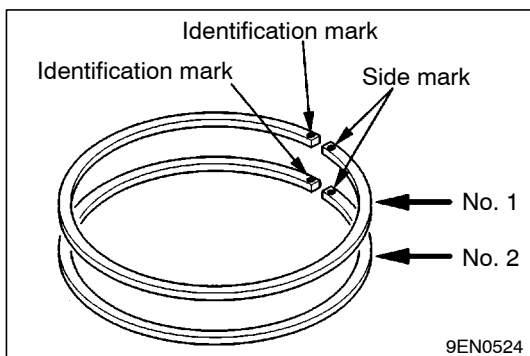

**▶D◀ PISTON AND CONNECTING ROD ASSEMBLY INSTALLATION**

- (1) Liberally coat engine oil on the circumference of the piston, piston ring, and oil ring.
- (2) Arrange the piston ring and oil ring gaps (side rail and spacer) as shown in the figure.
- (3) Rotate the crankshaft so that crank pin is on the center of cylinder bore.

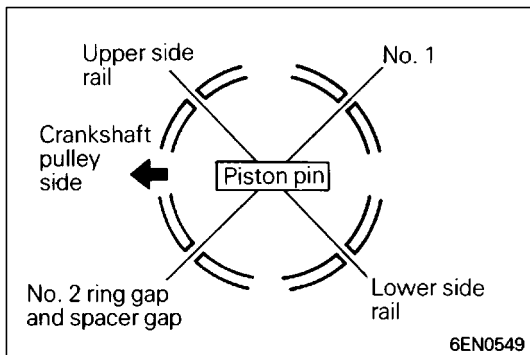

- (4) Use suitable thread protectors on the connecting rod bolts before inserting piston and connecting rod assembly into the cylinder block.  
Care must be taken not to nick the crank pin.
- (5) Using a suitable piston ring compressor tool, install the piston and connecting rod assembly into the cylinder block.

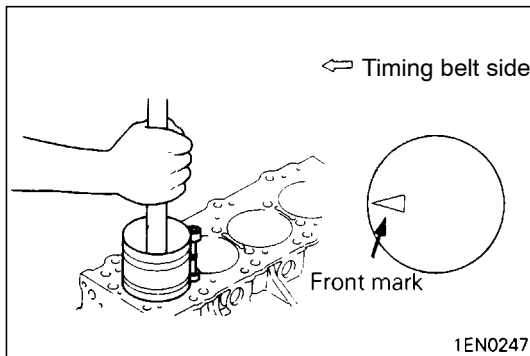

**▶E◀ CONNECTING ROD BEARINGS INSTALLATION**

When the bearing needs replacing, select and install a proper bearing by the following procedure.

- (1) Measure the crankshaft pin diameter and confirm its classification from the following table. In the case of a crankshaft supplied as a service part, identification colors of its pins are painted at the positions shown in the illustration.

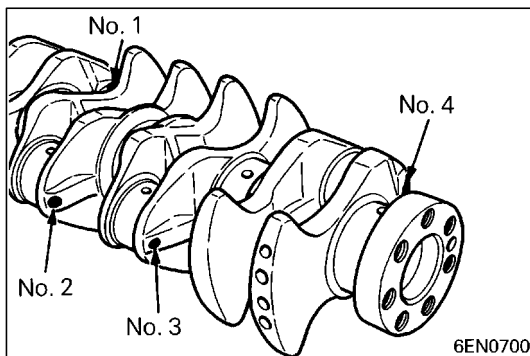

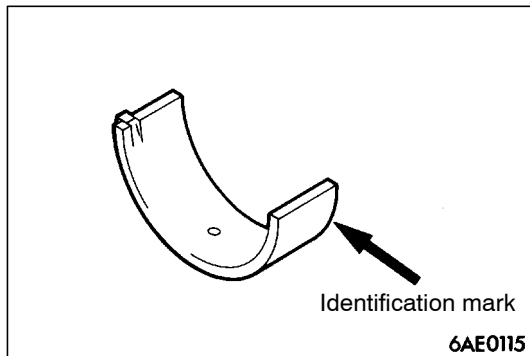

- (2) The connecting rod bearing identification mark is stamped at the position shown in the illustration.

Crankshaft pin				Connecting rod bearing	
Classification	Identification mark	Identification color	O. D. mm	Identification mark	Thickness mm
	Production part	Service part			
1	None	Yellow	44.995 - 45.000	1	1.478 - 1.491
2	None	None	44.985 - 44.995	2	1.491 - 1.495
3	None	White	44.980 - 44.985	3	1.495 - 1.499

### Connecting rod I.D.: 48.000 - 48.015 mm

- (3) Select a proper bearing from the above table on the basis of the identification data confirmed under items (1) and (2).

#### [Example]

If the measured value of a crankshaft pin outer diameter is 44.996 mm, the pin is classified as "1" in the table. In case the crankshaft is also replaced by a spare part, check the identification colors of the pins painted on the new crankshaft. If the color is yellow, for example, the pin is classified as "1". In the above cases, select the connection rod bearing having identification mark "1".

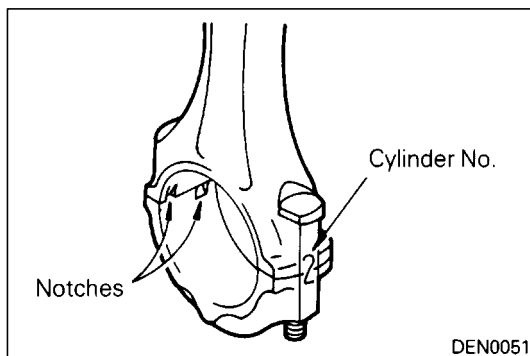

### ►F◄ CONNECTING ROD CAP NUT INSTALLATION

- (1) Verifying the mark made during disassembly, install the bearing cap to the connecting rod. If the connecting rod is new with no index mark, make sure that the bearing locking notches come on the same side as shown.

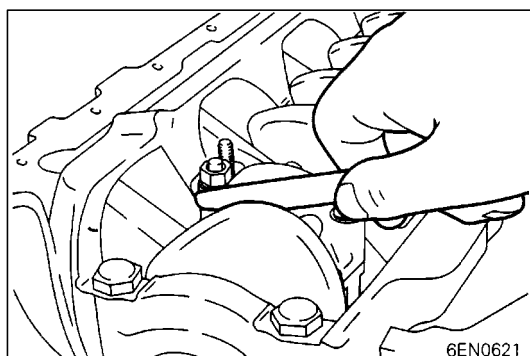

- (2) Make sure that the connecting rod big end side clearance meets the specification.

**Standard value: 0.10 - 0.25 mm**

**Limit: 0.4 mm**

## ▶G◀CONNECTING ROD CAP NUT INSTALLATION

### Caution

- If the cylinder head has been installed before installing the connecting rod cap nut, be sure to remove the spark plugs.

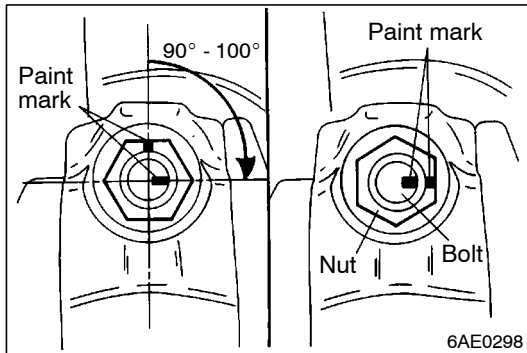

- (1) Since the connecting rod cap bolts and nuts are torqued using the plastic area tightening method, the bolts should be examined BEFORE reuse. If the bolt threads are “necked down”, the bolt should be replaced. Necking can be checked by running a nut with fingers to the full length of the bolt threads. If the nut does not run down smoothly, the bolt should be replaced.
- (2) Before installation of each nut, apply engine oil to the thread portion and bearing surface of the nut.
- (3) Install each nut to the bolt and tighten it with fingers. Then tighten the nuts alternately to install the cap properly.
- (4) Tighten the nuts to a torque of 20 Nm.
- (5) Make a paint mark on the head of each nut.
- (6) Make a paint mark on the bolt end at the position 90° to 100° from the paint mark made on the nut in the direction of tightening the nut.
- (7) Give a 90° to 100° turn to the nut and make sure that the paint mark on the nut and that on the bolt are in alignment.

### Caution

- If the nut is turned less than 90°, proper fastening performance may not be expected. When tightening the nut, therefore, be careful to give a sufficient turn to it.
- If the nut is overtightened (exceeding 100°), loosen the nut completely and then retighten it by repeating the tightening procedure from step (1).

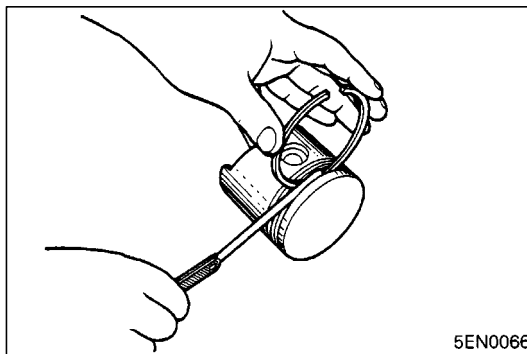

## INSPECTION

### PISTON RING

- (1) Check the piston ring for damage, excessive wear, and breakage and replace if defects are evident. If the piston has been replaced with a new one, the piston rings must also be replaced with new ones.
- (2) Check for the clearance between the piston ring and ring groove. If the limit is exceeded, replace the ring or piston, or both.

**Standard value: 0.02 - 0.06 mm**

**Limit: 0.1 mm**

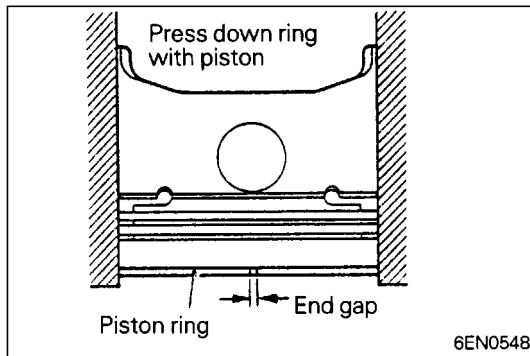

- (3) Install the piston ring into the cylinder bore. Force it down with a piston, its crown being in contact with the ring, to correctly position it at right angles to the cylinder wall. Then, measure the end gap with a feeler gauge. If the ring gap is excessive, replace the piston ring.

**Standard value:**

No. 1 ring	0.25 - 0.35 mm
No. 2 ring	0.40 - 0.55 mm
Oil ring	0.10 - 0.40 mm

**Limit:**

No. 1, No. 2 ring	0.8 mm
Oil ring	1.0 mm

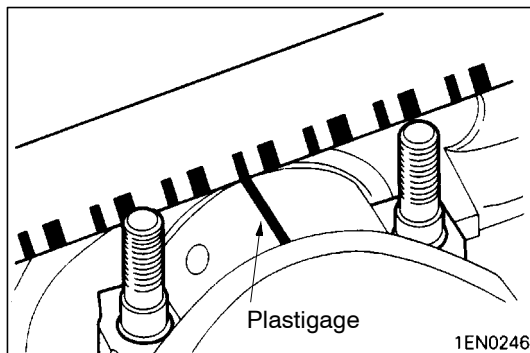

**CRANKSHAFT PIN OIL CLEARANCE  
(PLASTIGAGE METHOD)**

- (1) Remove oil from the crankshaft pin and connecting rod bearing.  
 (2) Cut the Plastigage to the same length as the width of the bearing and place it on the crankshaft pin in parallel with its axis.

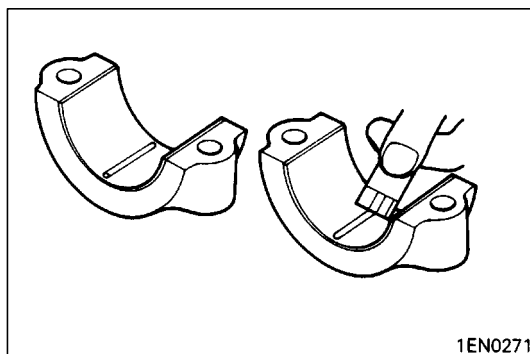

- (3) Install the connecting rod cap carefully and tighten the nuts to specified torque.  
 (4) Carefully remove the connecting rod cap.  
 (5) Measure the width of the Plastigage at its widest part by using a scale printed on the Plastigage package.

**Standard value: 0.02 - 0.05 mm**

**Limit: 0.1 mm**

# 12. CRANKSHAFT, FLYWHEEL AND DRIVE PLATE

## REMOVAL AND INSTALLATION

Apply engine oil to all moving parts before installation.

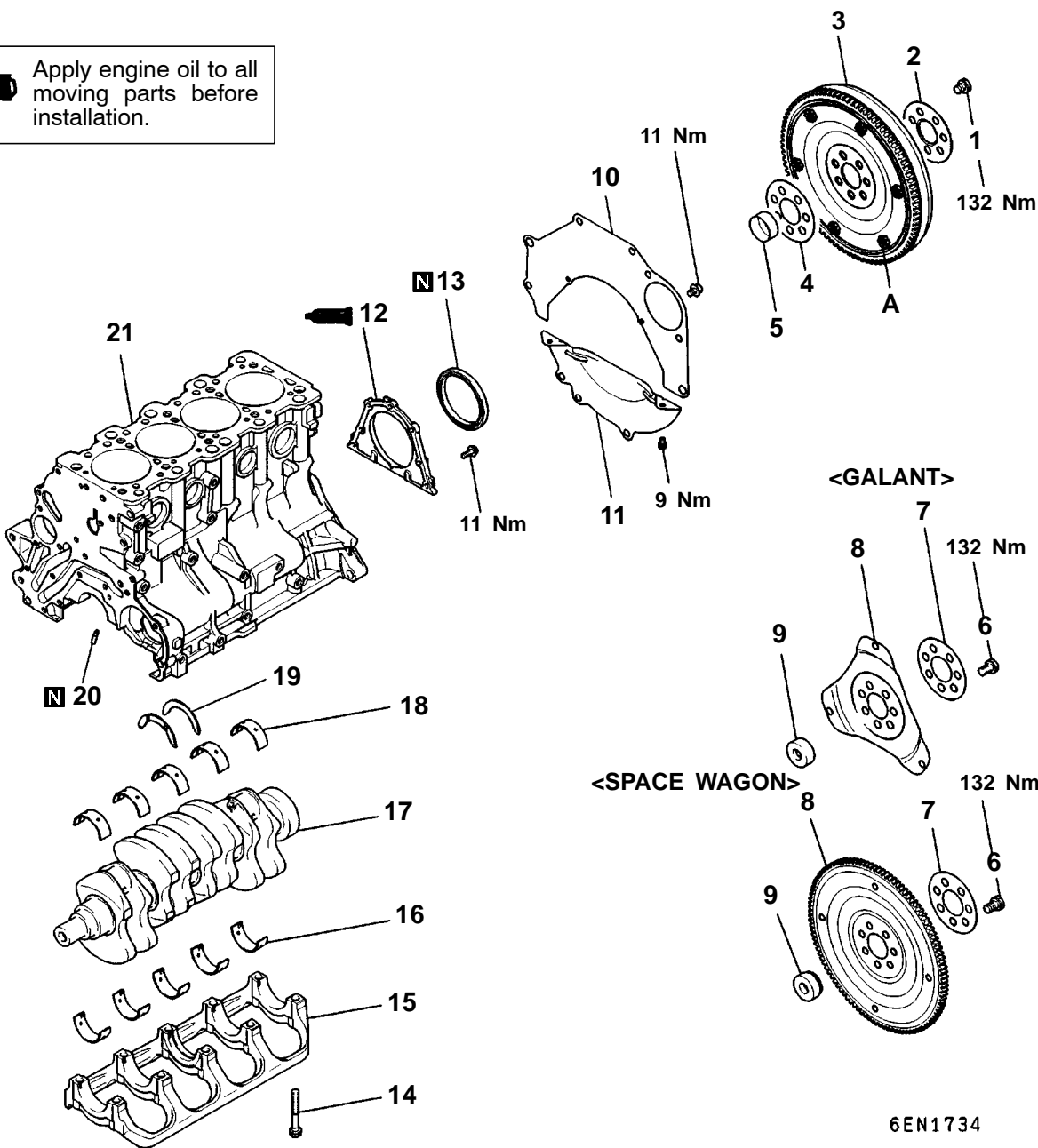

### Removal steps

1. Flywheel bolt <M/T>
2. Adapter plate <M/T>
3. Flexible flywheel <M/T>
4. Adapter plate <M/T>
5. Crankshaft bushing <M/T>
6. Drive plate bolt <A/T>
7. Adapter plate <A/T>
8. Drive plate <A/T>
9. Crankshaft bushing <A/T>
10. Rear plate
11. Bell housing cover

- ▶▶F◀◀ 12. Oil seal case
- ▶▶E◀◀ 13. Oil seal
- ▶▶D◀◀ 14. Bearing cap bolt
- ▶▶D◀◀ 15. Bearing cap
- ▶▶C◀◀ 16. Crankshaft bearing, lower

- ▶▶C◀◀ 17. Crankshaft
- ▶▶B◀◀ 18. Crankshaft bearing, upper
- ▶▶A◀◀ 19. Crankshaft thrust bearing <GDI engine>
- ▶▶A◀◀ 20. Oil jet <GDI engine>
- ▶▶A◀◀ 21. Cylinder block

### Caution

On the flexible wheel equipped engines, do not remove any of the bolts "A" of the flywheel shown in the illustration.

The balance of the flexible flywheel is adjusted in an assembled condition. Removing the bolt, therefore, can cause the flexible flywheel to be out of balance, giving damage to the flywheel.

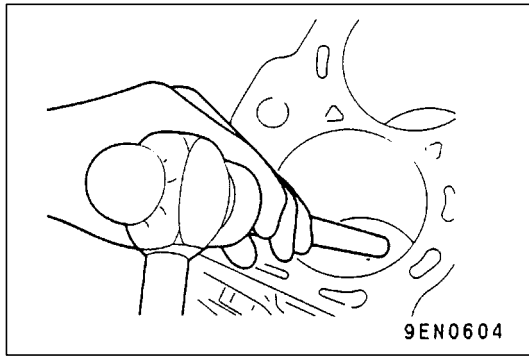

## REMOVAL SERVICE POINT

### ◀A▶ OIL JET REMOVAL

- (1) Knock out the oil jets using an appropriate metal rod.

#### Caution

- Be careful not to scratch the cylinder wall.
- Do not reuse the removed oil jets.

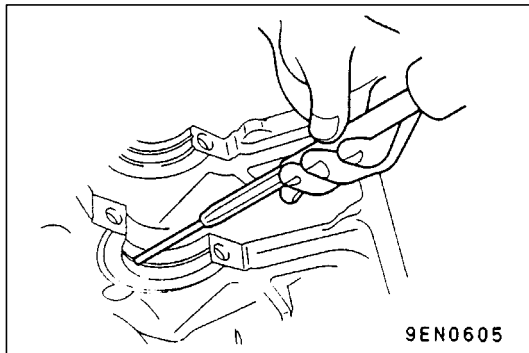

## INSTALLATION SERVICE POINTS

### ▶A◀ OIL JET INSTALLATION

- (1) Using a 4.5 mm diameter pin punch, drive in the oil jet to the crankshaft journal until it seats to the bottom.

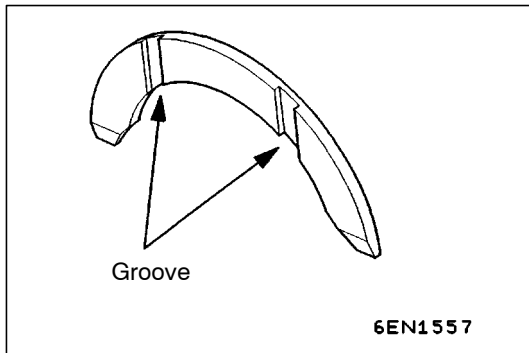

### ▶B◀ CRANKSHAFT THRUST BEARING INSTALLATION

- (1) Install the two thrust bearing in the number 3 bearing bore in the cylinder block. For easier installation, apply engine oil to the bearings; this will help hold them in position.
- (2) The thrust bearings must be installed with their groove side toward the crankshaft web.

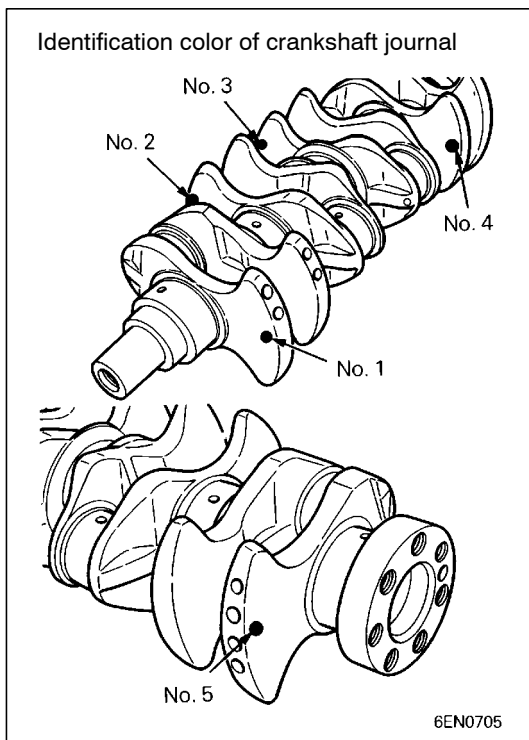

### ▶C◀ CRANKSHAFT BEARING INSTALLATION

- (1) From the following table, select a bearing whose size is appropriate for the crankshaft journal outside diameter.

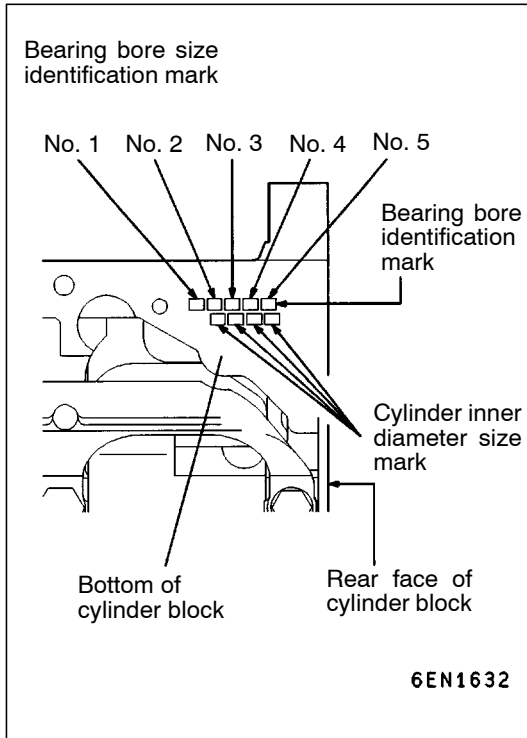

Crankshaft journal outside diameter		Cylinder block bearing bore	Crankshaft bearing	Crankshaft bearing for No. 3
Identification color	Size mm	Identification mark	Identification mark or color	Identification mark or color
Yellow	56.994 - 57.000	0	1 or Green	0 or Black
		1	2 or Yellow	1 or Green
		2	1 or Green	2 or Yellow
None	56.988 - 56.994	0	2 or Yellow	1 or Green
		1	3 or None	2 or Yellow
		2	2 or Yellow	3 or None
White	56.982 - 56.988	0	3 or None	2 or Yellow
		1	4 or Blue	3 or None
		2	5 or Red	4 or Blue

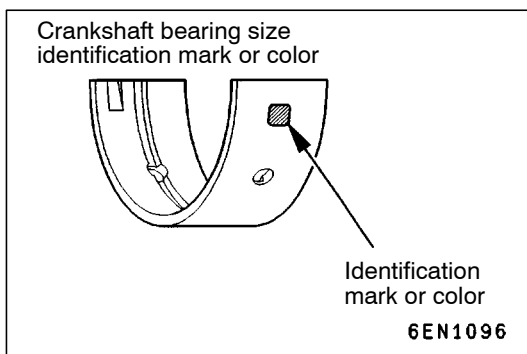

For example, if the crankshaft journal outside diameter ID color is "yellow" and cylinder block bearing bore ID mark is "1", select a bearing whose ID mark is "2" or ID color is "yellow" for number 1, 2, 4 and 5, and a bearing whose ID mark is "1" or ID color is "green" for number 3.

If there is no ID color paint on the crankshaft, measure the journal outside diameter and select a bearing appropriate for the measured value.

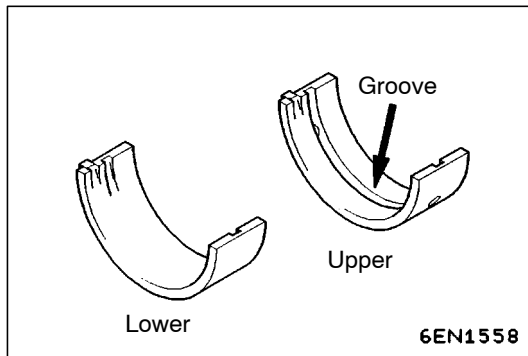

- (2) Install the bearings having an oil groove to the cylinder block.
- (3) Install the bearings having no oil groove to the bearing cap.

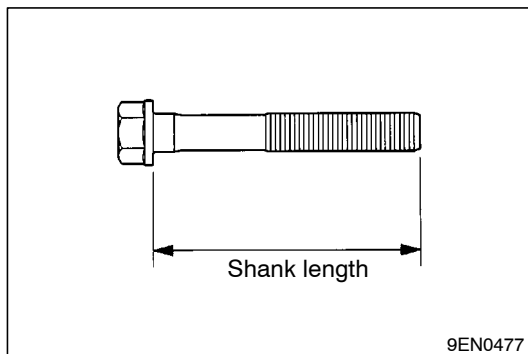

## ▶◀ BEARING CAP / BEARING CAP BOLT INSTALLATION

- (1) Install the bearing caps so the arrow points to the timing belt side.
- (2) Before installing the bearing cap bolts, check that the shank length of each bolt meets the limit. If the limit is exceeded, replace the bolt.

**Limit: Max. 71.1 mm**

- (3) Apply engine oil to the threaded portion and bearing surface of the bolt.
- (4) Tighten the bolts to 25 Nm in the specified tightening sequence.

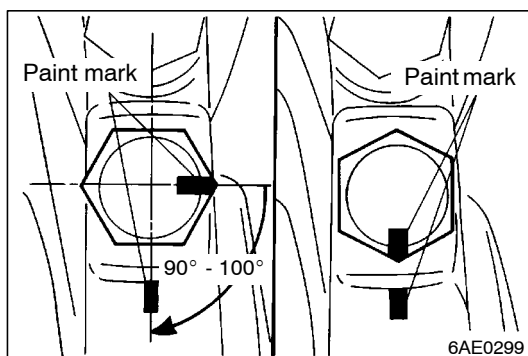
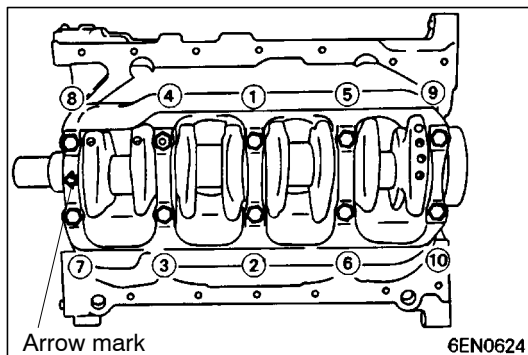

- (5) Make a paint mark on the head of each bolt.
- (6) Make a paint mark on the bearing cap at the position 90° to 100° from the paint mark made on the bolt in the direction of tightening the bolt.
- (7) According to the specified tightening sequence, give a 90° to 100° turn to each bolt and make sure that the paint mark on the bolt and that on the cap are in alignment.

### Caution

- If the bolt is turned less than 90°, proper fastening performance may not be expected. When tightening the bolt, therefore, be careful to give a sufficient turn to it.
- If the bolt is overtightened (exceeding 100°), loosen the bolt completely and then retighten it by repeating the tightening procedure from step (1).



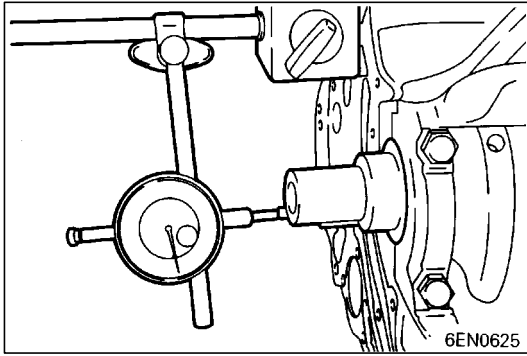

- (8) After installing the bearing caps, make sure that the crankshaft turns smoothly and the end play is correct. If the end play exceeds the limit, replace No. 3 crankshaft bearings.

**Standard value: 0.05 - 0.18 mm**

**Limit: 0.25 mm**

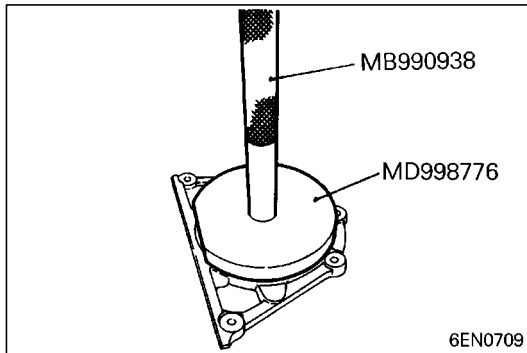

### ►E◄ OIL SEAL INSTALLATION

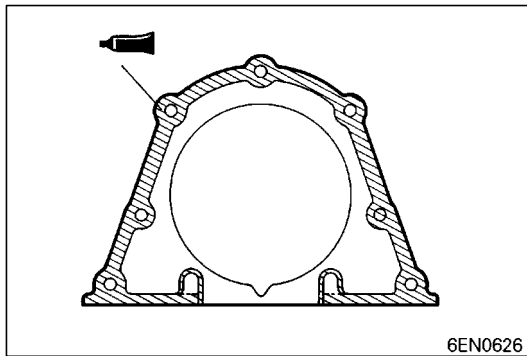

### ►F◄ SEALANT APPLICATION TO OIL SEAL CASE

**Specified sealant:**

**Mitsubishi Genuine Part No. MD970389 or equivalent**

**NOTE**

- (1) Be sure to install the case quickly while the sealant is wet (within 15 minutes).
- (2) After installation, keep the sealed area away from the oil and coolant for approx. one hour.

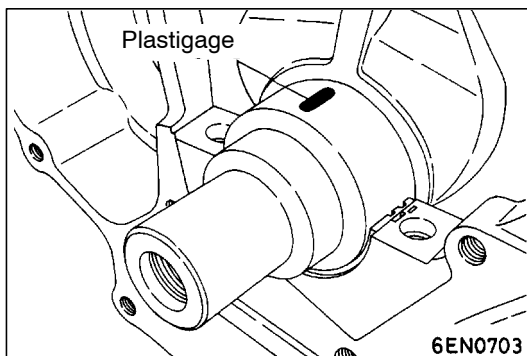

### INSPECTION

#### CRANKSHAFT OIL CLEARANCE (PLASTIGAGE METHOD)

- (1) Remove oil from the crankshaft journal and the crankshaft bearing.
- (2) Install the crankshaft.
- (3) Cut the Plastigage to the same length as the width of the bearing and place it on the journal in parallel with its axis.
- (4) Install the crankshaft bearing cap carefully and tighten the bolts to the specified torque.
- (5) Carefully remove the crankshaft bearing cap.
- (6) Measure the width of the Plastigage at its widest part by using a scale printed on the Plastigage package.

**Standard value: 0.02 - 0.04 mm**

**Limit: 0.1 mm**

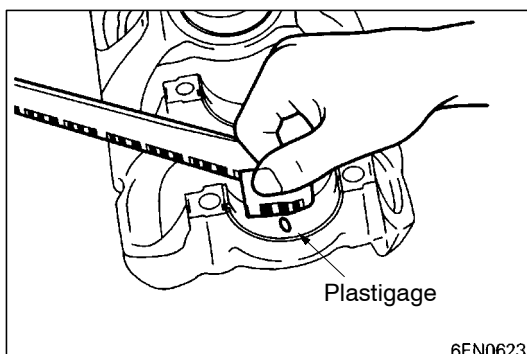

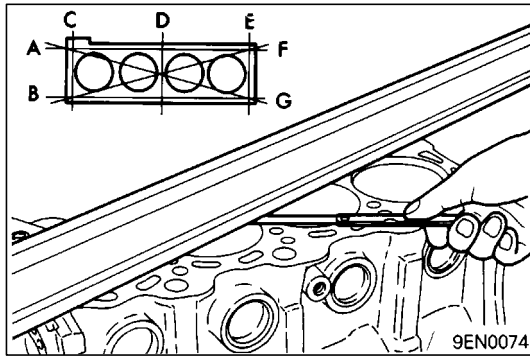

### CYLINDER BLOCK

- (1) Visually check for scratches, rust, and corrosion. Use also a flaw detecting agent for the check. If defects are evident, correct, or replace.
- (2) Using a straightedge and feeler gauge, check the block top surface for warpage. Make sure that the surface is free from gasket chips and other foreign matter.

**Standard value: 0.05 mm**

**Limit: 0.1 mm**

- (3) If the distortion is excessive, correct within the allowable limit or replace.

**Grinding limit: 0.2 mm**

**Includes/combined with cylinder head grinding**

**Cylinder block height (when new):**

**4G63 284 mm**

**4G64 290 mm**

- (4) Check cylinder walls for scratches and seizure. If defects are evident, correct (bored to oversize) or replace.

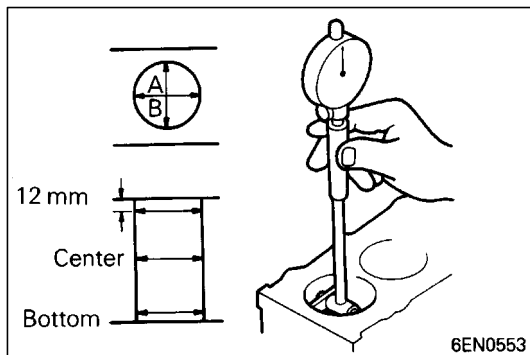

- (5) Using cylinder gauge, measure the cylinder bore and cylindricity. If worn badly, correct cylinder to an oversize and replace piston and piston rings. Measure at the points shown in illustration.

**Standard value:**

**Cylinder I.D.**

**4G63 85.00 - 85.03 mm**

**4G64 86.50 - 86.53 mm**

**Cylindricity 0.01 mm or less**

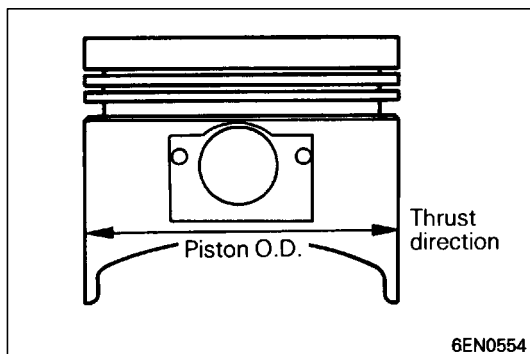

### BORING CYLINDER

- (1) Oversize pistons to be used should be determined on the basis of the largest bore cylinder.

#### Piston size identification

Size	Identification mark
0.50 O.S.	0.50
1.00 O.S.	1.00

#### NOTE

Size mark is stamped on the piston top.

- (2) Measure outside diameter of piston to be used. Measure it in thrust direction as shown.
- (3) Based on the measured piston O.D. calculate boring finish dimension.

**Boring finish dimension = Piston O.D. + (clearance between piston O.D. and cylinder) - 0.02 mm (honing margin)**

- (4) Bore all cylinders to the calculated boring finish dimension.

**Caution**

- To prevent distortion that may result from temperature rise during honing, bore cylinders, working from No. 2, No. 4, No. 1 to No. 3.

- (5) Hone to final finish dimension (piston O.D. + clearance between piston O.D. and cylinder).
- (6) Check clearance between piston and cylinder.

**Clearance between piston and cylinder:**

**0.02 - 0.04 mm**

**NOTE**

When boring cylinders, finish all of four cylinders to same oversize. Do not bore only one cylinder to an oversize.

---

## NOTES