

REPAIR INSTRUCTION

010X0-01

PRECAUTION

1. TO PREVENT FROM ENTERING FOREIGN SUBSTANCES

- (a) When foreign substances such as dust, grain of sand or metallic dust enter inside of engine, it often causes functional failure of the engine.
- (1) Precaution before disassembly.
 - Remove adequately all sand and mud adhere to the outside of engine .
 - (2) Precaution at reassembly.
 - Protect disassembled parts from dust by using vinyl sheet to cover.

2. TO PREVENT SCRATCHES ON THE PARTS

- (a) The existence of scratches on the contact and revolving surfaces often causes oil leak and seizure.
- (1) Precautions at disassembly and reassembly.
 - When disassemble the contact surface of the parts, use plastic hammer striking lightly. (Do not pry out by screwdriver).
 - When fix the parts to the vise, do not directly catch it in the vise. Fix the parts through aluminum bar.

3. TO CLEAN AND WASH THE PARTS

- (a) Each parts needs to be well cleaned, washed, and dried by air, and apply specified oil before reassembly.
- (1) Cleaning and washing by alkaline solvent is prohibited:
 - Parts made of aluminum and rubber. (ex. cylinder head cover gasket etc.)
 - (2) Cleaning and washing by flushing oil (ex. kerosene, white gasoline etc.) is prohibited:
 - Parts made of rubber. (ex. cylinder head cover gasket etc.)

4. POSITION AND DIRECTION OF EACH PARTS

- (a) Each parts needs to be reassembled as the same position and direction as it disassembled.
- (1) Precautions at disassembly and reassembly.
 - Follow the directions when the manual designates to mark the matchmark and/or direction mark.
 - Disassembled parts needs to be put in order as disassembled, not to change position and/or direction.
 - Follow the directions when the manual instructs the position and direction.

5. INSTALL ENGINE ASSEMBLY TO OVERHAUL STAND WHEN OVERHAUL THE ENGINE

6. PUT THE DISASSEMBLED PARTS IN ORDER AS THEY DISASSEMBLED

7. APPLY ENGINE OIL TO THE SLIDING AND ROTATING SURFACES

8. NON-REUSABLE PARTS SUCH AS GASKET AND SEAL NEEDS TO BE CHANGED TO THE NEW PARTS

9. BASIC REPAIR HINT

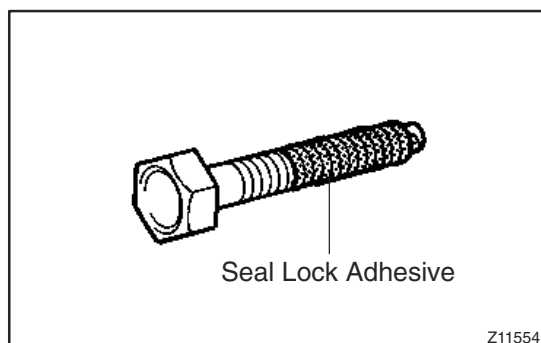

(a) Precoated Parts:

- (1) Precoated parts are bolts, nuts, etc. that are coated with a seal lock adhesive at the factory.
- (2) If a precoated part is retightened, loosened or caused to move in any way, it must be recoated with the specified adhesive.
- (3) When reusing precoated parts, clean off the old adhesive and dry with compressed air. Then apply the specified seal lock adhesive to the bolt, nut or threads.

NOTICE:

Do the torque checking with the lower limit value of the torque tolerance.

- (4) Depending on the seal lock agent to apply, there may be a case where it is necessary to leave it for a specified time until it hardens.
- (b) Gaskets:
When necessary, use a sealer on gaskets to prevent leaks.
- (c) Bolts, Nuts and Screws:
Carefully observe all specifications for bolt tightening torques. Always use a torque wrench.

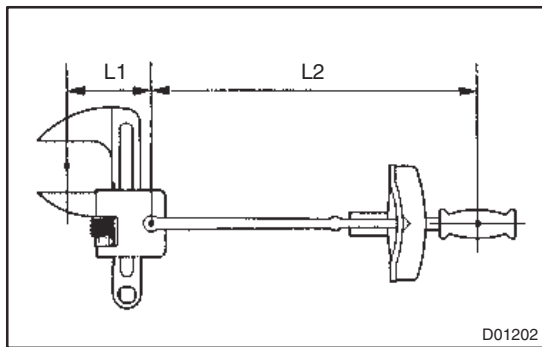
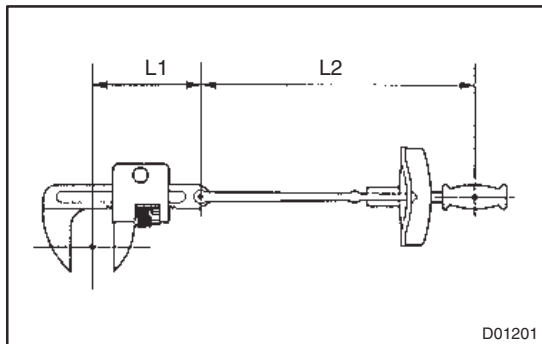
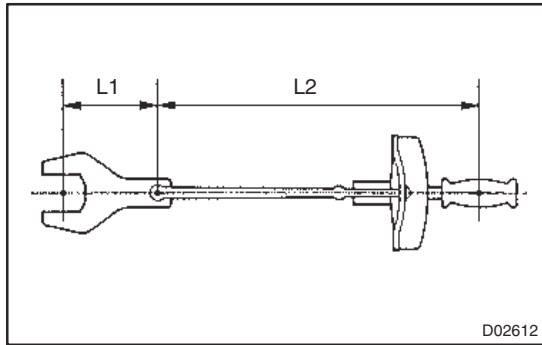

- (d) Torque When Using Extension Tool with Torque Wrench:
 - (1) In case of tightening by extending the entire length of the torque wrench combined with SST or tool, if you tighten until the reading of the torque wrench reached the specified torque value, the actual torque becomes excessive.
 - (2) In this text, only the specified torque is described. In case of using SST or extension tool, find the reading of the torque wrench by the formula.
 - (3) Formula $T' = T \times L2 / (L1 + L2)$

T'	Reading of torque wrench {N·m (kgf·cm, ft·lbf)}
T	Torque {N·m (kgf·cm, ft·lbf)}
L1	Length of SST or tool (cm)
L2	Length of torque wrench (cm)

10. REMOVAL AND INSTALLATION OF FUEL CONTROL PARTS

- (a) Place for Removing and Installing Fuel System Parts:
 - (1) Place with good air ventilation and without anything flammable such as welder, grinder, drill, electric motor or stove in the surroundings.
 - (2) Never work in a place like a pit or nearby pit as there is a possibility that vaporized fuel fills those places.
- (b) Removing and Installing of Fuel System Parts:
 - (1) Prepare a fire extinguisher before starting the operation.
 - (2) For prevention of the static electricity, install a ground on the fuel changer, vehicle and fuel tank, and do not spray much water so as to prevent slipping.

- (3) Never use any electric equipment like an electric motor or a working light as they may cause spark or high temperature.
- (4) Never use an iron hammer as it may cause spark.
- (5) Dispose the shop rag separately from any fuel deposit.

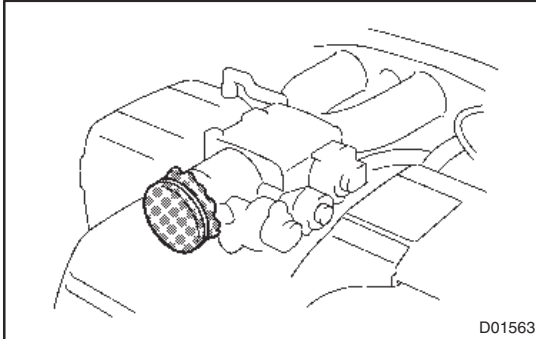

11. REMOVAL AND INSTALLATION OF ENGINE INTAKE PARTS

- (a) If any metal tip is mixed in the inlet pass, that may give a bad effect to the engine and turbo charger.
- (b) When removing and installing of the inlet system parts, close the opening of the removed inlet system parts and the engine with a clean shop rag or gum tape.
- (c) When installing the inlet system parts, check that there is no mixing of a metal tip.

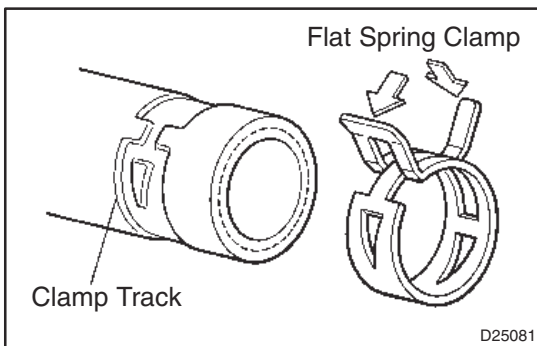

12. HANDLING OF HOSE CLAMPS

- (a) Before removing the hose, check the depth of inserting portion and the clamp position to restore it surely.
- (b) Change a deformed or dented into a new one.
- (c) In case of reusing the hose, install the clamp on the hose where it has a clamp track.
- (d) For a flat spring type clamp, make it adjust by adding force to the arrow mark direction after the installation.