

HOW TO USE THIS ENGINE REPAIR MANUAL (1AZ-FE)

0107M-01

GENERAL INFORMATION

1. GENERAL DESCRIPTION

- (a) This manual is made in accordance with SAE J2008.
- (b) Generally repair operations can be separated in the following 3 main processes:
 1. Diagnosis
 2. Removing and Installing, Replacing, Disassembling, Installing and Checking, Adjusting
 3. Final Inspection
- (c) This manual explains "Removing and Installing, Replacing, Disassembling, Installing and Checking, Adjusting", but "Final Inspection" is omitted.
- (d) The following essential operations are not written in this manual, however these operations must be done in the practical situation.
 - (1) Operation with a jack or lift
 - (2) Cleaning of a removed part when necessary
 - (3) Visual check

2. INDEX

- (a) An alphabetical INDEX is provided as a section on the end of the book to guide you to the item to be repaired.

3. PREPARATION

- (a) Use of special service tools (SST) and special service materials (SSM) may be required, depending on the repairing condition. Be sure to use SST and SSM when they are required and follow the working procedure properly. A list of SST and SSM is in the Preparation section of this manual.

4. REPAIR PROCEDURES

- (a) Component drawing is placed as the section or title when necessary.
- (b) Illustrations of the parts catalog are placed as the "disassembled parts drawing" so that it enables you to understand the fitting condition of the components.
- (c) Non-reusable parts, grease applied parts, precoated parts and tightening torque are specified in the components drawing.

Example:

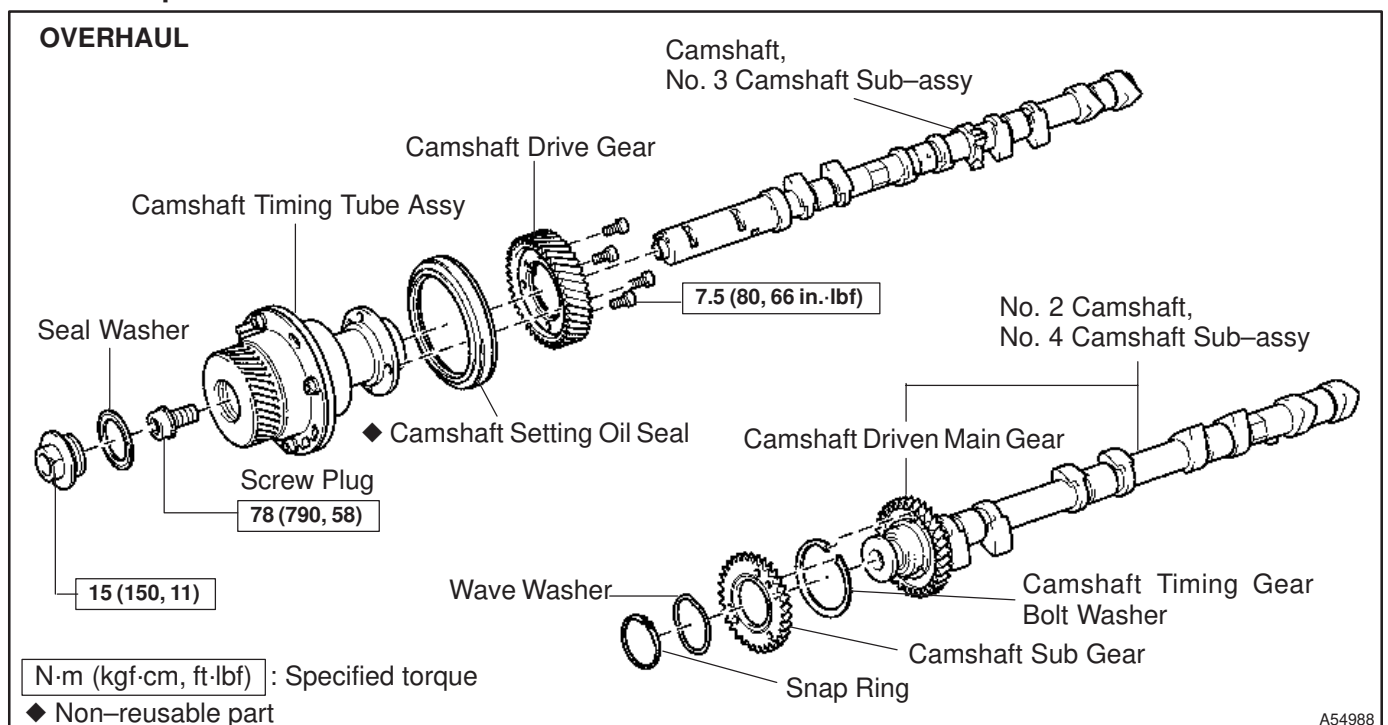

(d) Tightening torque, oil applying position, and non-reusable parts are described as important points in the procedure.

NOTICE:

There are cases where such information can only be indicated by an illustration. In that case, all the information such as torque, oil, etc. are described in the illustration.

- (e) Installing procedure of operation items is performed in the reverse order of the removing, and only the important points are described.
- (f) Only items with points are described in the procedure, and the operational portion and content are placed using an illustration. In the explanations, details of the operational method, standard value and notice are placed.
- (g) There may be a case where the illustrations of similar models are used. In that case the details may be different from the actual vehicle.
- (h) The procedures are presented in a step-by-step format:
 - (1) The illustration shows what to do and where to do it.
 - (2) The task heading tells what to do.
 - (3) The detailed text tells how to perform the task and gives other information such as specifications and warnings.

Example:

*Illustration:
what to do and where*

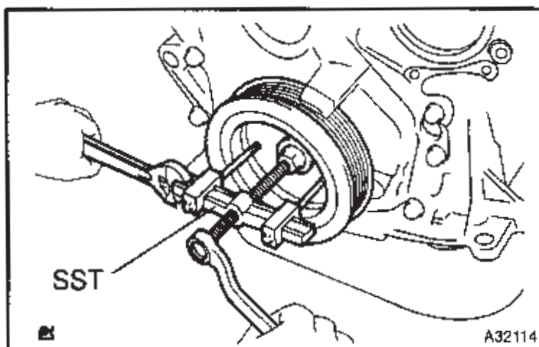

Task heading: what to do

5. REMOVE CRANKSHAFT PULLEY

- (a) Using SST, remove the crankshaft pulley.
SST 09950-50012 (09951-05010, 09952-05010, 09953-05020, 09954-05020, 09957-04010)
 - Set part No.* (points to 09950-50012)
 - Component part No.* (points to 09951-05010, 09952-05010, 09953-05020, 09954-05020, 09957-04010)
 - Detailed text: how to do task* (points to the entire instruction)

A59974

HINT:

This format provides an experienced technician with a FAST TRACK to the necessary information. The task heading can be read at a glance when necessary, and the text below provides detailed information. Important specifications and warnings always stand out in bold type.

5. SERVICE SPECIFICATIONS

- (a) Specifications are presented in bold type throughout the manual. You never have to leave the procedure to look up your specifications. The specifications are also found in the Service Specifications section for a quick reference.

6. TERMS DEFINITION

CAUTION	Indicate the possibility of injury to you or other people.
NOTICE	Indicate the possibility of damage to the components being repaired.
HINT	Provide additional information to help you perform the repair efficiently.

7. SI UNIT

- (a) The UNITS given in this manual are primarily expressed according to the SI UNIT (International System of Unit), and alternately expressed in the metric system and in the English System.

Example:

Torque: 30 N·m (310 kgf·cm, 22 ft·lbf)