

ENGINE MECHANICAL SYSTEM

GENERAL	EM - 2
ENGINE BLOCK	EM -21
MAIN MOVING SYSTEM	EM -35
COOLING SYSTEM	EM -46
LUBRICATION SYSTEM	EM -58
INTAKE AND EXHAUST SYSTEM	EM -63
CYLINDER HEAD ASSEMBLY	EM -78
TIMING SYSTEM	EM -86

GENERAL

WARNING ECHB0100

REMOVAL AND INSTALLATION OF INJECTOR AND HIGH PRESSURE PUMP.

1. Fuel system is subject to extremely high pressure (1350 bar).
2. Never perform any work on injection system with engine running or within 30 seconds after stopping the engine.
3. Always pay attention to safety precautions.
4. Ensure the absolute cleanliness.
5. Never remove the injectors.

2.0TCI ENGINE

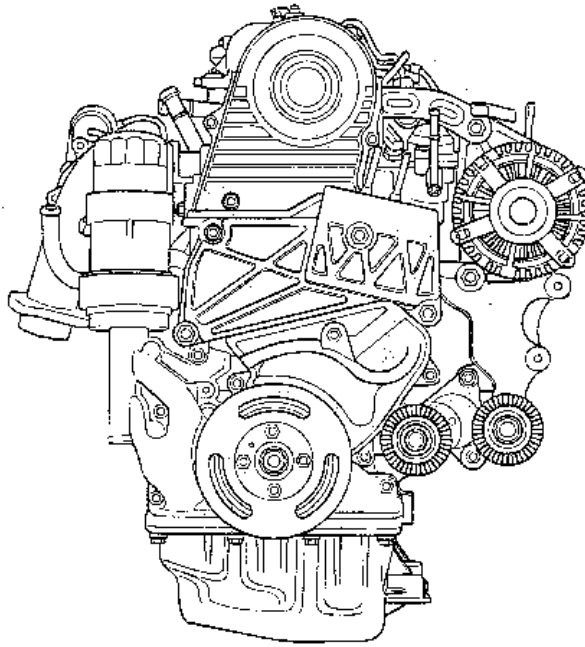

TORQUE : Nm (kg·cm, lb· ft)

KCHB001A

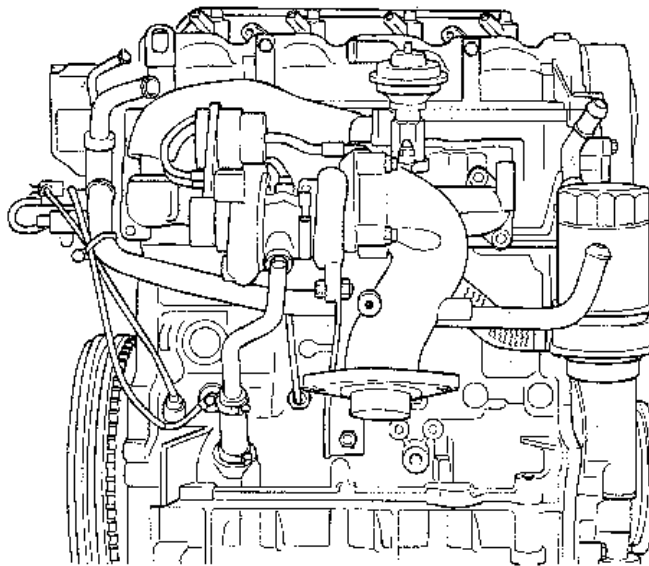

TORQUE : Nm (kg·cm, lb· ft)

KCHB001B

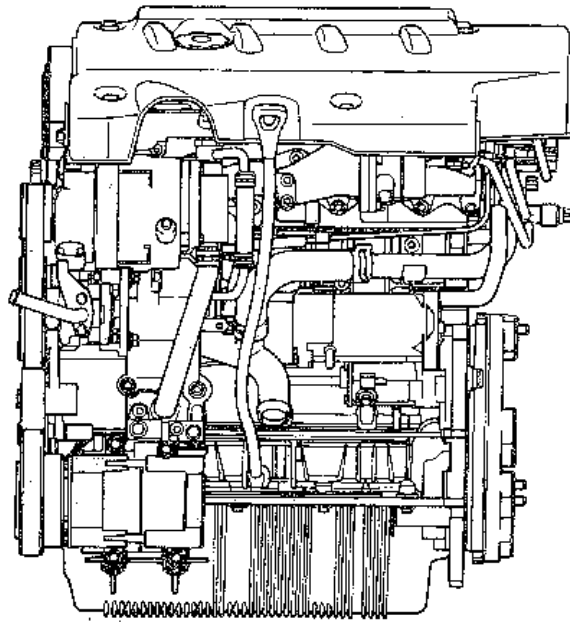

TORQUE : Nm (kg·cm, lb·ft)

KCHB001C

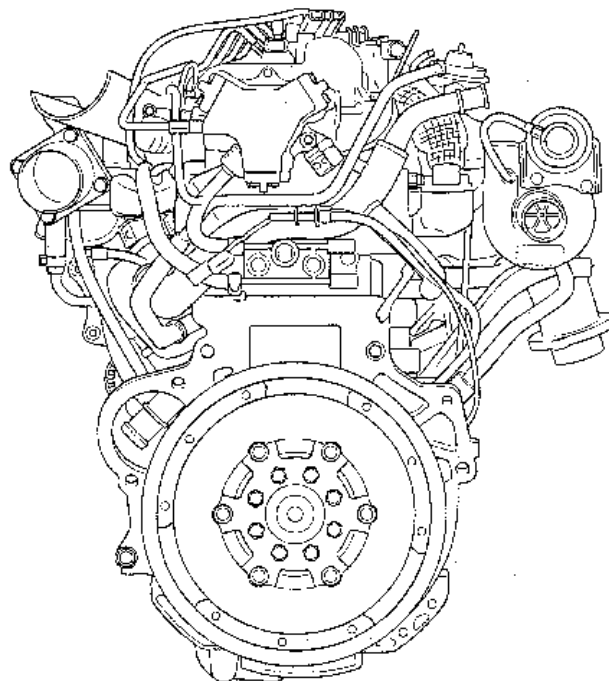

TORQUE : Nm (kg·cm, lb·ft)

KCHB001D

SPECIFICATIONS(D4EA) ECHB0200

Description	Specification 2.0(D4EA)	Limit
General Type Number of cylinders Bore Stroke Total displacement Compression ratio Firing order	In-line, Single Overhead Camshaft 4 83 mm (3.27 in.) 92 mm (3.62 in.) 1991 cc (121.5 cu.in.) 17.7:1 1-3-4-2	
Valve timing Intake valve Opens (BTDC) Closes (ABDC) Exhaust valve Opens (BBDC) Closes (ATDC)	7° 43° 52° 6°	
Cylinder head Flatness of gasket surface Dimensions for reworking oversize valve seat hole Intake 0.3 mm (0.012 in.) O.S. 0.6 mm (0.024 in.) O.S. Exhaust 0.3mm (0.012 in.) O.S. 0.6mm (0.024 in.) O.S.	Max. 0.03 mm (0.0012 in.) 29.993-30.006 mm (1.18-1.1813 in.) 30.023-30.036 mm (1.182-1.1825 in.) 25.393-25.406 mm (0.9997-1.0002 in.) 25.423-25.436 mm (1.0009-1.0014 in.)	0.2 mm (0.008 in.)
Dimensions for reworking oversize valve guide hole (both intake and exhaust) 0.05mm (0.002in.) O.S. 0.25mm (0.010in.) O.S. 0.50mm (0.020in.) O.S.	12.805-13.205 mm (0.504-0.519 in.) 12.825-13.225 mm (0.5049-0.5206 in.) 12.85-13.25 mm (0.5059-0.5216 in.)	
Camshaft Cam height Intake Exhaust Journal O.D. Bearing oil clearance End play	34.697 mm (1.366 in.) 34.570 mm (1.361 in.) 28 mm (1.10 in.) 0.040-0.074 mm (0.0020-0.0029 in.) 0.05-0.15 mm (0.002-0.006 in.)	34.197 mm (1.346 in.) 34.070 mm (1.341 in.)

Description	Specification 2.0(D4EA)	Limit
Valve Valve length Intake Exhaust Stem O.D. Intake Exhaust Face angle Thickness of valve head (margin) Intake Exhaust Valve stem to valve guide clearance Intake Exhaust	95.7 mm (3.77 in.) 95.4 mm (3.76 in.) 5.953 mm (0.234 in.) 5.925 mm (0.233 in.) 44.5° 1.6 mm (0.063 in.) 1.3 mm(0.0512 in.) 0.022-0.049 mm (0.00086-0.00193 in.) 0.050-0.077 mm (0.0020-0.0030 in.)	0.1 mm (0.0039 in.) 0.15 mm (0.0059 in.)
Valve guide Length Intake Exhaust Service over size	36.5 mm (1.437 in.) 36.5 mm (1.437 in.) 0.05, 0.25, 0.50 mm (0.002, 0.010, 0.020 in.)	
Valve seat Width of seat contact Seat angle Service size	1.21mm (0.0477 in.)/ 1.61mm(0.0634 in.) (IN/EX) 44°~44°. 5' 0.3 mm (0.012 in.), 0.6 mm (0.024 in.) oversize	
Valve spring Free length Load	39.14 mm (1.541 in.) 21.4 kg/32 mm (47.2 lb/1.26 in.) at installed height	38.14 mm (1.502 in.)
Cylinder block Cylinder bore Out-of-round and taper of cylinder bore Flatness of gasket surface	83 + 0.03 mm (3.27 + 0.0012 in.) Less than 0.01 mm (0.0004 in.) Less than 0.05 mm (0.0020 in.)	0.1 mm (0.0039 in.)

Description	Specification 2.0(D4EA)	Limit
Piston O.D. Piston - to - cylinder clearance Ring groove width No. 1 No. 2 Oil Service size	82.919 - 82.951 mm (3.26 - 3.27 in.) 0.069 - 0.091 mm (0.0027 - 0.0036 in.) 1.915 - 1.945 mm (0.075 - 0.076 in.) 2.06 - 2.08 mm (0.08 - 0.082 in.) 3.02 - 3.04 mm (0.119 - 0.1196 in.) 0.25 mm (0.010 in), 0.5 mm (0.020 in.) 0.75 mm (0.030 in.), 1.00 mm (0.039 in.) oversize	
Piston ring Side clearance No. 2 Oil ring End gap No. 1 No. 2 Oil ring side rail	0.065 - 0.11 mm (0.00256 - 0.00433 in.) 0.03 - 0.07 mm (0.00118 - 0.00275 in.) 0.2 - 0.3 mm (0.0079 - 0.0118 in.) 0.3 - 0.45 mm (0.0118 - 0.0177 in.) 0.2 - 0.45 mm (0.0079-0.0177 in.)	
Connecting rod Connecting rod pin O.D. Connecting rod bearing oil clearance Crankshaft main bearing oil clearance	28.022 - 28.034 mm (1.103 - 1.104 in.) 0.024 - 0.042 mm (0.0009 - 0.0016 in.) 0.024-0.042 mm (0.0009-0.0016 in.)	0.1 mm (0.0039 in.) 0.1 mm (0.0039 in.)
Crankshaft Journal O.D. Out-of-round of journal and pin Taper of journal and pin End play	60.002 - 60.020 mm (2.362 - 2.363 in.) Less than 0.015 mm (0.0006 in.) Less than 0.005 (0.0002 in.) 0.09 - 0.32 mm (0.0035 - 0.0126 in.)	
Flywheel Runout		0.13 mm (0.0051 in.)
Oil pressure (1500 rpm) [Oil temperature is 95-105°C (203-221°F)]	More than 392.3 kPa (56.88 psi)	

Description	Specification 2.0(D4EA)	Limit
Oil pump Tip clearance Drive gear Driven gear Side clearance	0.12 - 0.2 mm (0.00472-0.0078 in.) 0.13 -0.23 mm (0.0051-0.009 in.) 0.02 - 0.07 mm (0.00078 - 0.0027 in.)	
Relief spring Free length Opening pressure	47.5 mm (1.835 in.) 686.5±49 kPa (99.54 ± 7.1 psi)	
Silent shaft Front journal diameter Rear journal diameter Oil clearance Front Rear	27.99 - 28.01 mm (1.102 - 1.1027 in.) 41.99 - 42.01 mm (1.6531 - 1.6539 in.) 0.050 - 0.09 mm (0.0020 - 0.0036 in.) 0.050-0.091 mm (0.0020-0.0036 in.)	
Cooling method Cooling system quantity (Radiator) Thermostat Type Normal opening temperature Opening temperature range Wide open temperature Radiator cap Main valve opening pressure Main valve closing pressure Vacuum valve opening pressure	Forced circulation with electric fan 5 lit (5.3 U.S.qts., 4.4 Imp.qts.) Wax pellet type with jiggle valve 82°C(180°F) 80°C-84°C (176°F-183°F) 95°C (203°F) 107.9±14.7 kPa (1.1±0.15 kg/cm ² , 15.64±2.13 psi) 83.4 kPa (0.85 kg/ cm ² , 12.1 psi) -6.86 kPa (-0.07 kg/ cm ² , -1.00 psi)	
Air cleaner Type Element Exhaust pipe Muffler Suspension system	Dry type Unwoven cloth type Expansion resonance type Rubber hangers	
Coolant temperature sensor Type Resistance 20°C (68°F) 80°C (176°F)	Thermister type 2.45±0.14 kΩ 0.3222 kΩ	

SERVICE STANDARDS

Standard value

Coolant concentration

Tropical area

40%

Other area

50%

LUBRICANT

Engine coolant

Ethylene glycol base for aluminum radiator

SEALANT

Engine coolant temperature sensor

LOCTITE 262, three bond No. 1324 or equivalent

Oil pressure switch

3M ATD No. 8660 or Three bond No. 1141E



 **NOTE***O.D.= Outer Diameter**I.D.= Inner Diameter**O.S.= Oversize Diameter**U.S. = Undersize Diameter*



TIGHTENING TORQUE SC-60900

Item	Nm	kg-cm	Lb-ft
Engine mount insulator bolt	90-110	900-1100	65-80
Engine mounting bracket nuts	60-80	600-800	43-58
Engine mounting bracket bolts	60-80	600-800	43-58
Engine Support bracket bolt and nut	43-55	430-550	32-40
Front roll stopper bracket to cross member bolts	40-55	400-550	29-40
Front roll stopper insulator bolt and nut	50-65	500-650	36-47
Rear roll stopper bracket to cross member bolts	50-65	500-650	36-47
Rear roll stopper insulator bolt and nut	50-65	500-650	36-47
Transaxle mounting bracket bolts	60-80	600-800	43-58
Transaxle mounting insulator bolt	90-110	900-1100	65-80
Front exhaust pipe to exhaust manifold	30-40	300-400	22-29
Rocker cover bolt	10-14	100-140	7-10
Camshaft sprocket bolt	120-150	1200-1500	88-110
Camshaft bearing cap bolt	27-30	270-300	20-22
Crankshaft position sensor	7-11	70-110	5-8
Air cleaner body installation bolt	8-10	80-100	6-7
Crankshaft sprocket bolt	185-195	1850-1950	136-144
Damper pulley to crankshaft sprocket	30-34	300-340	22-25
Cylinder head bolt (cold engine)	50+120°+90°	500+120°+90°	36+120°+90°
Timing belt auto tensioner bolt	50-55	500-550	36-40
Drive belt Auto tensioner bolt	26-31	260-310	19-23
Timing belt auto tensioner adjustable bolt	10-12	100-120	7-9
Drive belt idler bolt	46-51	460-510	34-38
Front exhaust pipe clamp bolt	20-30	200-300	14-22
Oil pan	10-12	100-120	7-9
Oil pan drain plug	35-45	350-450	25-33
Oil screen	10-12	100-120	7-9
Oil pressure switch	15-22	150-220	11-16
Oil screen bracket bolt	34-38	340-380	25-28
Oil pump cover bolt	20-27	200-270	15-20
Oil seal case bolt	10-12	100-120	7-9
Plug cap	20-27	200-270	14-20
Oil jet bolt	9-13	90-130	7-10
Oil pump rotor bolt	8-10	80-100	6-9
Timing belt upper cover	8-12	80-120	6-9
Timing belt lower cover	8-12	80-120	6-9
Relief plug	42-52	420-520	31-38

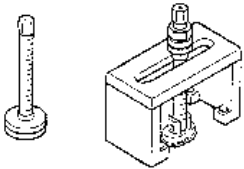
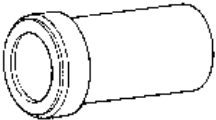
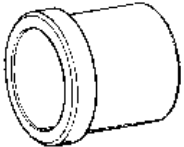
Item	Nm	kg-cm	Lb-ft
Flywheel	70-80	700-800	52-59
Drive plate	70-80	700-800	52-59
Connecting rod cap bolt	25+90°	250+90°	18+90°
Engine coolant pump to cylinder block bolt			
14 mm	48-52	480-520	35-38
10 mm	10-12	100-120	7-9
Engine coolant temperature sensor	40-55	400-550	30-41
Engine coolant inlet fitting attaching bolt	20-25	200-250	15-18
Air cleaner mounting bolts	8-10	80-100	6-7
Resonator mounting bolt (Nut)	8-10	80-100	6-7
Intake manifold mounting bolt (M8)	15-20	150-200	11-14
Front exhaust manifold bolt to cylinder block	25-38	250-380	18-28
Center exhaust pipe nuts to catalytic converter	30-40	300-400	22-29
Center exhaust pipe bolts to main muffler	30-40	300-400	22-29
Center exhaust pipe bolt to bracket	10-15	100-150	7-11
Hanger bolt to body	10-15	100-150	7-11
Hanger bolt to main muffler	10-15	100-150	7-11
Exhaust manifold nuts	25-38	250-380	18-28
Oxygen sensor	40-50	400-500	29-36
Heat protector bolt to exhaust manifold	12-15	120-150	9-11
Air cleaner bracket bolt	10-13	100-130	7-9
Exhaust manifold cover to exhaust manifold bolt	12-15	120-150	9-11
Oxygen sensor to exhaust manifold	40-50	400-500	29-36
Front exhaust pipe bracket bolt	20-30	200-300	14-22
Main muffler hanger support bracket bolt	10-20	100-200	7-14
Oil level gauge	10-12	100-120	7-9
Balance shaft bolt	53-57	530-570	39-42
Starter bolt to cylinder block	48-52	480-520	35-38
Turbocharger support bolt	35-45	350-450	26-33
Crankshaft bedplate bolt			
15 mm	25+45°+90°	250+45°+90°	18+45°+90°
12 mm	33-37	330-370	24-27

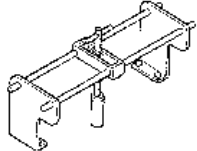
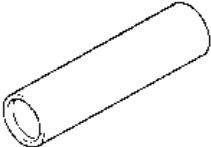
SPECIAL TOOLS ECHB0400

Tool (Number and name)	Illustration	Use
Balance shaft bearing remover&installer (09212-27000)	 <p style="text-align: right; font-size: small;">KCHB6003</p>	Removal and installation of balance shaft rear bearing (use with 09212-32300)
Balance shaft drive gear and camshaft oil seal installer (09214-32000)	 <p style="text-align: right; font-size: small;">ECA9930A</p>	Installation of the balance shaft drive gear on crankshaft and camshaft oil seal
Front case oil seal installer (09231-27100)	 <p style="text-align: right; font-size: small;">ECA9930C</p>	Installation of the front case oil seal
Valve guide remover (09222-27100)	 <p style="text-align: right; font-size: small;">ECHB6001</p>	Removal of valve guides
Valve spring compressor (09222-27300)	 <p style="text-align: right; font-size: small;">KCHB600C</p>	Removal and installation of inlet and exhaust valves
Valve stem oil seal installer (09222-27200)	 <p style="text-align: right; font-size: small;">KCH-B600E</p>	Installation of valve stem oil seals

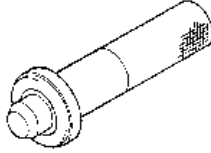
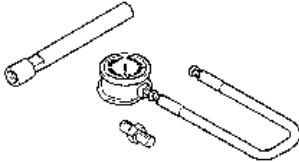
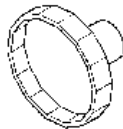
Tool (Number and name)	Illustration	Use
Valve guide installer (09222-27000)	 <p style="text-align: right; font-size: small;">KCHB500F</p>	Installation of valve guides
Crankshaft rear oil seal installer (09231-27000)	 <p style="text-align: right; font-size: small;">KCHB600G</p>	Installation of the crankshaft rear oil seal
Injector oil seal installer (09351-27400)	 <p style="text-align: right; font-size: small;">KCHB600A</p>	Installation of the injector oil seal
Compression gauge&adapter (09351-27000) (09351-27100)	 <p style="text-align: right; font-size: small;">KC-ID600D</p>	Checking engine compression pressure
Oil filter wrench (09263-27100)	 <p style="text-align: right; font-size: small;">KCHB600H</p>	Removal and installation of oil filter

TROUBLESHOOTING

EC11A0400

Symptom	Probable cause	Remedy
Low compression	Damaged cylinder head gasket Worn or damaged piston rings Worn piston or cylinder Worn or damaged valve seat	Replace gasket Replace rings Repair or replace piston and/or cylinder block Repair or replace valve and/or seat ring
Oil pressure drop	Low engine oil level Faulty oil pressure switch Clogged oil filter Worn oil pump gears or cover Thin or diluted engine oil Oil relief valve stuck (open) Excessive bearing clearance	Check engine oil level Replace Replace Replace Change and find out cause Repair Replace
High oil pressure	Oil relief valve stuck (closed)	Repair
Excessive engine vibration	Loose engine roll stopper (front, rear) Loose transaxle mount bracket Loose engine mount bracket Loose center member Broken transaxle mount insulator Broken engine mount insulator Broken engine roll stopper insulator	Re-tighten Re-tighten Re-tighten Re-tighten Replace Replace Replace
Noisy valves	Thin or diluted engine oil (low oil pressure) Worn or damaged valve stem or valve guide	Change Replace
Connecting rod and/main bearing noise	Insufficient oil supply Thin or diluted engine oil Excessive bearing clearance	Check engine oil level Change and find out cause Replace
Timing belt noise	Incorrect belt tension (alternator tensioner, timing belt)	Adjust belt tension
Low coolant level	Leakage of coolant Damaged radiator core joint Corroded or cracked hoses (radiator hose, heater hose, etc) Faulty radiator cap valve or setting of spring Faulty thermostat Faulty engine coolant pump	Replace Replace Replace Replace Replace
Clogged radiator	Foreign material in coolant	Replace
Abnormally high coolant temperature	Faulty thermostat Faulty radiator cap Restricted of flow in cooling system Loose or missing drive belt Faulty engine coolant pump Faulty temperature sensor wiring Faulty electric fan Faulty thermo-sensor on radiator Insufficient coolant	Replace Replace Replace Adjust or replace Replace Repair or replace Repair or replace Replace Refill coolant
Abnormally low coolant temperature	Faulty thermostat Faulty temperature sensor wiring	Replace Repair or replace

Symptom	Probable cause	Remedy
Leakage from oil cooling system	Loose hose and pipe connection Blocked or collapsed hose and pipe	Retighten Replace
Inoperative electrical cooling fan	Damaged, fuse	Replace or repair
Exhaust gas leakage	Loose connections Broken pipe or muffler	Retighten Repair or replace
Abnormal noise	Detached baffle plate in muffler Broken rubber hanger Pipe or muffler contacting vehicle body Broken pipe or muffler	Replace Replace Correct Repair or replace

CHECKING ENGINE OIL ECJA0500

1. Position a vehicle on a level surface.
2. Turn off the engine.

NOTE

If a vehicle that has not been used for a prolonged period, run the engine for several minutes. Turn off the engine and wait for 5 minutes at least, and then check the oil level.

3. Check that the engine oil level is within the level range indicated on the oil dipstick. If the oil level is found to have fallen to the lower limit (the "L" mark), refill to the "F" mark.

NOTE

When refilling, use the proper grade of engine oil.

4. Check that the oil is not dirty or mixed with coolant or gasoline and it has the proper viscosity.

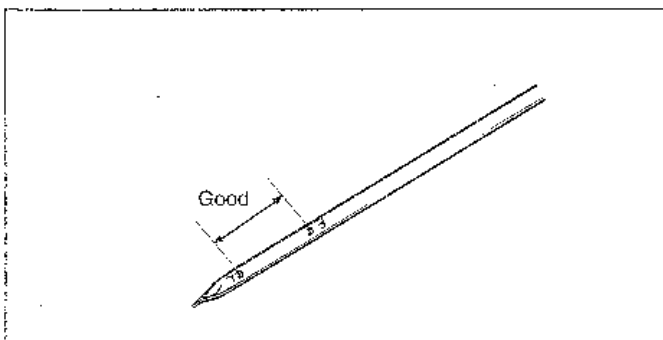

EDAR000A

SELECTION OF ENGINE OIL ECH80700

Recommended API classification: CE OR ABOVE SE OR ABOVE [For EC.]

Recommended SAE viscosity grades:

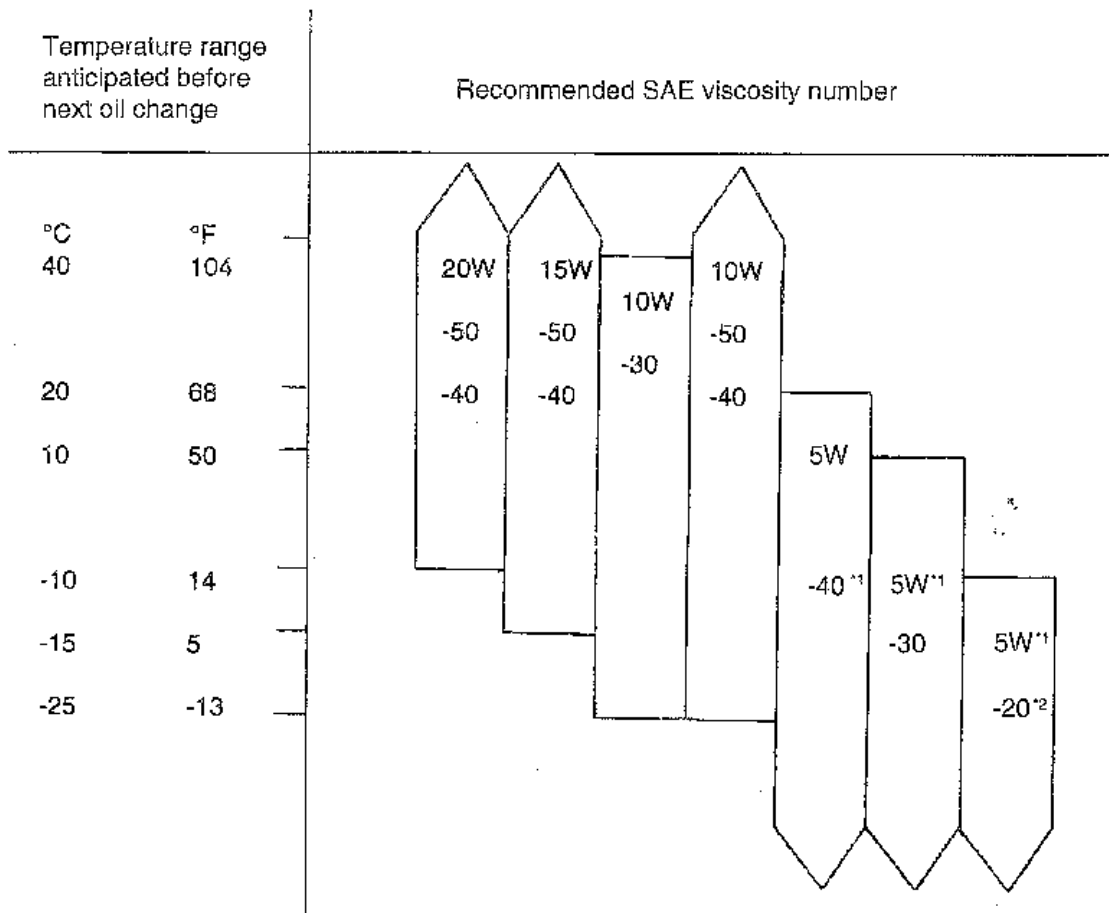

*1 Restricted by driving condition and environment.

*2 Not recommended for sustained high speed vehicle operation

ECA8990B

NOTE

For best performance and maximum protection of all types of operation, select only those lubricants which:

1. Satisfy the requirements of the API classification.
2. Have the proper SAE grade number for expected ambient temperature range.

Lubricants which do not have both SAE grade number and an API service classification on the container should not be used.

CHANGING ENGINE OIL ECHB0800

1. Run the engine until it reaches normal operating temperature.
2. Turn off the engine.
3. Remove the oil filler cap and the drain plug. Drain the engine oil.

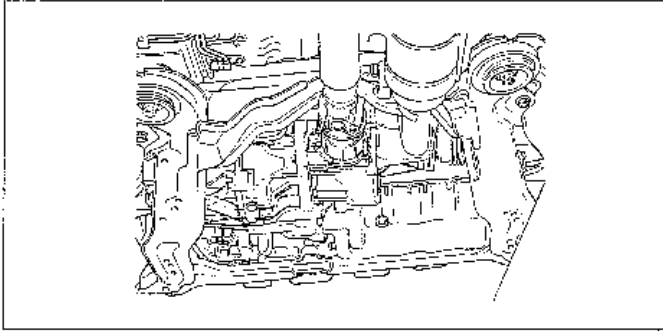

KCHB002D

4. Tighten the drain plug to the specified torque.

Tightening torque

Oil pan drain plug :

35-45 Nm (350-450 kg.cm, 25-33 lb.ft)

NOTE

Whenever tightening the oil drain plug, use a new drain plug gasket.

5. Fill new engine oil through the oil filler cap opening.

Capacity :

Drain and refill : 5.4 lit (5.7 U.S.qts., 4.75 Imp.qts.)

Oil filter : 0.5 lit (0.53 U.S.qts., 0.44 Imp.qts.)

Total : 5.9 lit (6.23 U.S.qts., 5.19 Imp.qts)

NOTE

Do not overfill. This will cause oil aeration and loss of oil pressure.

6. Install the oil filler cap.
7. Start and run the engine.
8. Turn off the engine and then check the oil level. Add oil if necessary.

REPLACING THE OIL FILTER ECHB0900

All Hyundai Motor Company engines are equipped with a high quality, disposable oil filter. The quality of aftermarket replacement filters is considerably diverse.

High quality replacement filters should be used to assure the most efficient service.

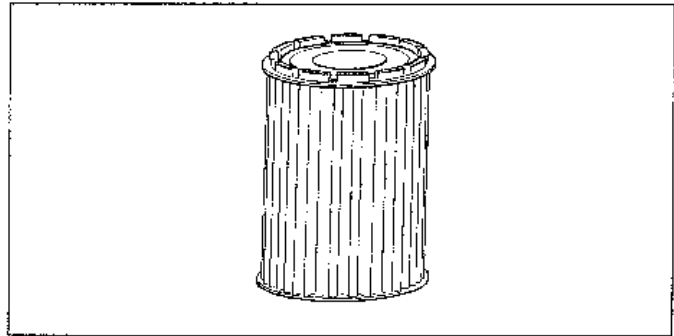

ECHB001A

PROCEDURE FOR REPLACING THE OIL FILTER

1. Use a filter wrench (09263 - 27100) to remove the oil filter upper cap.
2. Installing a new oil filter on the lower case.
3. Tighten the oil filter upper cap to the specified torque.

Oil filter : 22-25 Nm (220-250 kg.cm, 16-18 lb.ft)

4. Start and run the engine and check for engine oil leak.
5. After turning off the engine, check the oil level and add oil as necessary.

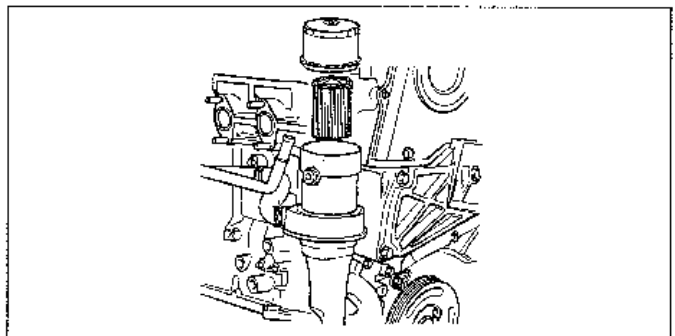

ECH-B001B

CHECKING COOLANT LEAK ECHR1000

1. Loosen the radiator cap.
2. Confirm that the coolant level is up to the filler neck.
3. Install a radiator cap tester to the radiator filler neck and apply 150 KPa (21psi, 1.53 kg/cm²) pressure. Hold it for two minutes in that condition while checking for leakage from the radiator, hoses or connections.

NOTE

1. Radiator coolant may be extremely hot. Do not open the system because hot, or scalding water could gush out causing personal injury. Allow the vehicle to cool before servicing this system.
 2. When the tester is removed, be careful not to spill any coolant from it.
 3. Be sure to clean away completely any from the area.
 4. Be careful when installing and removing the tester and when testing, not to deform the filler neck of the radiator.
4. If there is leakage, repair or replace with the appropriate part.

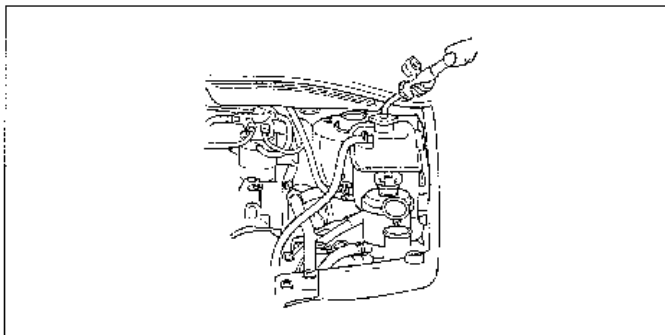

KCH-B002A

NOTE

Be sure that the cap is clean before testing, since rust or other foreign material on the cap seal will cause an incorrect reading.

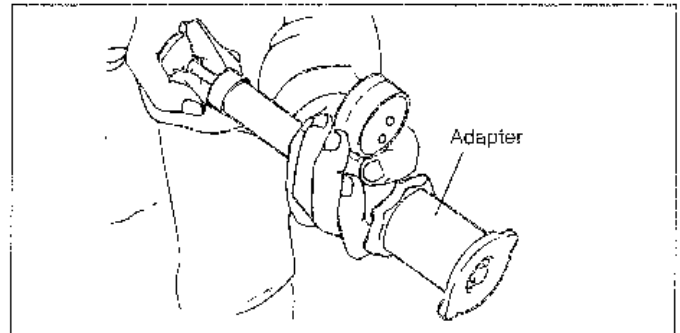

ECA9090A

SPECIFIC GRAVITY TEST ECHR100

1. Measure the specific gravity of the coolant with a hydrometer.
2. Measure the coolant temperature and calculate the concentration from the relation between the specific gravity and temperature, using the following table for reference.

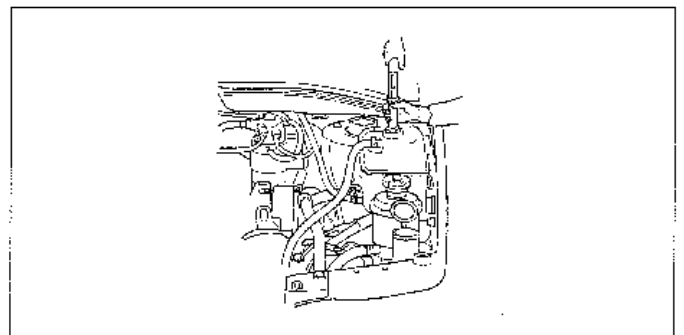

KCH-B002B

RADIATOR CAP PRESSURE TEST

1. Use an adapter to attach the cap to the tester.
2. Increase the pressure until the gauge stops moving.

Main valve opening pressure :

107.9kPa±14.7kPa (1.1±0.15 kg/cm², 15.64±2.13)

Main valve closing pressure :

83.4 kPa (0.85 kg/cm², 12.1 psi)

3. Check that the pressure level is maintained at or above the limit.
4. Replace the radiator cap if the reading does not remain at or above the limit.

RELATION BETWEEN COOLANT CONCENTRATION AND SPECIFIC GRAVITY

Coolant temperature °C (°F) and specific gravity					Freezing temperature °C (°F)	Safe operating temperature °C (°F)	Coolant concentration (Specific volume)
10 (50)	20 (68)	30 (86)	40 (104)	50 (122)			
1.054	1.050	1.046	1.042	1.036	-16 (3.2)	-11 (12.2)	30%
1.063	1.058	1.054	1.049	1.044	-20 (-4)	-15 (5)	35%
1.071	1.067	1.062	1.057	1.052	-25 (-13)	-20 (-4)	40%
1.079	1.074	1.069	1.064	1.058	-30 (-22)	-25 (-13)	45%
1.087	1.082	1.076	1.070	1.064	-36 (-32.8)	-31 (-23.8)	50%
1.095	1.090	1.084	1.077	1.070	-42 (-44)	-37 (-35)	55%
1.103	1.098	1.092	1.084	1.076	-50 (-58)	-45 (-49)	60%

Example

The safe operating temperature is -15°C (5°F) when the measured specific gravity is 1.058 at coolant temperature of 20°C (68°F)

- if the concentration is above 60%, both the anti-freeze and engine cooling property will decrease, affecting the engine adversely. For these reasons, be sure to maintain the concentration level within the specified range.
- Do not mix types of anti-freeze.

 CAUTION

- If the concentration of the coolant is below 30%, its anti-corrosion properties will be adversely affected.

RECOMMENDED COOLANT

Antifreeze	Mixture ratio of anti freeze in coolant
ETHYLENE GLYCOL BASE FOR ALUMINUM	50% [Except tropical areas] 40% [Tropical areas]

CHECKING COMPRESSION

PRESSURE ECHB1200

1. Before checking engine compression, check the engine oil level. Also check that the starter motor and battery are all in normal operating condition.
2. Start the engine and wait until the engine coolant temperature reaches 80-95°C (176-205°F).
3. Turn off the engine and remove the aircleaner element.
4. Remove the injectors.
5. Crank the engine to remove any foreign material in the cylinders.
6. Insert the compression gauge (09351 - 27000) into the injector hole.

7. Crank the engine and read the gauge.

Standard value : 2942 kpa (30 Kg/cm², 426 psi)

8. Repeat steps 6 to 7 for all cylinders, ensuring that the pressure difference for each of the cylinders is within the specified limit.

Limit : Max. 100 kpa (1.0 kg/cm², 14 psi) between cylinders

9. If a cylinder's compression or pressure differential is outside the specification, add a small amount of oil through the injector hole, and repeat steps 6 to 8.
 - 1) If the addition of oil causes the compression to rise, it is likely that there may be wear between the piston ring and cylinder wall.

- 2) If compression remains the same, valve seizure, poor valve seating or a compression leak from the cylinder head gasket are all possible causes.

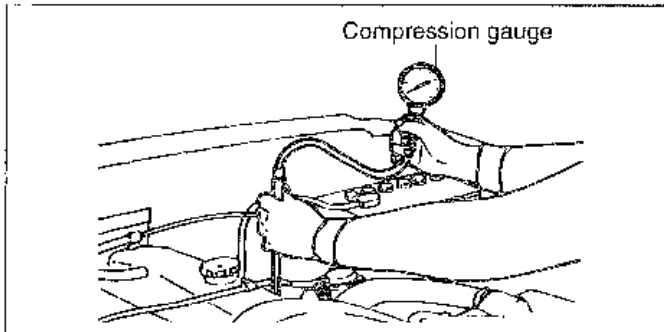

ECLA005A

ADJUSTING DRIVE BELT AND TENSIONER

ECH81300

1. Check that the belts are not damaged and are properly placed for the pulley grooves.

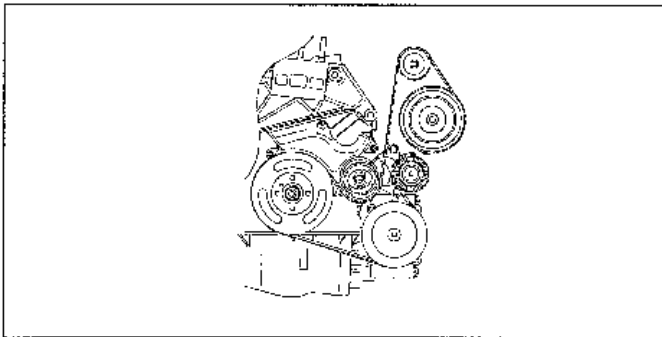

KC-HB002E

2. Install the belt in the following order.
[Alternator ⇒ Power steering ⇒ Idler ⇒ Air conditioner pulley ⇒ Crankshaft pulley]
3. When installing the belt on the pulley, make sure it is centered on the pulley

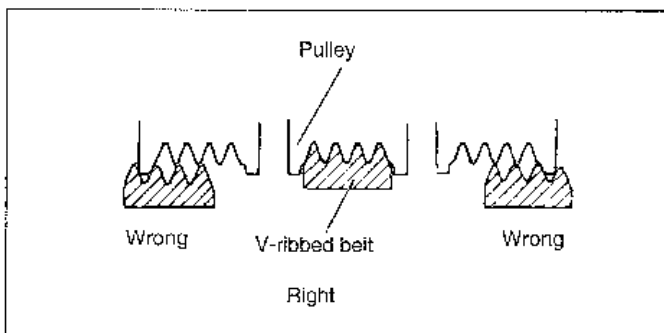

ECA9980A

⚠ CAUTION

1. When installing the V-ribbed belt, check that the V-ribs are properly aligned.
 2. If noise or slippage is detected, check the belt for wear, damage, or breakage on the pulley contact surface, and check the pulley for scoring. Also check the amount that the belt is deflected.
4. The tensioner mark should be between the “*” position.
If not, replace the belt.

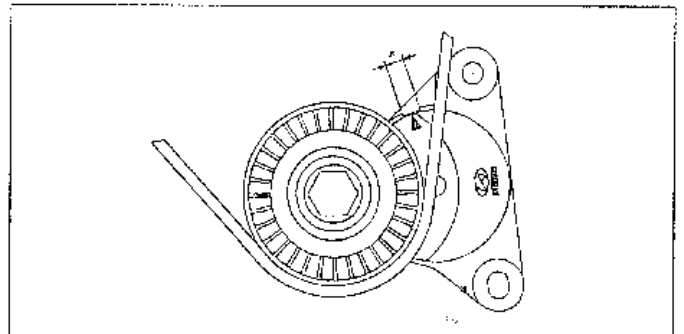

KCHB002F

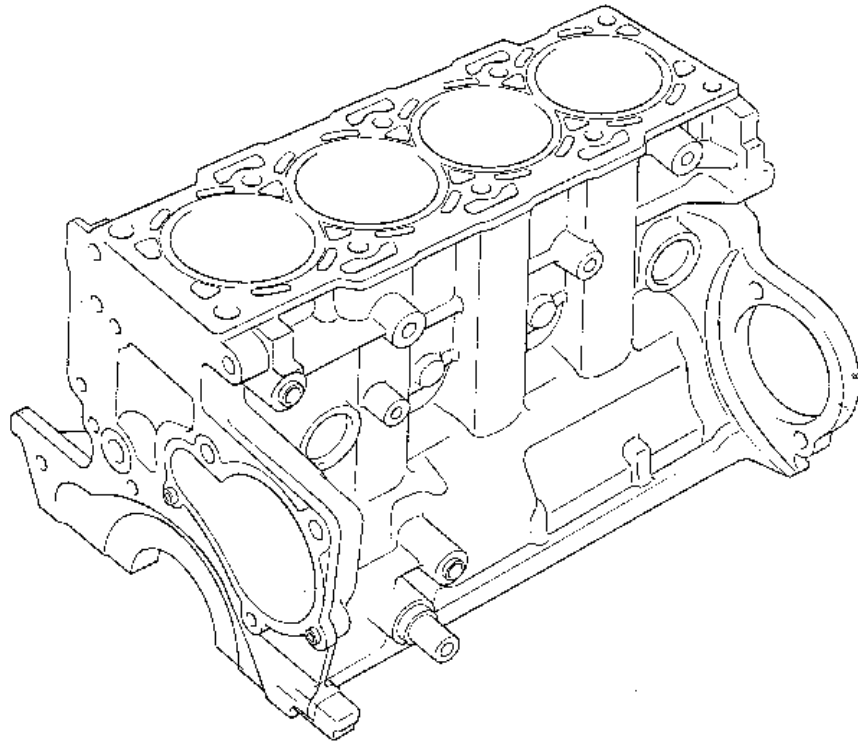
ENGINE BLOCK**ENGINE BLOCK****COMPONENTS** ECHB1500

TORQUE : Nm (kg·cm, lb·ft)

KCHB003A

DISASSEMBLY ECHA1600

Remove the cylinder head, timing belt, front case, flywheel, pistons and crankshaft.

For further details, refer to the appropriate section.

INSPECTION ECA94500

CYLINDER BLOCK

1. Check the cylinder block for scores, rust and corrosion. Also check for cracks or any other defects. Replace the block if defective.
2. Measure the cylinder bore with a cylinder gauge at the three levels indicated and in the directions of A and B.
 Level 1 : No. 1 piston ring position at TDC
 Level 2 : Center of cylinder
 Level 3 : Bottom of cylinder

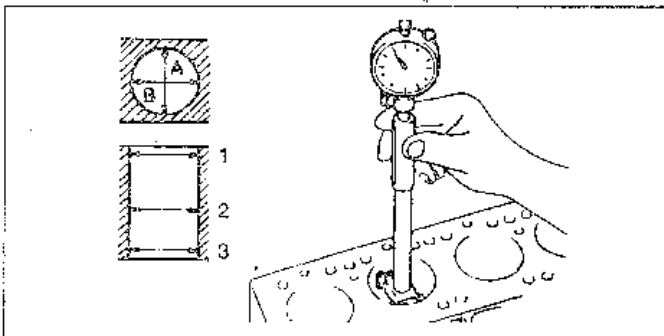

ECA9450A

3. If the cylinder bores show more than specified out-of-round or taper, or if the cylinder walls are badly scuffed or scored, the cylinder block should be rebored and honed. New oversize piston and rings should be installed.

Standard value

Cylinder bore : 83+0.03 mm (3.27+0.0012 in.)

Out-of -round and taper of cylinder bore :
 Max. 0.01mm(0.0004 in.)

4. If a ridge exists at the top of the cylinder, cut it away with a ridge reamer.

PISTON SERVICE SIZE AND MARK MM (IN.)

Identification Mark	Size
0.25	0.25 (0.010) O.S.
0.50	0.50 (0.020) O.S.
0.75	0.75 (0.030) O.S.
1.00	1.00 (0.039) O.S.

5. To rebore the cylinder bore to oversize, maintain the specified clearance between the oversize piston and the bore, and make sure that all pistons used are of the same oversize. The standard measurement of the piston outside diameter is taken at a level 2 mm (0.08 in.) above the bottom of the piston skirt and across the thrust faces.

Piston-to-cylinder clearance :

0.069 - 0.091 mm

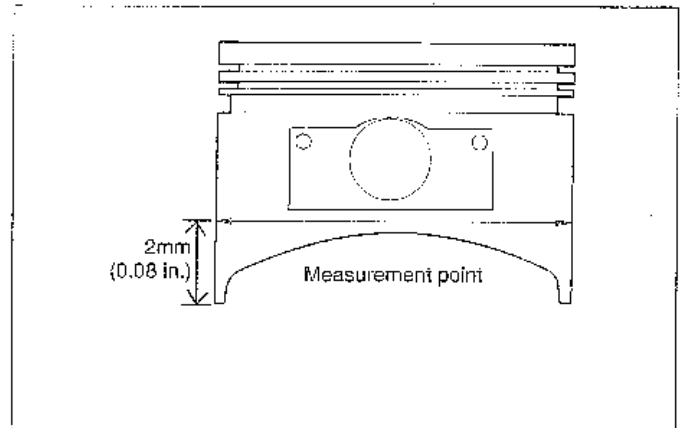

ECA9451A

6. Check for damage and cracks.
7. Check the top surface of the cylinder block for flatness. If the top surface exceeds limits, surface to minimum limit or replace.

Standard value

Flatness of cylinder block : Max. 0.05mm(0.0020 in.)

Service limit

Flatness of cylinder block : 0.1mm(0.0039 in.)

NOTE

When the cylinder head is assembled, grinding less than 0.2 mm (0.008 in.) is permissible.

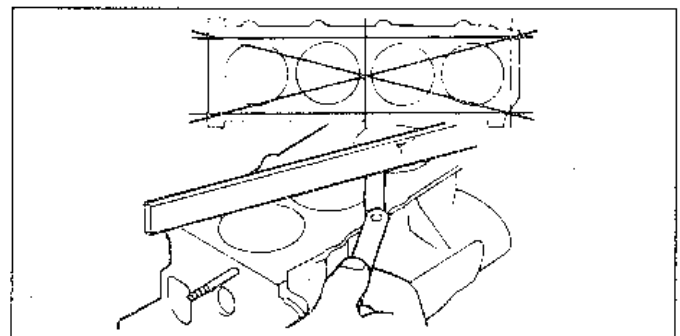

ECA9450B

BORING CYLINDER

1. Oversize pistons should be selected on the basis of the largest cylinder bore.

Identification Mark	Size
0.25	0.25 mm (0.010 in.) O.S.
0.50	0.50 mm (0.020 in.) O.S.
0.75	0.75 mm (0.030 in.) O.S.
1.00	1.00 mm (0.039 in.) O.S.

 **NOTE**

The size of a piston is stamped on top of the piston.

2. Measure the outside diameter of the piston to be used.
3. On the basis of the measured O.D., calculate the new bore size.
New bore size = Piston O.D + clearance between piston and cylinder - 0.02 mm (0.0008 in.) (honing margin.)
4. Bore each of cylinders to the calculated size.

 **NOTE**

To prevent distortion that may result from temperature rise during honing, bore the cylinders, holes in the firing order sequence.

- 5.hone the cylinders, finishing them to the proper dimension (piston outside diameter + gap with cylinder).
6. Verify the clearance between the piston and cylinder.

 **NOTE**

When boring cylinders, finish all four cylinders to the same oversize. Do not bore only one cylinder to the oversize.

REASSEMBLY ECHA1800

Install the following parts by referring to their respective paragraphs.

1. Crankshaft
2. Flywheel
3. Piston
4. Cylinder head
5. Timing belt train
6. Front case

ENGINE MOUNTS

COMPONENTS FC-B2000

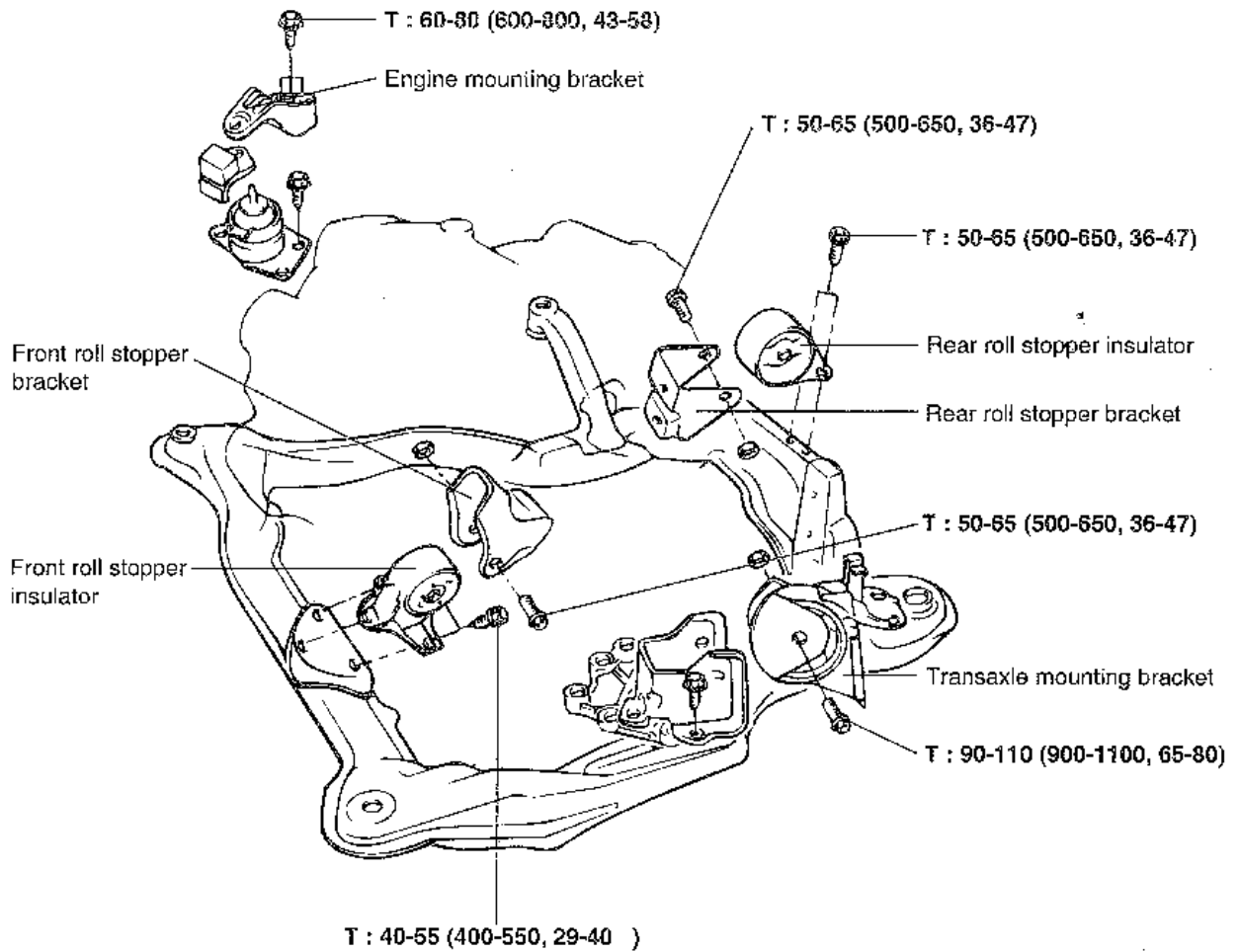

TORQUE : Nm (kg.cm, lb-ft)

REMOVAL ECA9A2150

Attach a chain or cable to the engine hooks and lift enough so that there is no pressure on the motor mounts.

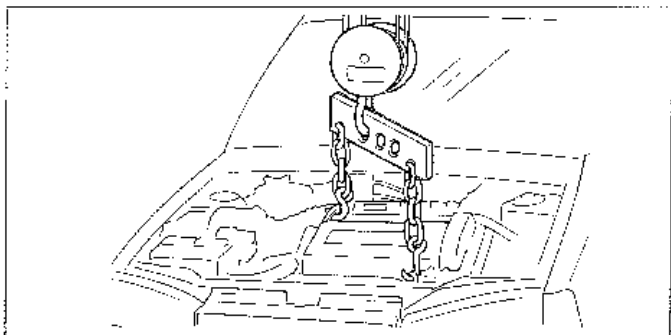

ECA9120A

ENGINE MOUNTING

1. Remove the engine mounting insulator bolts.
2. Remove the engine mounting bracket from the engine.

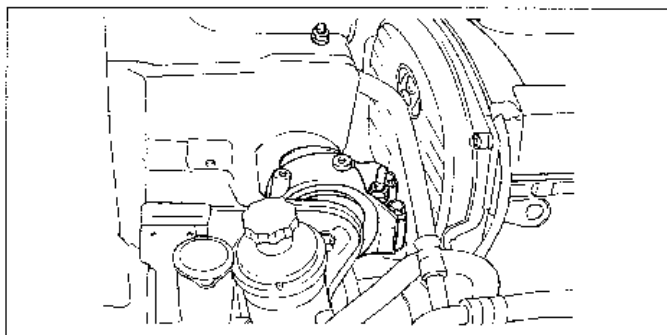

ECA9006A

TRANSAXLE MOUNTING

1. Remove the transaxle mounting insulator bolts.
2. Remove the transaxle mounting bracket from the transaxle.

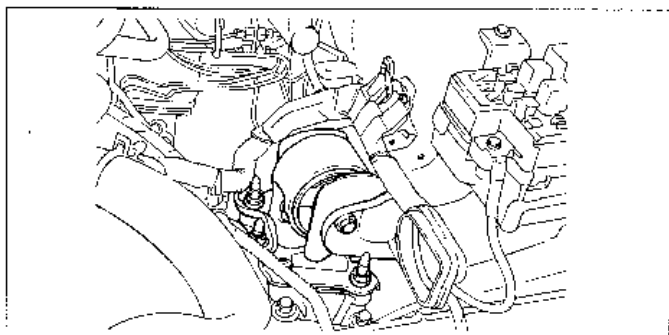

ECA9007A

FRONT ROLL STOPPER

Remove the front roll stopper bracket from the sub-frame.

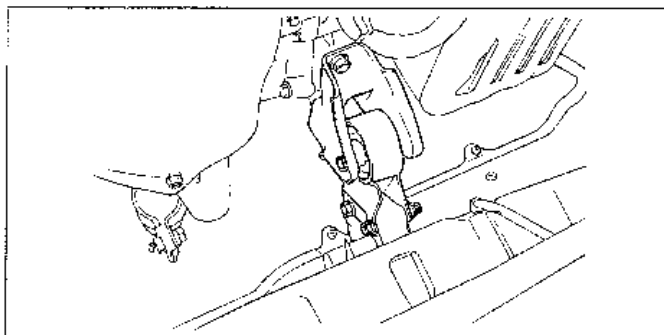

ECA9008A

REAR ROLL STOPPER

1. Remove the bolt from the rear roll stopper.
2. Remove the rear roll stopper from the subframe.

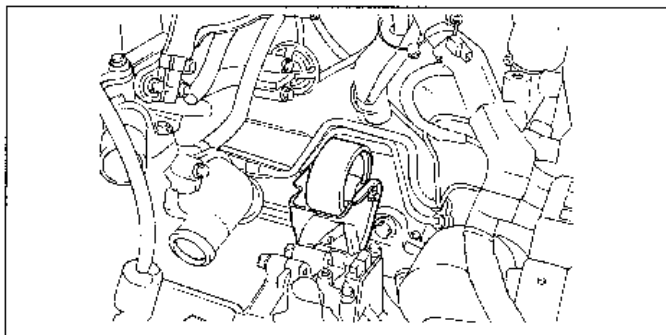

ECA9003A

INSPECTION ITEMS ECHB2200

Transaxle mounting

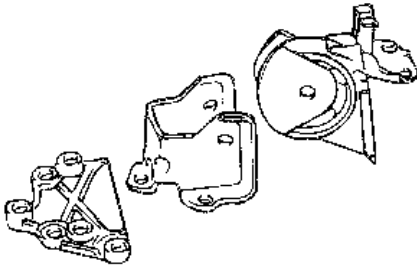

Engine mounting

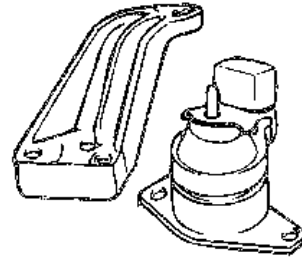

Front roll stopper assembly

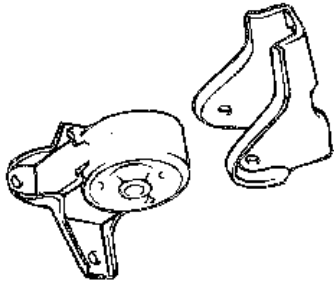

Rear roll stopper assembly

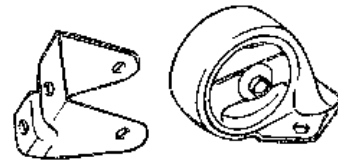

FRONT CASE

COMPONENTS ECH22500

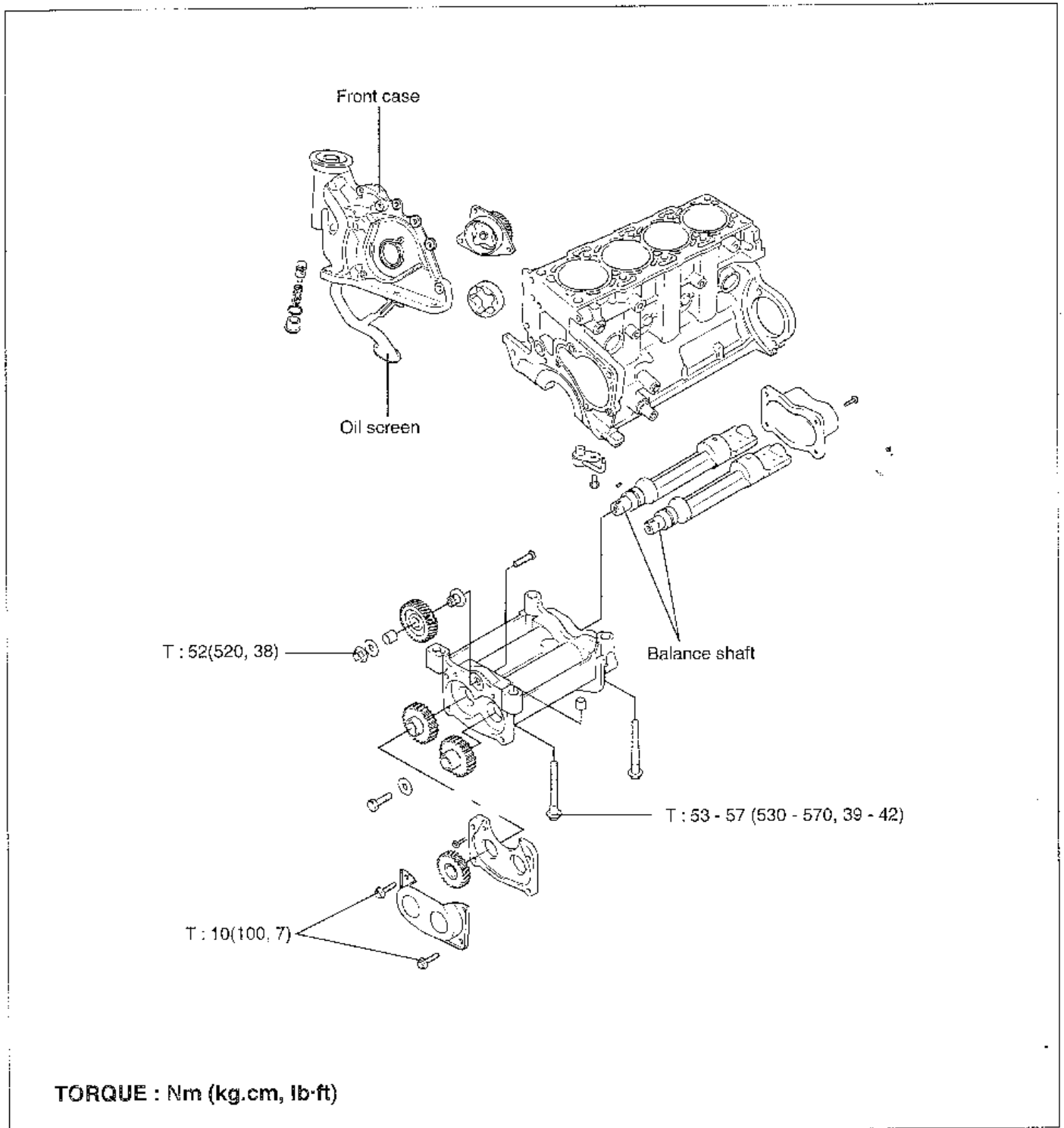

DISASSEMBLY ECHB2600

1. Remove the timing belt. Refer to "Timing Belt."
2. Remove all the oil pan bolts.
3. Tap the oil pan with a rubber hammer and remove the pan.
4. Remove the oil screen and gasket.
5. Remove the front case assembly.
6. Remove the oil pressure switch.

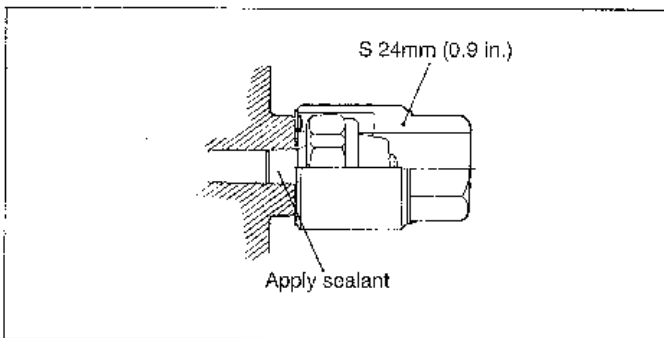

FCHA260A

7. Remove all the balance shaft bolt.

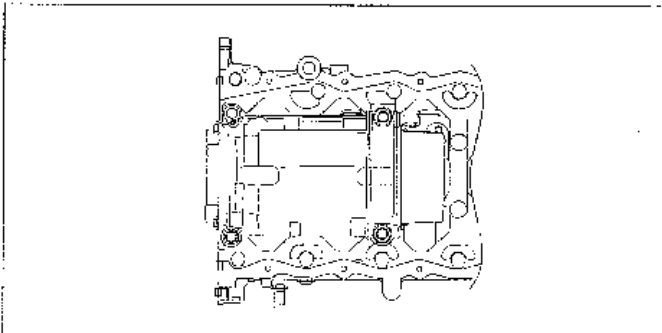

KCHB004C

8. Disassembly the balance shaft assembly.

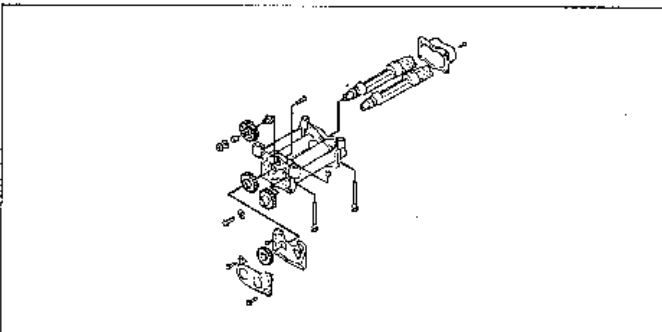

KCHB004D

9. Remove the front case mounting bolts and remove the front case assembly and gasket from the cylinder block.

10. Remove the oil pump gears from the front case.

INSPECTION ECHB2700**FRONT CASE**

1. Check all oil holes for clogging. Clean the holes if necessary.
2. Check the balance shaft bearing for wear, damage and seizure. If there is anything wrong with the bearing, replace the bearing.
3. Check the front case for cracks and other damage.
4. Replace a cracked or damaged front case.

BALANCE SHAFT

1. Check the journals for wear or seizure.
2. If excessive wear or seizure is evident, check the bearing carefully.
3. If necessary, replace the balance shaft bearing or the shaft itself.

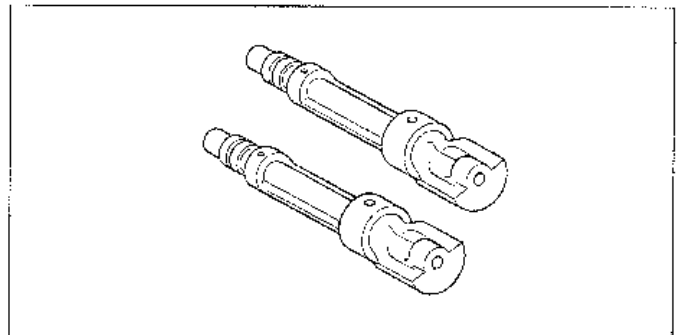

KCHB004E

OIL SEAL

1. Check the oil seal lip for wear and damage. Replace the oil seal if necessary.
2. Check the oil seal lip for deterioration. Replace the oil seal if necessary.

REASSEMBLY FCHB2302

1. Apply engine oil to the gear and align the two timing marks.

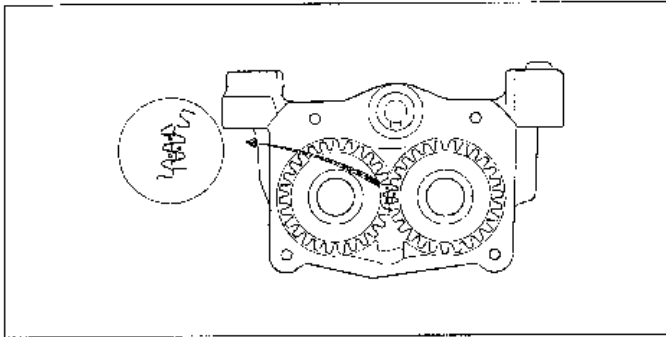

2. Apply Loctite272 to the drive gear and intermediate gear bolt.

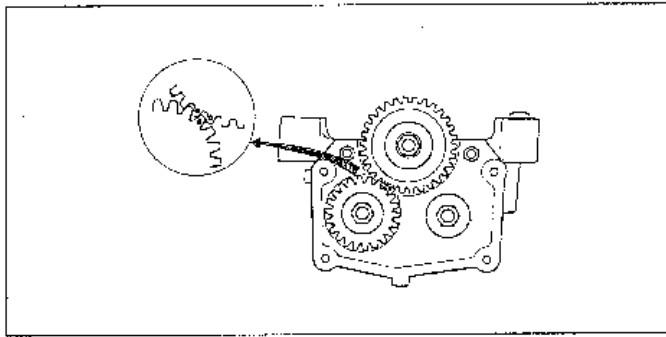

3. Using the special tool, the crankshaft front oil seal installer (09231-27100), install the crankshaft front oil seal into the front case.

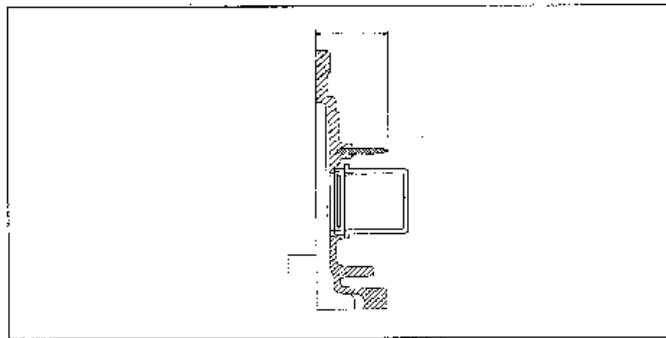

4. Install a new front case gasket to the front case assembly and tighten the flange bolts temporarily.

5. Install the front case assembly with a new gasket. Tighten bolts to the specified torque.

Tightening torque

Front case assembly :

20-27Nm(200-270kg.cm, 14-20 lb.ft)

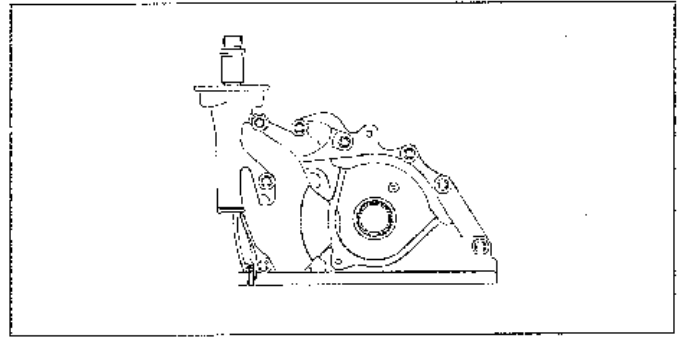

6. Install a balance shaft assembly to the cylinder block.

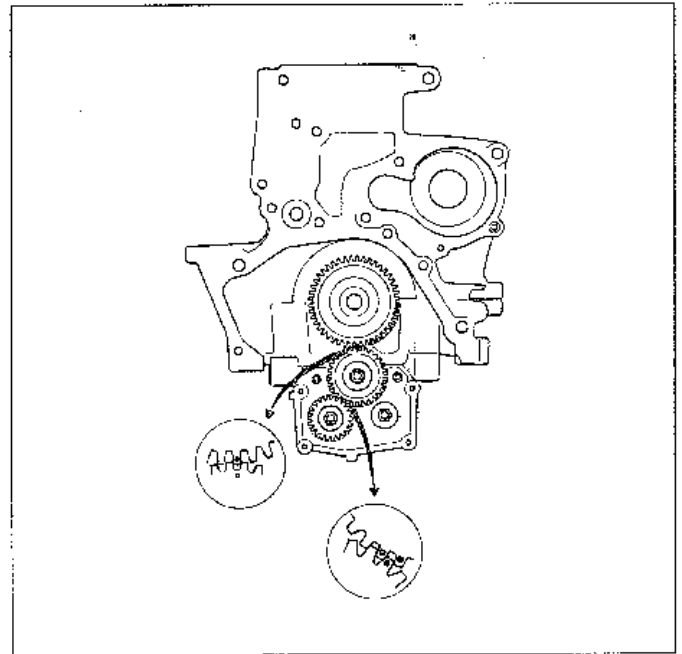

7. Apply sealant to the groove of the pan flange as shown.

NOTE

1. Apply sealant approximately 4 mm (0.16 in.) in thickness.
2. After the application of the sealant, install the oil pan within 15 minutes.

8. Install the oil pan and tighten the bolts to the specified torque.

Tightening torque

Oil pan bolt : 10-12Nm(100-120kg.cm, 7-9 lb.ft)

9. Using a 24 mm deep socket, install the oil pressure switch after applying sealant to the threaded area.

Sealant : Threebond 1104 or equivalent

 NOTE

Do not torque the oil pressure switch excessively.

Tightening torque

Oil pressure switch : 15-22Nm(150-220kg.cm,
11-16 lb.ft)

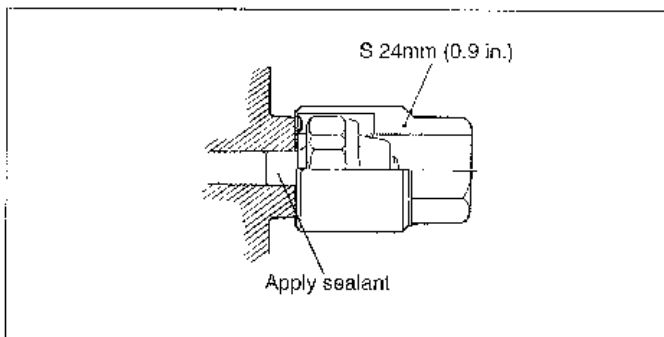

ECH-A263A

ENGINE AND TRANSAXLE ASSEMBLY

ENGINE AND TRANSAXLE ASSEMBLY

ECHB2300

REMOVAL

1. Remove the battery.
2. Detach the air cleaner.

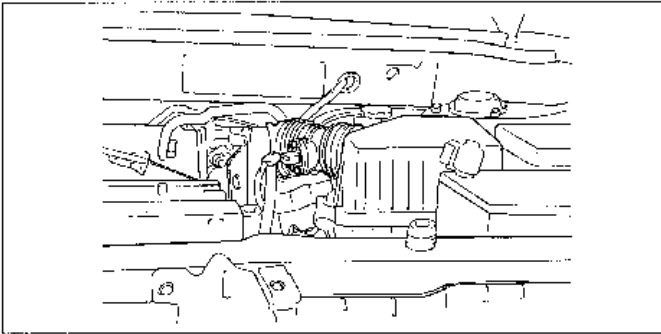

ECJA8703

3. Disconnect the engine harness connectors.
 1. Engine wiring connectors (alternator, starter, etc.)
 2. Power steering switch connector, oil pressure gauge connector.
 3. Back up lamp switch connector.
 4. A/T solenoid, inhibitor switch connector.
 5. Coolant temperature sensor.
 6. Oxygen sensor connector.

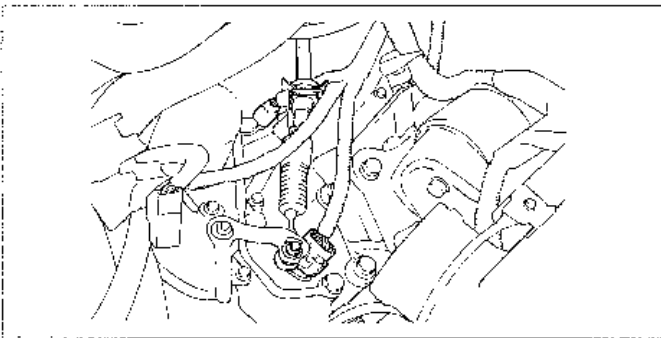

ECA9014A

4. Drain the engine coolant.
5. For a vehicle with automatic transaxles, disconnect the transaxle oil cooler hoses.

NOTE

- When disconnecting hoses, make identification marks to avoid making any mistake when installing them again.

CAUTION

- Be careful not to spill any of oil or fluid out of the hoses. Plug the openings to prevent the entry of foreign material.

6. Disconnect the radiator upper and lower hoses on the engine side then remove the radiator assembly.

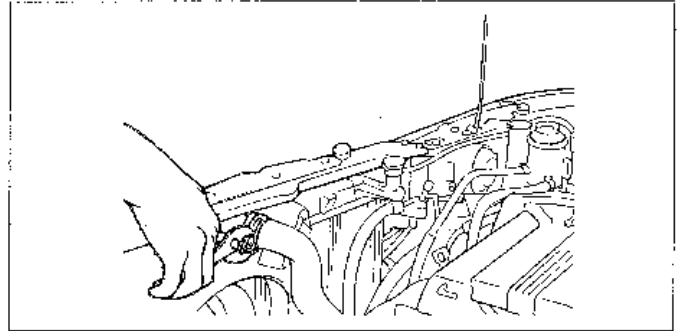

EDJA330A

7. Disconnect the engine ground.
8. Disconnect the brake booster vacuum hose.
9. Disconnect the heater hoses (inlet and outlet) on the engine side.
10. Using a special tool, remove the main fuel line at the common rail (supply/return).
11. Disconnect the speedometer cable from the transaxle.
12. Disconnect the clutch cable or control cable from the transaxle.

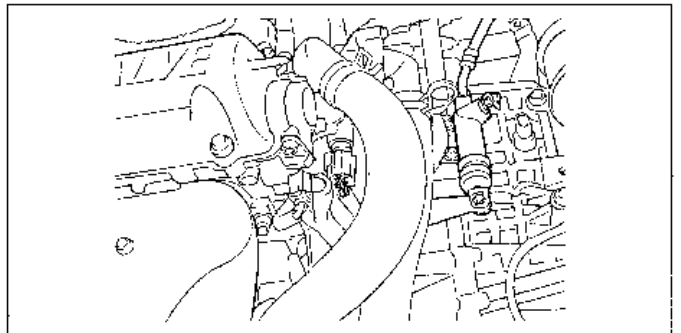

ECHA004N

- 13. Disconnect the power steering suction hose and return hose from the pump.

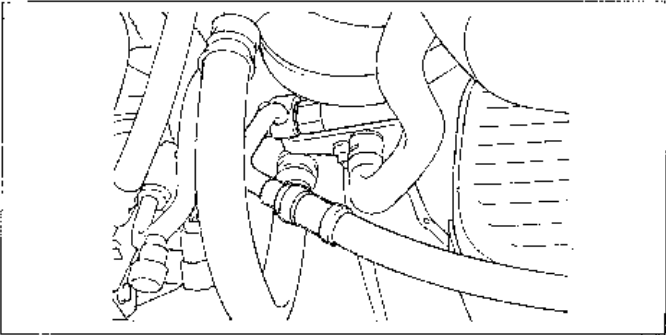

ECHA004H

- 14. Detach the steering dust cover in the engine compartment and then disconnect the gear box universal joint bolt.

NOTE

Make sure to make identification marks between the universal joint and the gear box for reassembly.

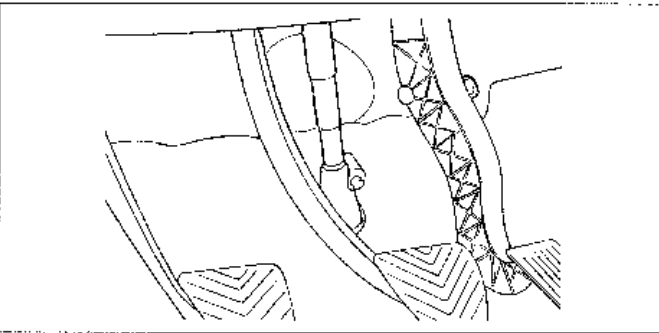

ECHA004I

- 15. Raise the vehicle and then remove the front tire.
- 16. Remove the calliper assembly from the knuckle. Tie it using wire, hang it from the suspension.

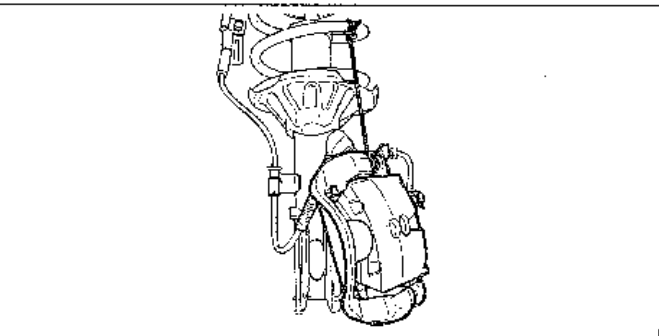

ECHA004J

- 17. Loosen the strut lower bolt and then remove it.

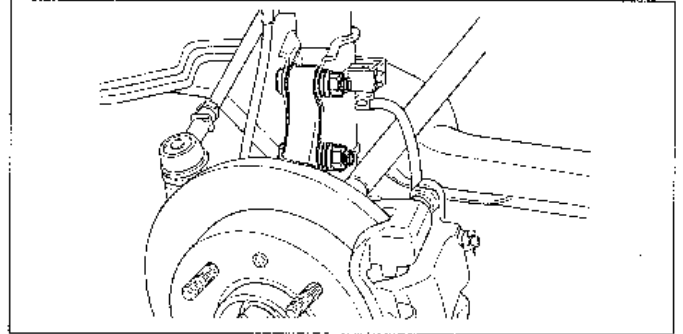

ECHA004K

- 18. Drain the transaxle oil.

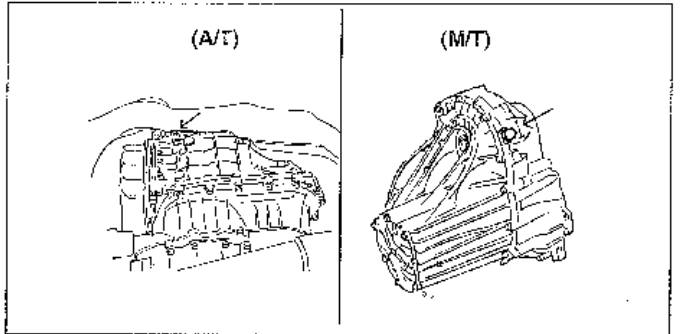

ECHA004Z

- 19. Remove the front muffler bolts.

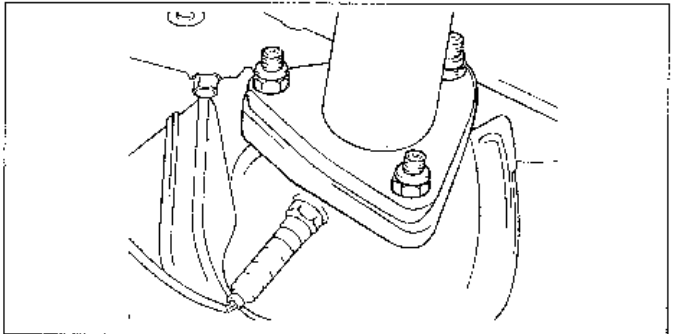

ECJA230B

- 20. Remove the transaxle control rod and extension rod (M/T only).

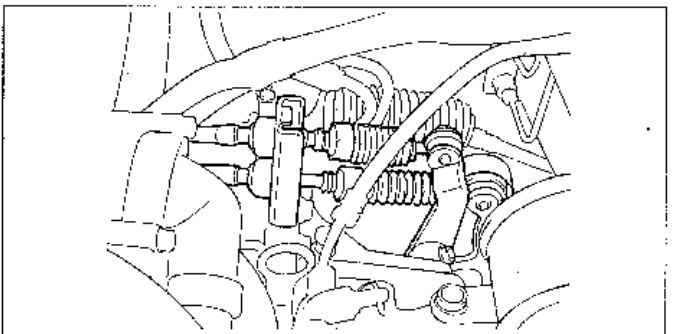

EDHA206F

- 21. Put the special fixture on the T/M jack and then adjust it to the sub-frame.

 **NOTE**

Check that all the cables, harness connector and hose are disconnected from the engine and transaxle assembly.

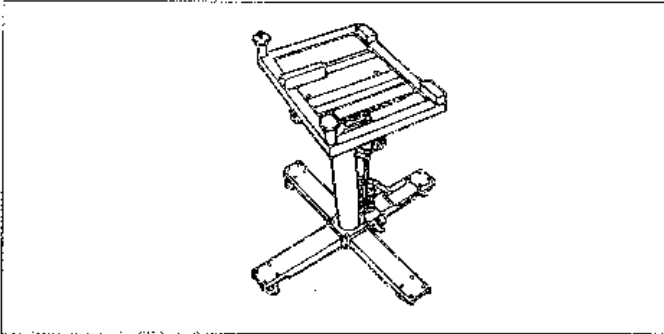

ECHA004C

22. Remove the engine mounting bracket and the transaxle mounting bracket.

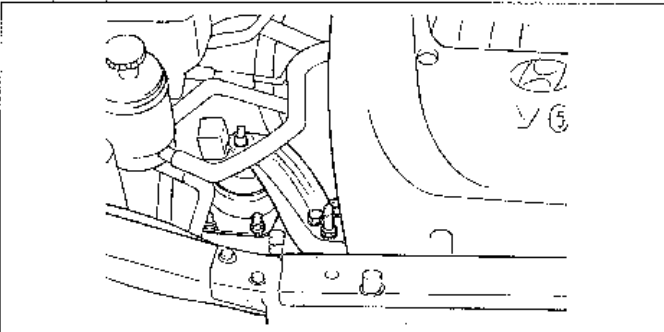

EDHA004A

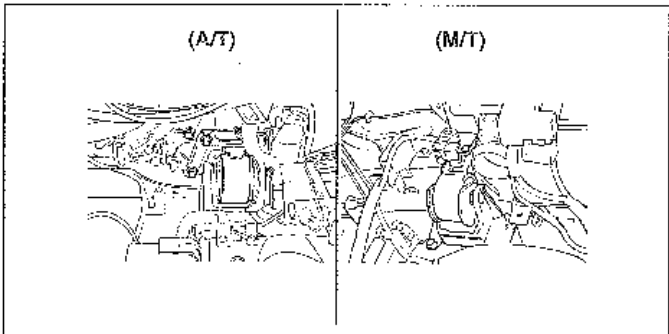

EDHA004C

23. Remove the sub-frame installation bolts.

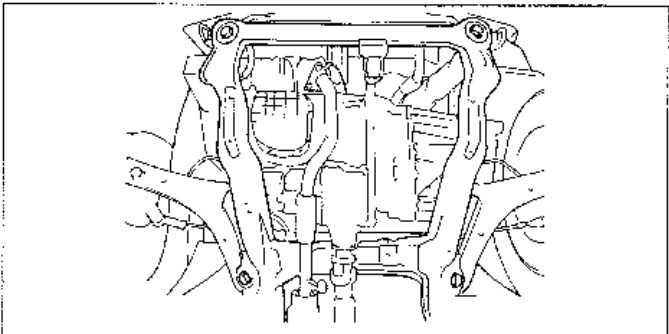

EDJA230C

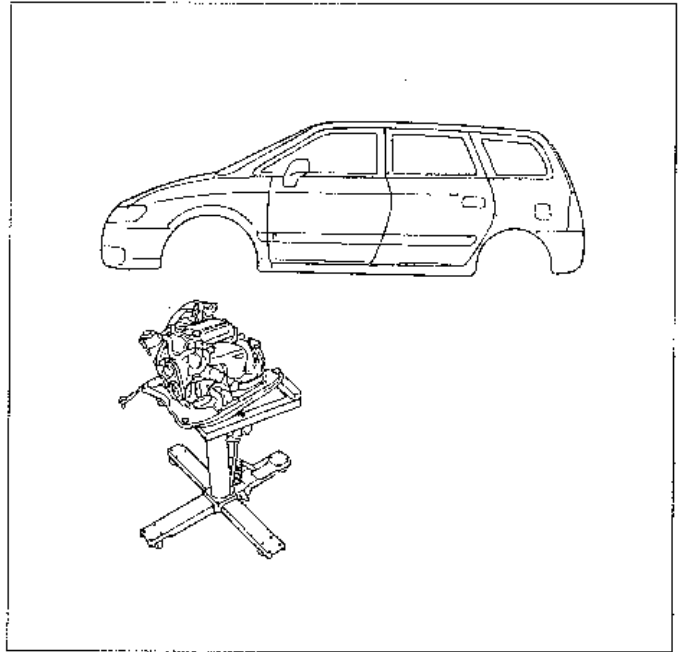

EDHA006I

24. After removing the drive shaft, lower the engine and transaxle assembly on the jack then, remove the front roll stopper and the rear roll stopper.

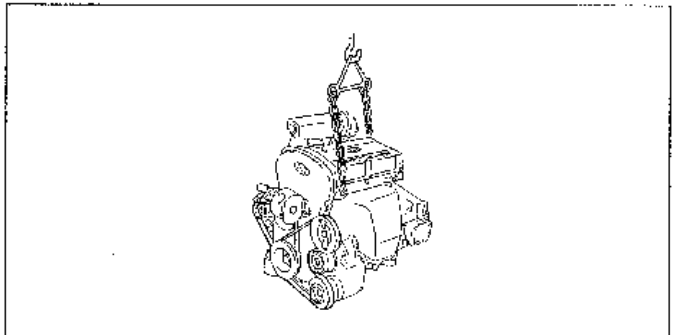

ECA9021A

25. Remove the engine and transaxle assembly as a unit.

INSTALLATION FCJA2400

1. When installing the engine and transaxle, check the connections of harnesses, pipes, hoses, etc. make sure that none of them are caught, damaged, etc.
2. Install the front roll stopper to the bracket roughly.

Tightening torque

Service standard : 50-65 Nm (500-650kg.cm, 36-47 lb.ft)

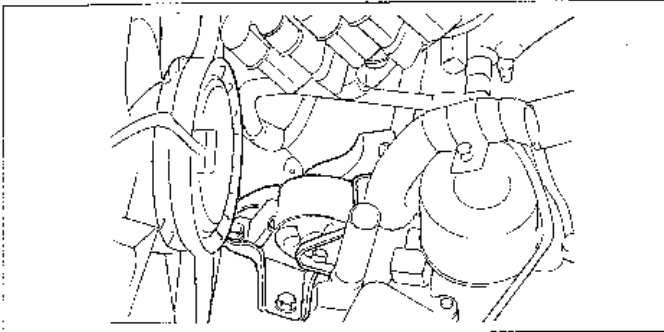

ECHA005A

3. Install the rear roll stopper to the bracket.

Tightening torque

Service standard : 50-65Nm(500-650kg.cm, 36-47 lb.ft)

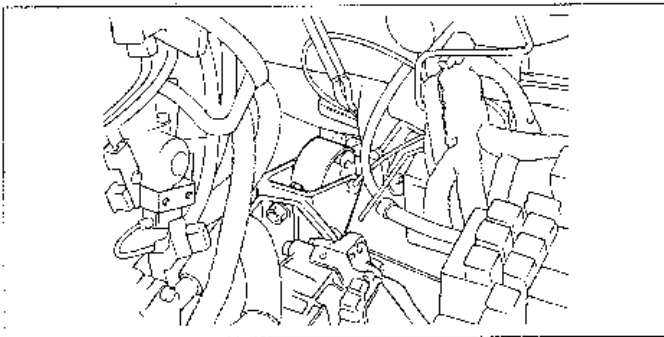

ECHA005B

4. Install the engine/transaxle to the sub-frame assembly. Use the T/M jack to raise the assembly slowly adjust it to the vehicle body.

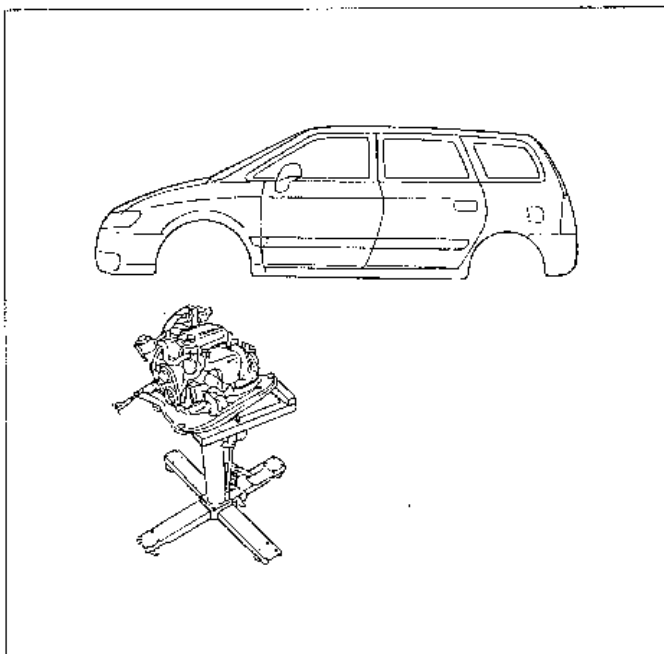

EDF/ACC8I

5. Install the transaxle mounting bracket.

Tightening torque

Service standard : 90-110Nm(900-1100kg.cm, 65-80 lb.ft)

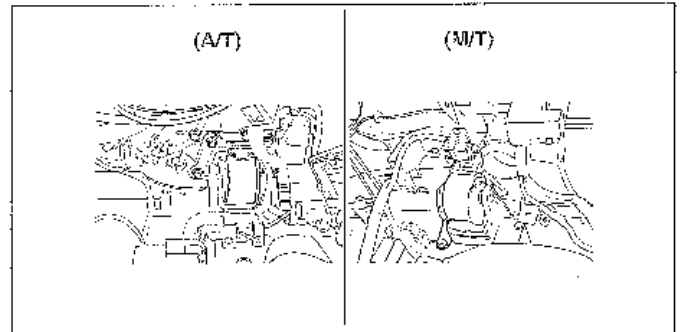

ECHA004C

6. Install the engine bracket (right side).

Tightening torque

Service standard : 60-80Nm(600-800kg.cm, 43-58 lb.ft)

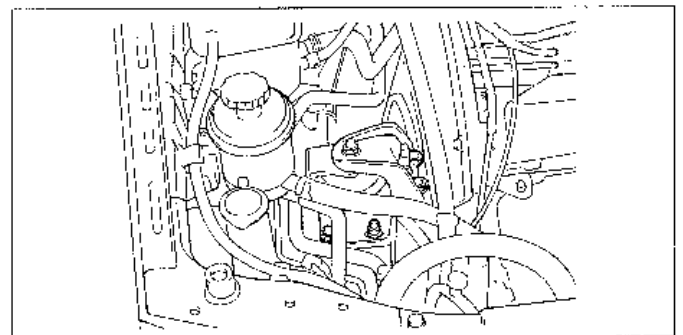

ECHA005E

7. To install all of parts, follow the removal procedures in the reverse order.
8. Refill the coolant and then check for leaks.
9. Refill the transaxle oil and check for leaks, then test its operation.
10. Check the operation of the transaxle control cable and accelerator cable.
11. Check the proper operation of each gauge.

MAIN MOVING SYSTEM

CAM SHAFT

COMPONENTS ECH83000

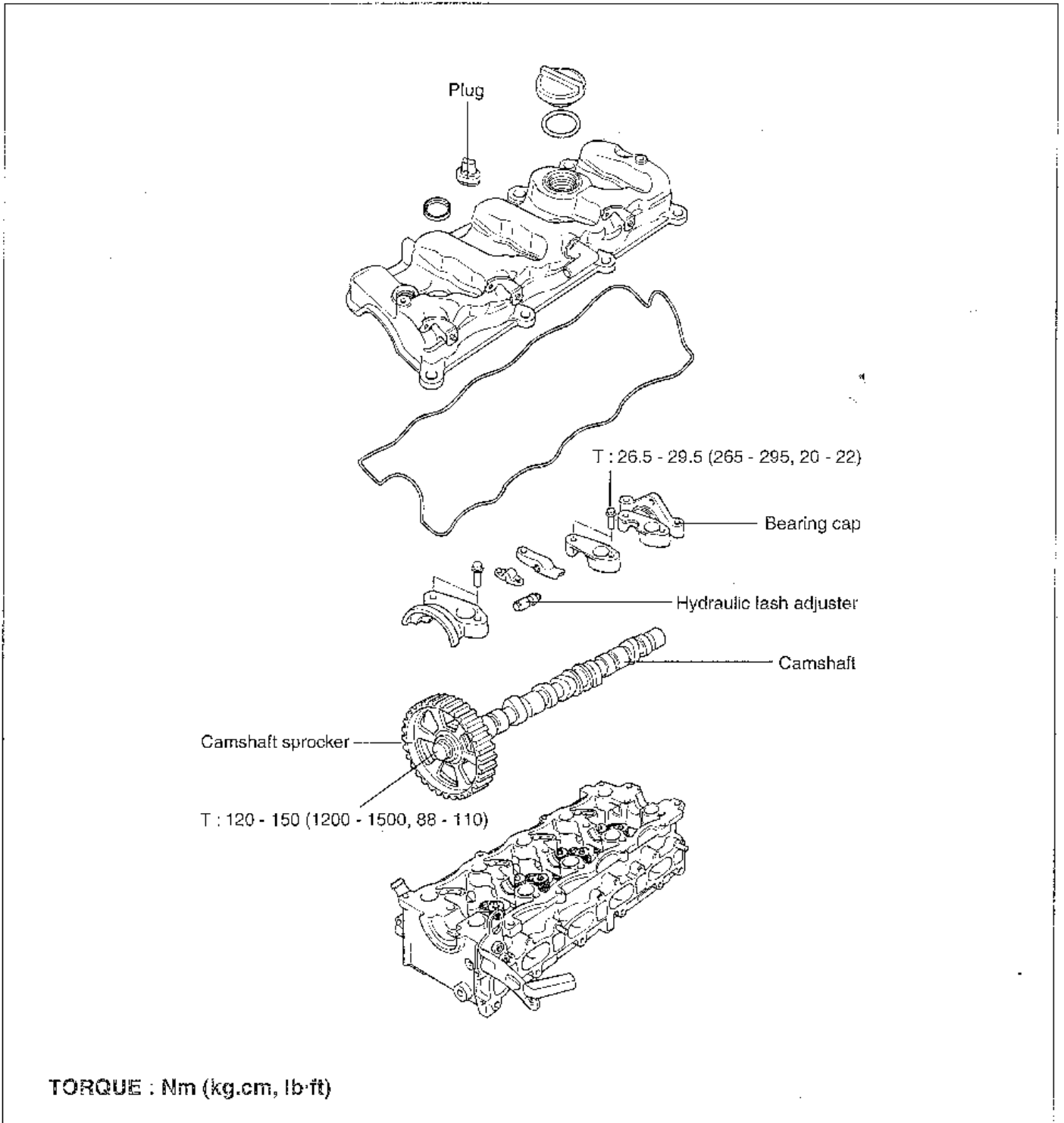

TORQUE : Nm (kg.cm, lb.ft)

DISASSEMBLY ECHB5100

1. Disconnect the negative terminal from the battery.
2. Drain the engine coolant.
3. Remove the breather hose between the air cleaner and the rocker cover.
4. Remove the air cleaner.
5. Remove the timing belt cover.
6. Remove the rocker cover and crank shaft position sensor.
7. Loosen the camshaft sprocket bolts then remove the camshaft sprockets.
8. Loosen the camshaft bearing cap bolts and remove the bearing caps, camshafts, rocker arms and lash adjusters.

WARNING**REMOVAL AND INSTALLATION OF INJECTOR AND HIGH PRESSURE PUMP.**

1. Fuel system is subject to extremely high pressure (1350 bar).
2. Never perform any work on injection system with engine running or within 30 seconds after stopping the engine.
3. Always pay attention to safety precautions.
4. Ensure the absolute cleanliness.
5. Never remove the injectors.

INSPECTION ECHB3200**ROCKER ARMS**

1. Check rotation of the roller. If they do not rotate smoothly or are loose, replace them.
2. Check the roller surface. Replace if there is any dent, damage or evidence of seizure.

3. Check the valve contact surface for possible damage or evidence of seizure. Replace if necessary.

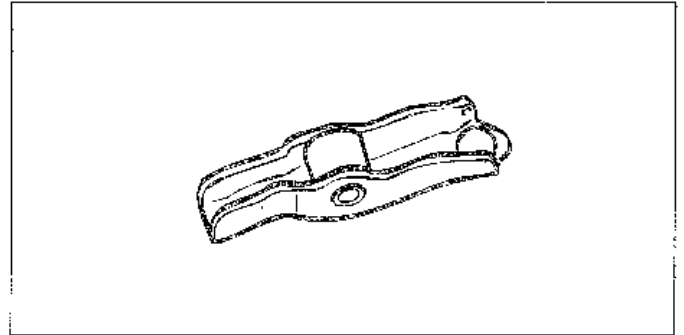

KCI1B013B

CAMSHAFTS

1. Check the camshaft journals for wear. If the journals are badly worn, replace the camshaft.
2. Check the cam lobes for damage. If the lobe is damaged or worn excessively, replace the camshaft.

Cam height

[Standard]

Intake : 34.697 mm (1.366 in.)

Exhaust : 34.570 mm (1.361 in.)

[Limit]

Intake : 34.197 mm (1.346 in.)

Exhaust : 34.070 mm (1.341 in.)

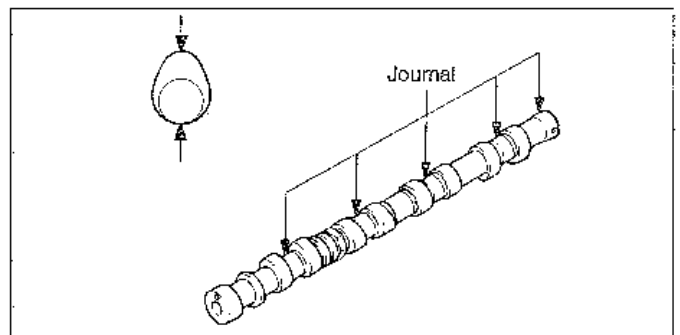

ECA9240B

REASSEMBLY ECH63300

1. Install the camshafts on the cylinder head.

NOTE

Apply engine oil to journals and cams of the camshafts.

2. Install the bearing caps.
3. Check that the camshaft can be easily turned by hand. After checking, remove the bearing caps and the camshafts, and then install the rocker arms.
4. Make sure that the dowel pins on the camshaft sprocket ends are located on the top.

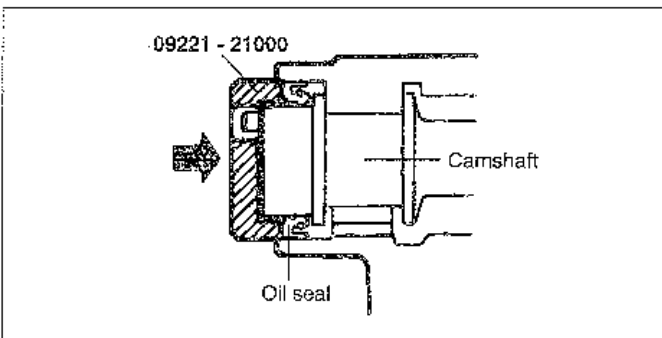

ECLA019E

5. Tighten the bearing caps to the specified torque in two or three increments as shown.

NOTE

Tighten the rocker arms uniformly.

Tightening torque

Bearing cap bolts:

27 - 30 Nm (270 - 300 kg.cm, 20 - 22 lb.ft)

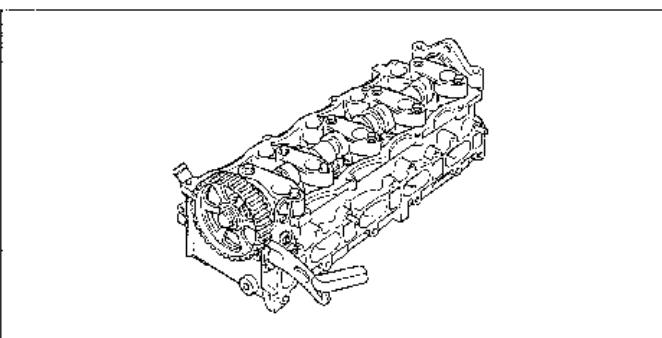

KCH6013D

6. Using the special tools, camshaft oil seal installer. Be sure to apply engine oil to the external surface of the oil seal. Insert the oil seal along the camshaft front end and install it by driving the installer with a hammer until the oil seal is fully seated.

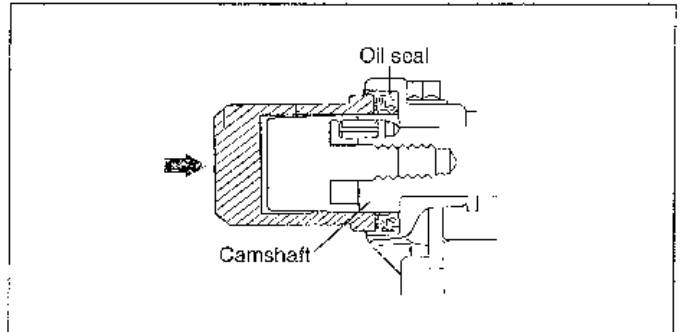

KCHA330C

7. Install the camshaft sprocket bolts to the specified torque.

Tightening torque

Camshaft sprocket bolts :

120 - 150 Nm (1200 - 1500 kg.cm, 88 - 110 lb.ft)

8. Install the rocker cover.

Tightening torque

Rocker cover bolts : 10-14 Nm (100-140 kg.cm, 7-10 lb.ft)

CRANK SHAFT

COMPONENTS ECHID4000

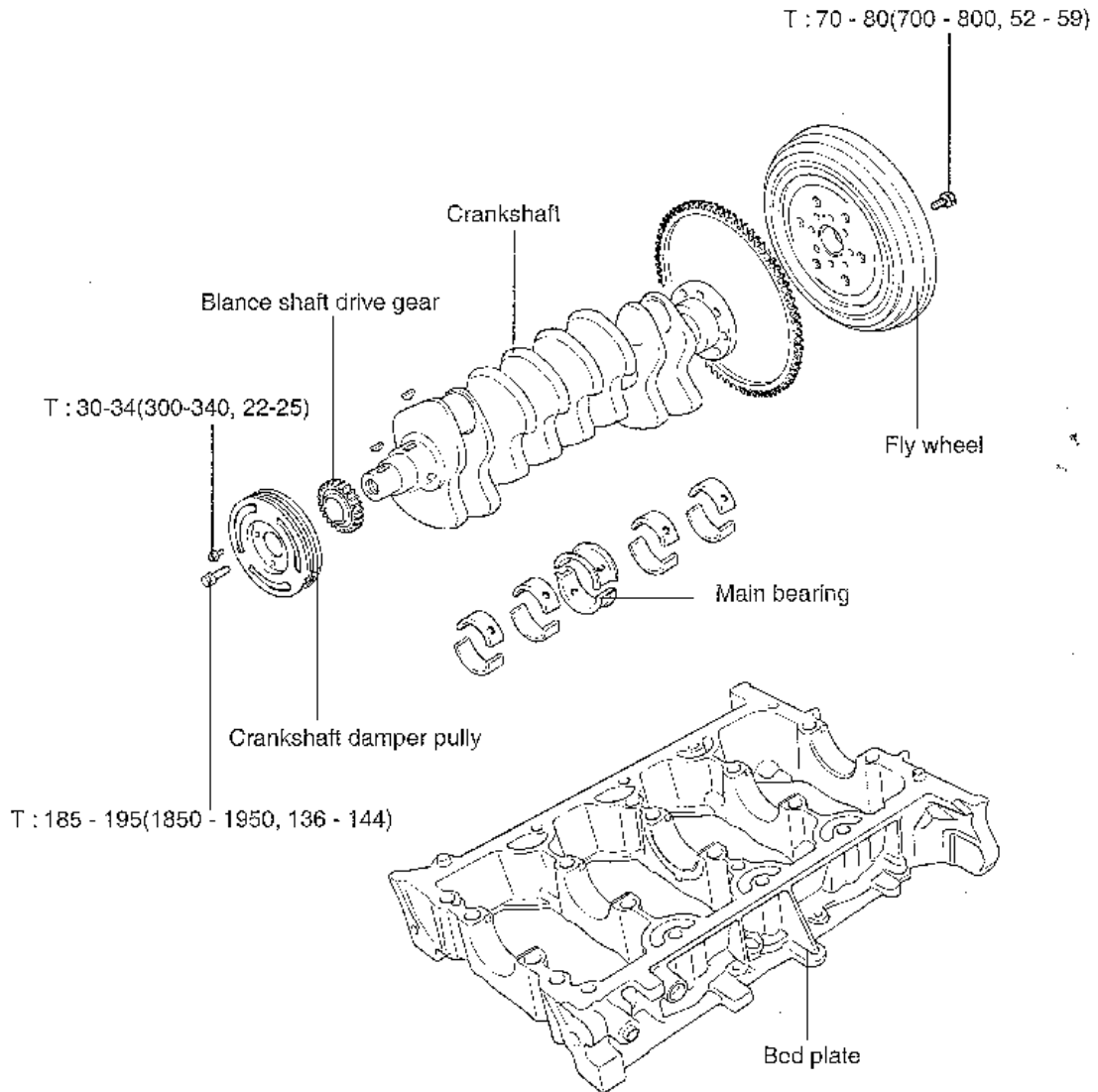

TORQUE : Nm (kg.cm, lb-ft)

DISASSEMBLY ECHB4130

1. Remove the timing belt, front case, flywheel, cylinder head assembly and oil pan. For details, refer to the respective chapters.
2. Remove the rear plate and the rear oil seal.
3. Remove the connecting rod caps.

NOTE

Mark the main bearing caps to be able to reassemble in the original position and direction.

4. Remove the bedplate and the crankshaft. Keep the bearings in order according to the cap number.

INSPECTION ECHB4200

CRANKSHAFT

1. Check the crankshaft journals and pins for damage, uneven wear and cracks. Also check the oil holes for restrictions. Repair or replace any defective part.
2. Inspect the crankshaft journal for taper and out-of-round.

Standard value

- Crankshaft journal O.D :
- 60.002 - 60.020 mm (2.362 - 2.363 in.)
- Crankshaft pin O.D :
- 50.008 - 50.026 mm(1.969 - 1.9695 in.)

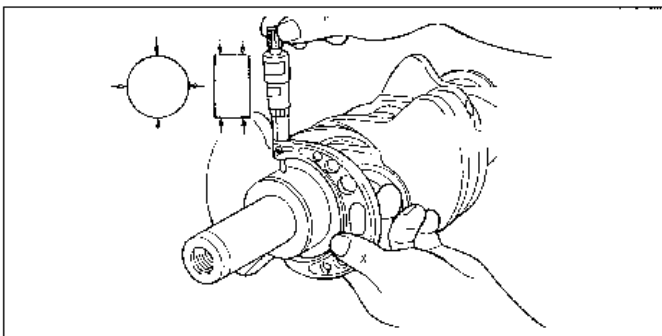

MAIN BEARINGS AND CONNECTING ROD BEARINGS

Visually inspect each bearing for peeling, melting, seizure and improper contact. Replace any defective bearings.

MEASURING OIL CLEARANCE

Check the oil clearance by measuring the outside diameter of the crankshaft journal as well as the the inside diameter

of the bearing. The clearance can be obtained by calculating the difference between the measured diameters.

Standard value

- Oil clearance
- Crankshaft main bearing :
- 0.024 - 0.042 mm (0.0009 - 0.0017 in.)
- Connecting rod bearing :
- 0.024 - 0.042 mm (0.0009 - 0.0017 in.)
- Limit : 0.1 mm (0.0039 in.)

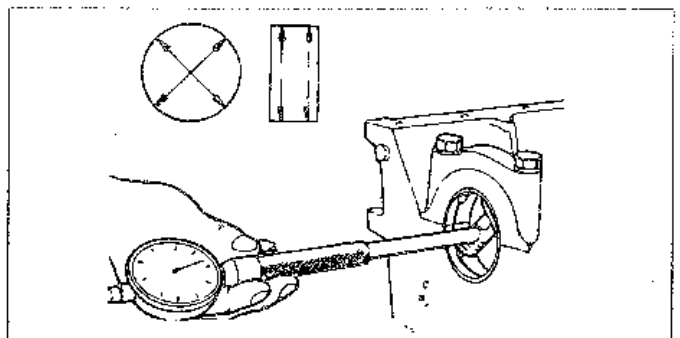

HOW TO USE PLASTIGAUGE

Plastigauge may be used to measure the clearance.

1. Remove oil, grease and any other dirt from the bearings and journals.
2. Cut the plastigauge to the same length as the width of the bearing and place it in parallel with the journal, avoiding the oil holes.
3. Install the crankshaft, bearings and caps and tighten them to the specified torques. During this operation, do not turn the crankshaft. Remove the caps. Measure the width of the plastigauge at the widest part by using the scale printed on the gauge package. If the clearance exceeds the service limit, the bearing should be replaced or an undersize bearing should be used. When installing a new crankshaft, be sure to use standard size bearings. If the standard clearance can not be obtained even after replacing the bearing, the journal and pin should be ground to thr undersize and a bearing of the corresponding size should be installed.

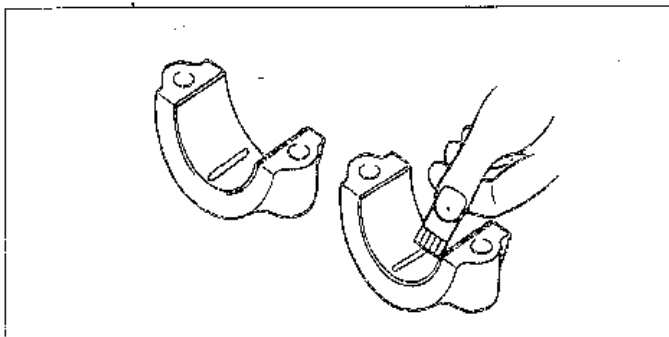

ECA9410C

OIL SEAL

Check the front and rear oil seals for damage or worn surfaces. Replace any seal that is defective.

BEDPLATE

After installing the bedplate, make sure the crankshaft turns smoothly and the end play is correct. If the end play exceeds the limit, replace the crankshaft bearings.

Standard value: 0.09 - 0.32 mm (0.0035 - 0.026 in.)

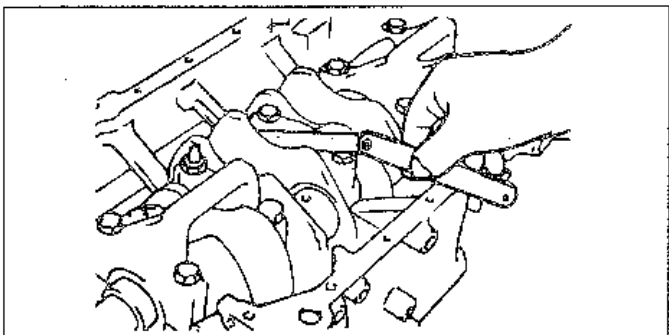

ECA9410D

DRIVE PLATE (A/T)

Replace distorted, damaged, or cracked drive plates.

FLYWHEEL (M/T)

1. Check the clutch disc contacting surface of the flywheel for damage and wear. Replace the flywheel if excessively damaged or worn.
2. Check the clutch disc contacting surface of the flywheel for run-out.

Limit

Flywheel run-out : 0.13mm(0.0051 in.)

3. Check the ring gear for damage, cracks and wear. Replace if necessary.

REASSEMBLY EC-H34300

1. Install a grooved main bearing (upper bearing) on the cylinder block side.
2. Install a grooveless main bearing (lower bearing) on the main bearing cap side.
3. Lower center thrust bearing is grooveless. Upper center thrust bearing is grooved.

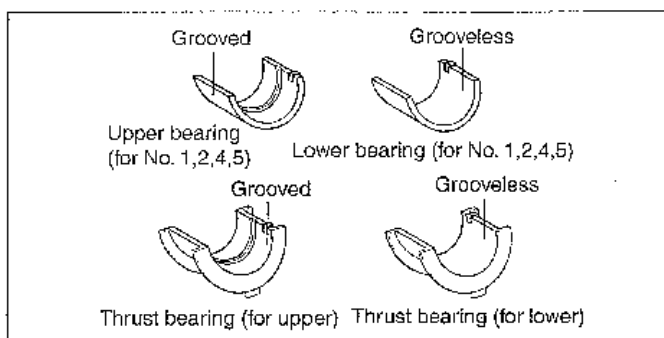

KCHB005C

4. Apply engine oil to journals and pins. Install the crankshaft.
5. Install the bedplate with the arrow mark directed toward the front of the engine.
6. Tighten the cap bolts to the specified torque.

Tightening torque

Main bearing cap bolts :

15 mm : 25 Nm (250 kg-cm, 18lb-ft) + (90°)

12 mm : 33 - 37 Nm (330 - 370 kg-cm, 24 - 27 lb-ft)

7. Cap bolts should be tightened evenly in 4 to 5 increments before they are tightened to the specified torque.
8. Make sure that the crankshaft turns freely and check the end play of the crankshaft.

- Using a special tool (09231 - 27000). Install the oil seal in the oil seal case. A new oil seal should be used.

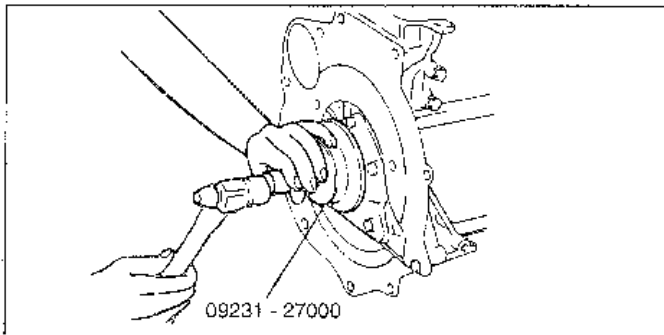

ECH8014Z

<For M/T>

- Install the rear plate to the cylinder block.
- Install the flywheel assembly and tighten the bolts to the specified torque.

Tightening torque

Flywheel bolt :

70 - 80 Nm (700 - 800kg.cm, 52 - 59 lb.ft)

<For A/T>

- Install the adapter plate to the cylinder block.
- Install the drive plate and tighten the bolts to the specified torque.

Tightening torque

Drive plate : 70 - 80 Nm (700 - 800kg.cm, 52 - 59 lb.ft)

PISTON

COMPONENTS ECHB3500

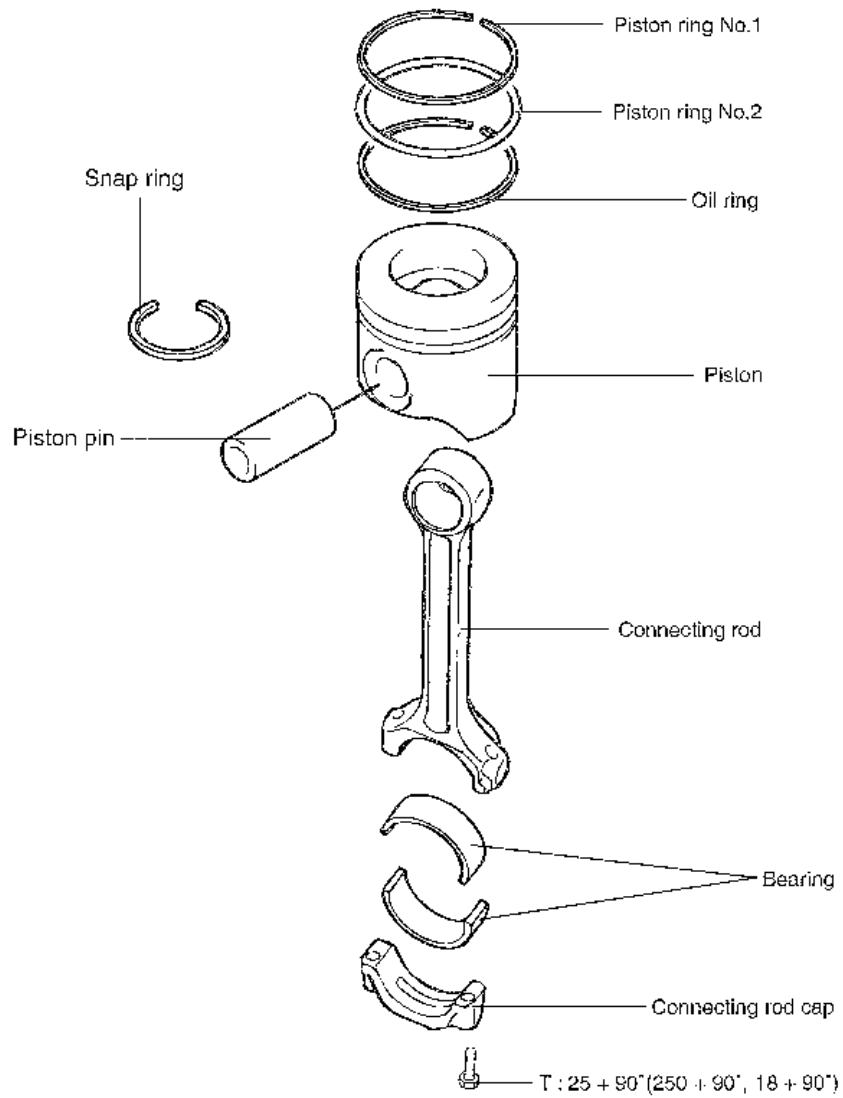

TORQUE : Nm (kg.cm, lb-ft)

INSPECTION ECH93600

PISTON

1. Check each piston for scuffing, scoring, wear and other defects. Replace any piston that is defective.
2. Check that the piston pin fits in the piston pin hole. Replace any piston and pin assembly that is defective. The piston pin must be smoothly pressed by hand into the pin hole (at room temperature)

PISTON RING

1. Check each piston ring for breakage, damage and abnormal wear. Replace the defective rings.
2. When the piston requires replacement, its ring should also be replaced.
3. Measure the clearance between piston ring and ring home.

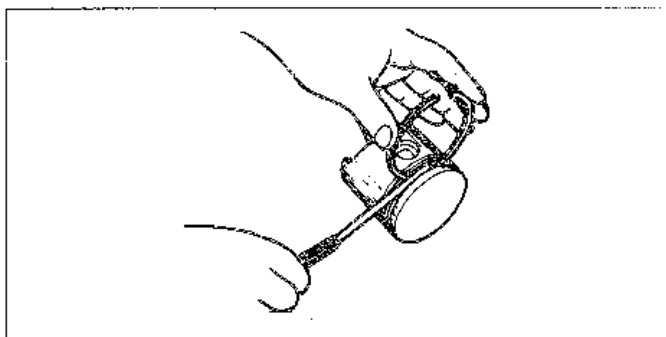

ECLAC10B

Standard Value : Ring - to - ring groove clearance

No. 2 : 0.065 - 0.11 mm (0.00256 - 0.00433 in.)

Oil ring : 0.03 - 0.07 mm (0.00118 - 0.00275 in.)

4. Place a piston ring in the cylinder bore and set it square by pushing it down with piston.
5. Measure the end clearance using a thickness gauge.

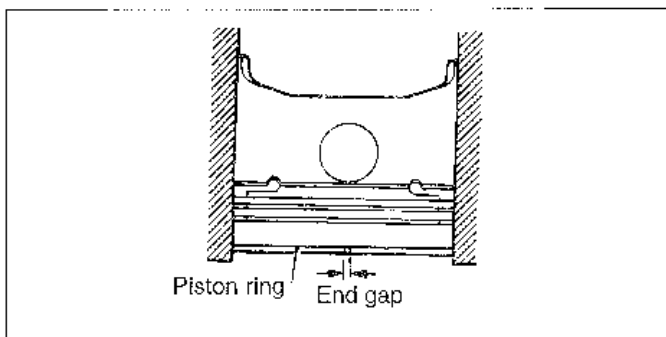

ECLA010D

Standard Value : End gap

No. 1 : 0.2 - 0.3 mm (0.0079 - 0.0118 in.)

No. 2 : 0.30 - 0.45 mm (0.0118 - 0.0177 in.)

Oil ring : 0.2 - 0.45 mm (0.0079 - 0.0177 in.)

Limit : 0.8 mm (0.0315 in.)

CONNECTING ROD BEARING

1. Check the bearing surfaces for uneven contact pattern, streaks, scratches, and seizure. If defects are evident, replace. If the surfaces are seriously nicked and seized, check also the crankshaft. If the crankshaft is also damaged, replace the crankshaft or grind to undersize for reuse.

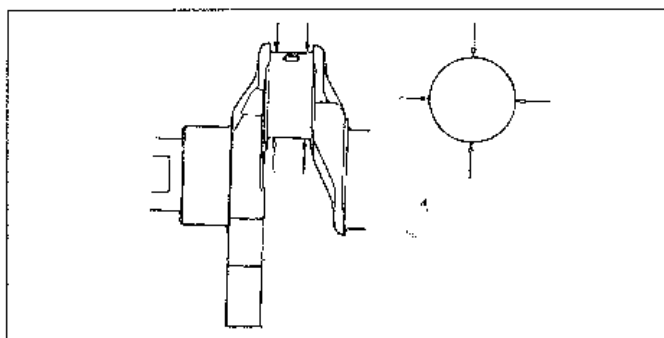

ECLA010E

2. Measure the connecting rod bearing I.D. and crankshaft pin O.D. If the clearance (oil clearance) exceeds the limit, replace the bearing and, if necessary, the crankshaft. Or, grind the crankshaft to an undersize and, at the same time, replace the bearing with an undersize.

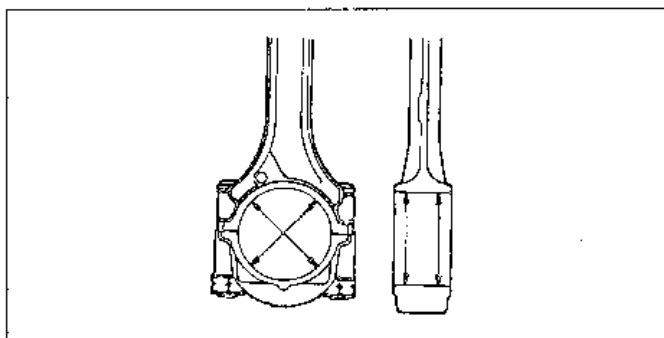

ECLA010F

Standard value :

0.024 - 0.042 mm (0.0009 - 0.0016 in.)

Limit : 0.10 mm (0.0039 in.)

INSTALLATION ECHB3700

CONNECTING ROD, PISTON PIN AND PISTON

1. Match the piston with the connecting rod.
2. Line up the front marks and insert the piston pin. The piston pin must be smoothly pressed by hand into position. Replace the piston pin if there is excessive play.

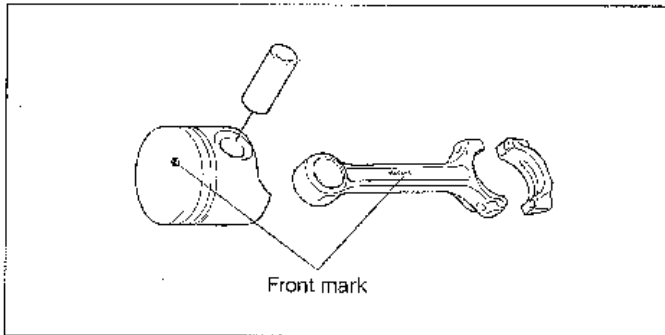

XCHB006B

PISTON RING

1. Install the oil ring expander and oil ring to the piston. Then, install No.2 piston ring and No.1 piston ring, in that order. Make sure that the ring side, on which manufacturer and size marks are stamped, faces to the piston crown.

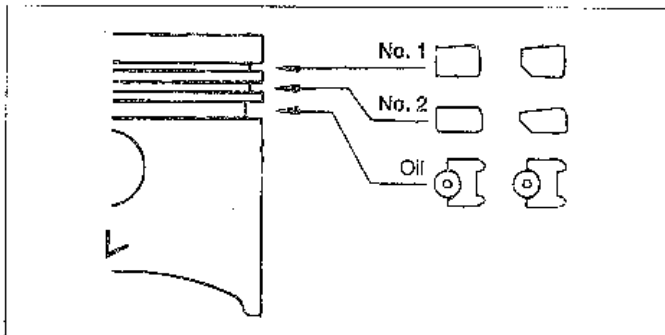

ECLA010L

2. Position ends of piston and oil (side rail, spacer) rings as illustrated.

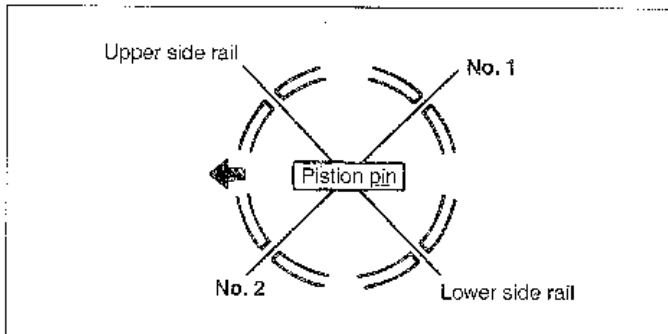

ECLA010M

3. Insert the piston and connecting rod assembly from above the top of cylinder. Ensure that the front mark on piston crown and that (ID mark) on the connecting rod face toward the front of engine (to the crank pulley side).
4. Clamp firm the piston rings with the ring band and install the piston assembly into cylinder. Do not strike it hard into the piston, as broken piston ring or damaged crank pin could result.

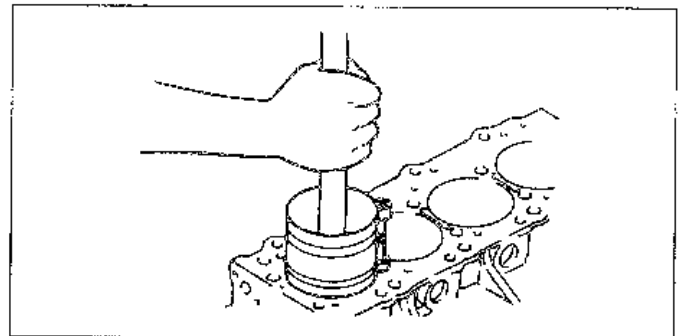

ECLA010N

5. Tighten the connecting rod cap bolts.

Tightening torque

Connecting rod cap bolts :

25 Nm (250 kg·cm, 18·4 lb·ft) + 90°

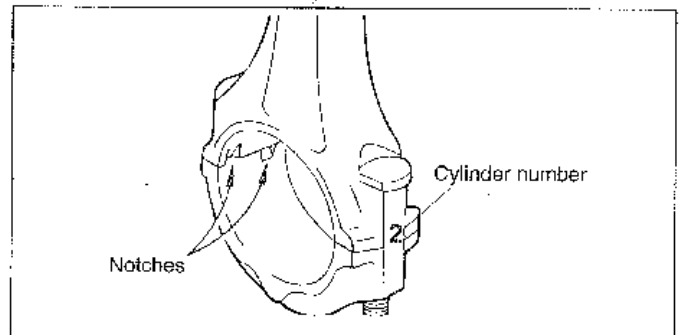

ECA9360A

NOTE

Re-use of the bolt must be limited to 3 times.

6. Make sure the clearance of connecting rod big end side.

Standard Value : 0.10 - 0.35 mm (0.0039 - 0.0138 in.)

Limit : 0.4 mm (0.0157 in.)

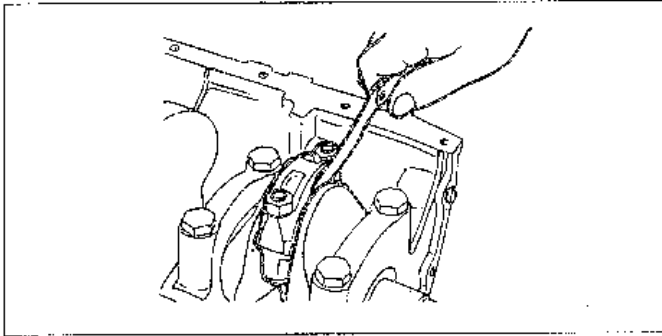

ECl A0100

COOLING SYSTEM

ENGINE COOLANT HOSE/PIPES

COMPONENTS ECHB4500

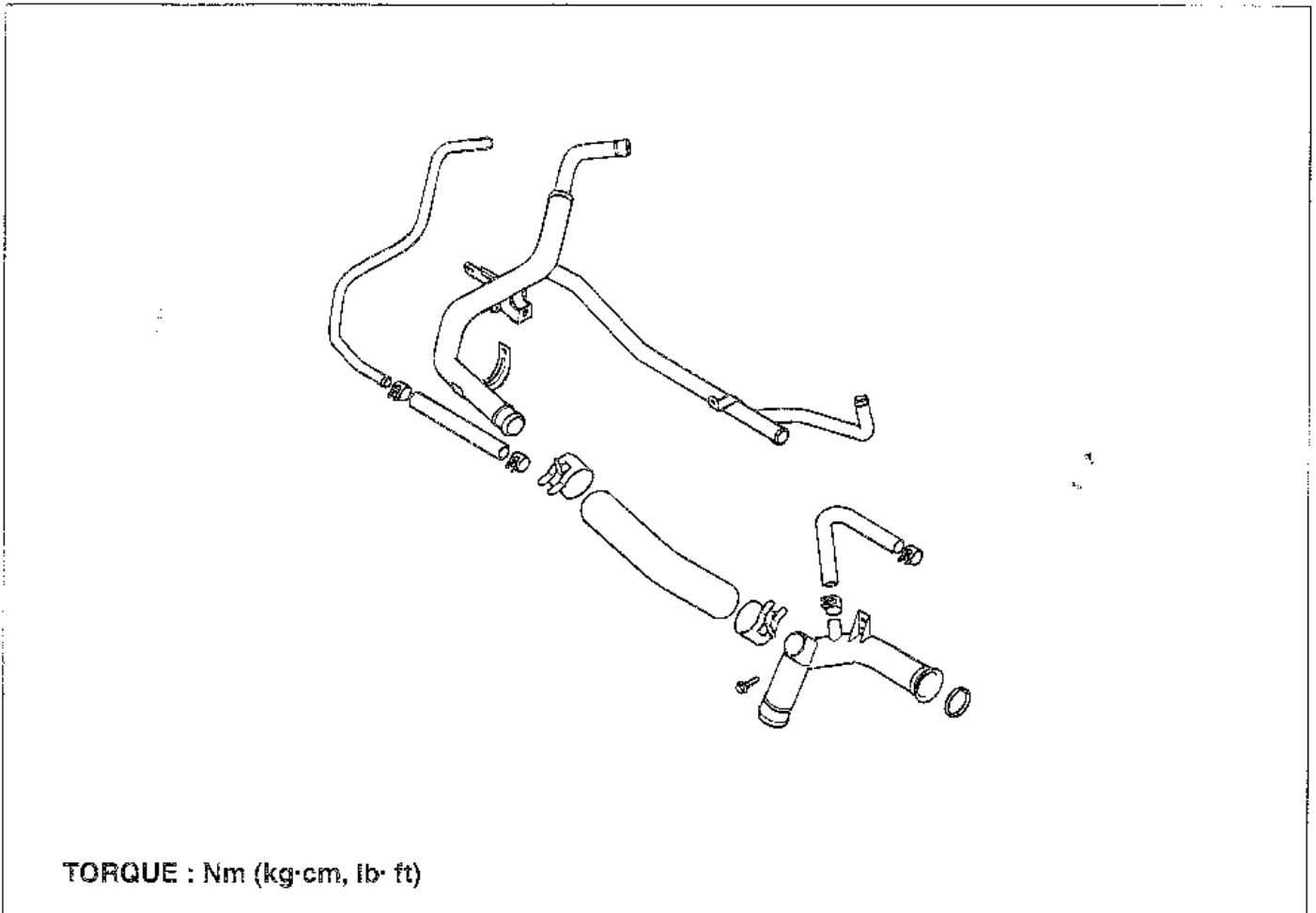

KCH-B007C

INSPECTION ECHA4200

Check the engine coolant pipe and hose for cracks, damage and restrictions. Replace if necessary.

REASSEMBLY ECHA4700

Fit an O-ring in the groove provided at the engine coolant inlet pipe end. Wet the periphery of the O-ring with water and insert the engine coolant inlet pipe.

 **NOTE**

1. Do not apply oil or grease to engine coolant pipe O-ring.
2. Keep the engine coolant pipe connections free of sand, dust, etc.
3. Insert the engine coolant pipe into the end of the engine coolant pump inlet.
4. Whenever installing the engine coolant inlet pipe, always replace the O-ring with a new one.

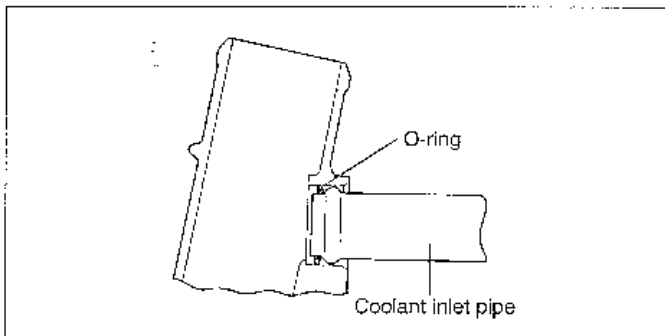

ECA9570A

COOLANT TEMPERATURE SENSOR ECHB5000

REMOVAL

1. Drain the coolant to a level below the bottom of the sensor.
2. Disconnect the ground cable from the battery and then remove the sensor connector.
3. Remove the coolant sensor.

INSTALLATION ECJA4900

1. Tighten the coolant temperature sensor to the specified torque after applying the sealant to the screw area.

Recommended sealant :

Threebond No. 1324N or LOCTITE 262

Tightening torque

The coolant temperature sensor :

20-40Nm (200-400 kg.cm, 14-29 lb.ft)

2. Connect the sensor to the harness.
3. Connect the ground cable to the battery.
4. Refill the engine coolant.

ENGINE COOLANT PUMP

COMPONENTS ECH85500

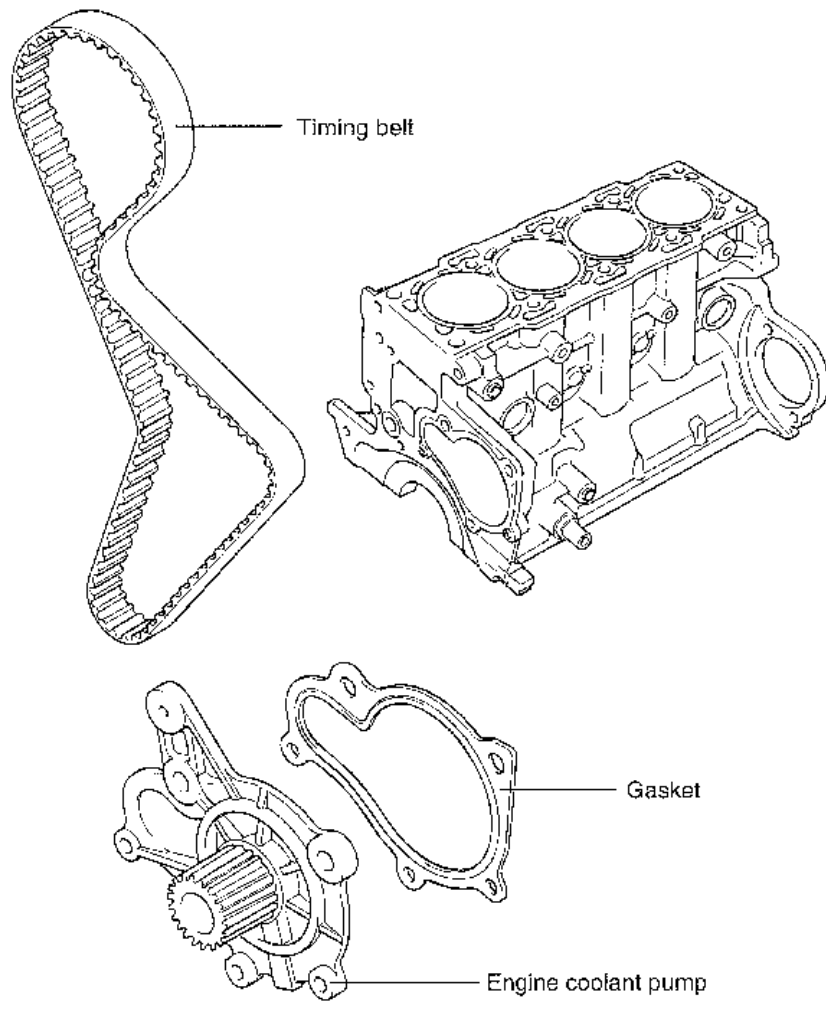

TORQUE : Nm (kg.cm, lb-ft)

REMOVAL ECHB5600

1. Drain the coolant and disconnect the coolant pump inlet pipe.
2. Remove the drive belt and engine support bracket.
3. Remove the timing belt covers and the timing belt tensioner.
4. Remove the engine coolant pump mounting bolts.
5. Remove the engine coolant pump assembly from the cylinder block.

INSPECTION ECHB5700

1. Check the pump for cracks, damage or wear. Replace the pump assembly if necessary.
2. Check the bearing for damage, abnormal noise, and sluggish rotation. Replace the pump assembly if necessary.
3. Check the seal for leaks. Replace the pump assembly if necessary.
4. Check for engine coolant leakage. If the engine coolant leaks, the seal is defective. Replace the engine coolant pump assembly.

INSTALLATION ECHB5800

1. Clean the gasket surfaces of the engine coolant pump body and the cylinder block.
2. Install the new O-ring onto the groove on the front end of the engine coolant pipe, then wet the O-ring with water. Do not apply oil or grease.

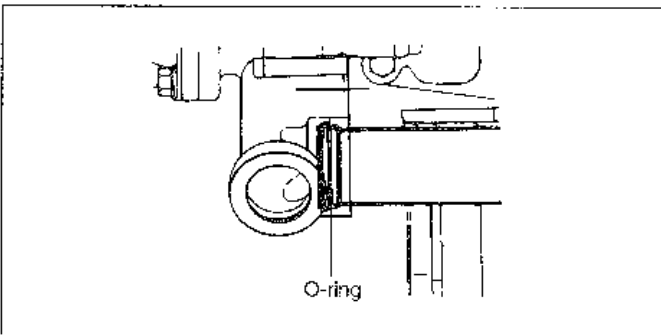

EC-1A013A

3. Install a new engine coolant pump gasket and engine coolant pump assembly. Tighten the bolts to the specified torque.

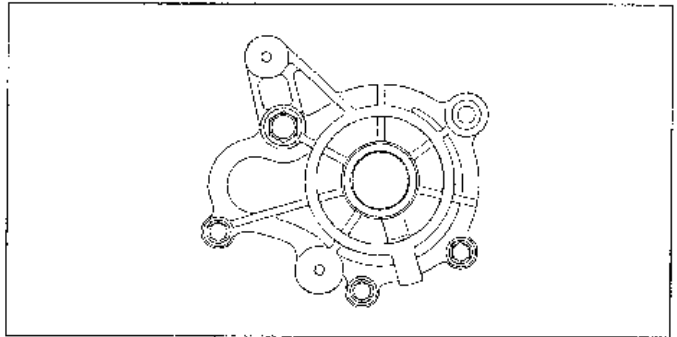

KCF-B007B

Tightening torque

Engine coolant pump bolt :

10 mm : 10 - 12 Nm (100 - 120kg-cm, 7 - 9 lb-ft)

14 mm : 48 - 52 Nm (480 - 520 kg-cm, 35 - 38lb-ft)

4. Install the timing belt tensioner and timing belt. Adjust the timing belt tension, then install the timing belt covers.
5. Refill the coolant.
6. Run the engine and check for leaks.

RADIATOR

COMPONENTS EC-B6000

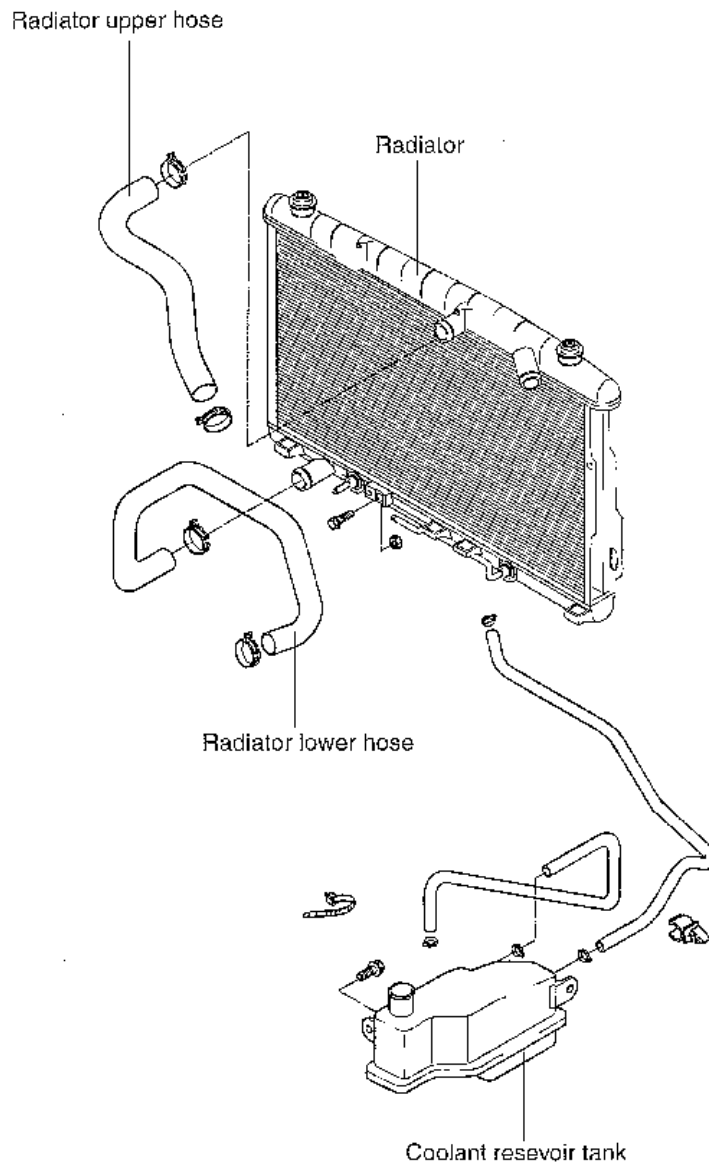

TORQUE : Nm (kg.cm, lb-ft)

REMOVAL ECJA5600

1. Disconnect the ground cable from the battery terminal.
2. Disconnect the fan motor connector.
3. Loosen the radiator drain plug to drain the coolant.
4. Disconnect the upper and lower hoses and overflow tube after making marks on the radiator hose and the hose clamp, to ease reassembly.

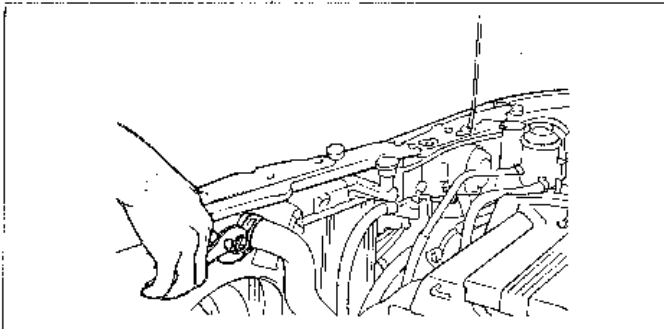

EDJA33CA

5. For vehicles with automatic transaxles, disconnect the oil cooler hoses from the automatic transaxle.

CAUTION

Cover or plug the hose and inlets of the radiator so that dust and other foreign materials can not enter after the hose is disconnected from the radiator.

6. Remove the radiator upper mounting bolt.

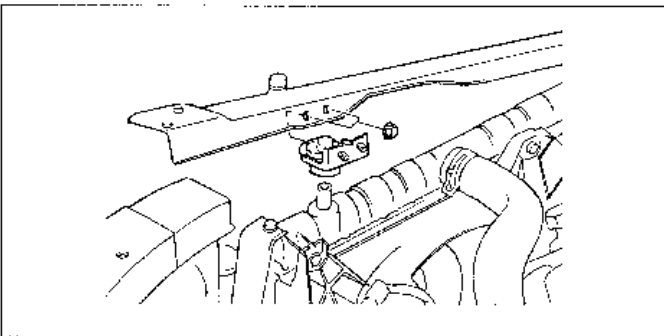

EDHA001C

7. Remove the radiator together with the fan motor.
8. Remove the radiator fan motor and condenser fan motor from the radiator.

INSPECTION EC11A6700

1. Check for foreign material between the radiator fins.
2. Check the radiator fins for damage and straighten if necessary.
3. Check the radiator for corrosion, damage, rust or scale.
4. Check the radiator hoses for cracks, damage or deterioration.
5. Check the reservoir tank for damage.
6. Check the automatic transaxle oil cooler hoses for cracking, damage or deterioration (only A/T).

INSTALLATION ED1A6800

1. Fill the radiator and reservoir tank with clean coolant mixture.
2. Run the engine until the coolant has warmed up enough so that the thermostat valve is open. Then, stop the engine.
3. Remove the radiator cap and pour the coolant into the filler neck of the radiator. Fill the reservoir tank with the coolant to the upper level. Replace the radiator cap.
4. Check that there are no leaks from the radiator, hoses or connections.

RADIATOR FAN MOTOR

COMPONENTS ECHB6500

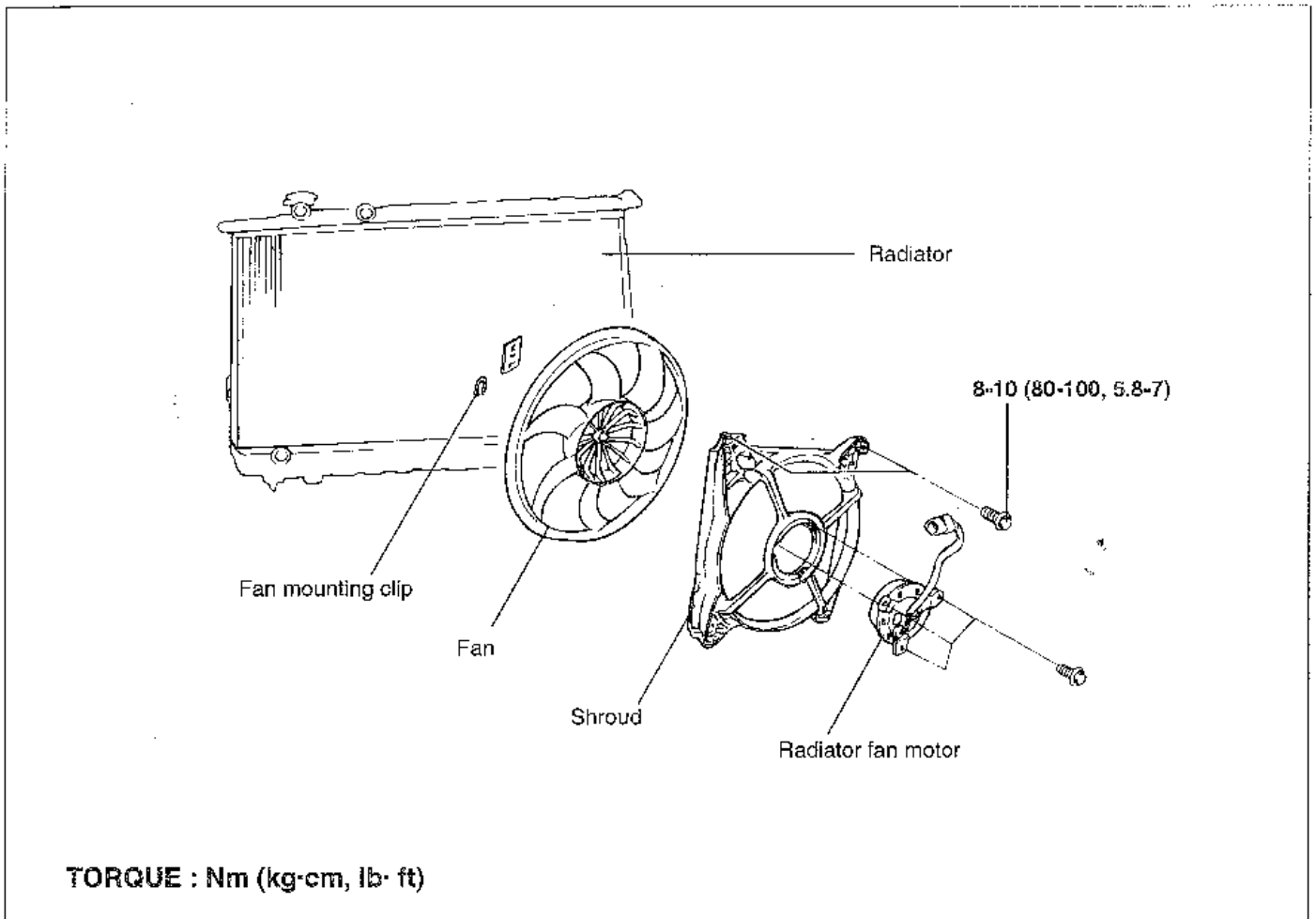

ECA9059A

REMOVAL ECJA6000

1. Disconnect the ground cable from the battery cable.
2. Disconnect the connectors from the fan motor and the harness from the shroud.
3. For vehicles with automatic transaxles, remove the oil cooler hose from the shroud.
4. Remove the four bolts holding the shroud.
5. Remove the shroud with the fan motor.
6. Remove the fan mounting clip and detach the fan from the fan motor.
7. Remove the three screws and detach the fan motor.

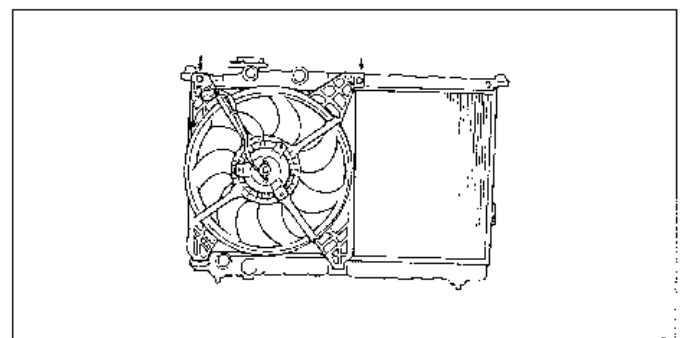

ECA9060A

INSPECTION

Radiator Fan Motor

1. Check that the radiator fan rotates when battery voltage is applied between the terminals (as shown in the table below).

2. Check that abnormal noise is not produced while the motor is turning.

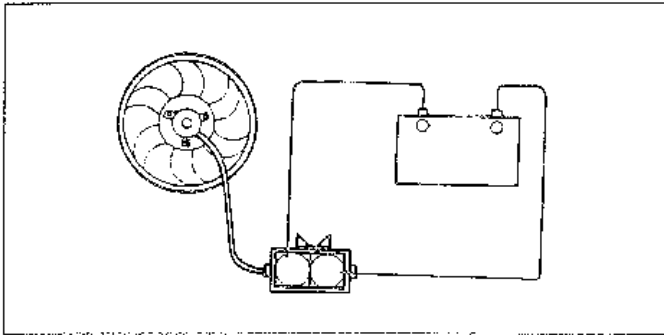

ECHA011C

RADIATOR FAN MOTOR RELAY

1. Remove the radiator fan motor relay (High and Low) from the relay box in the engine bay.

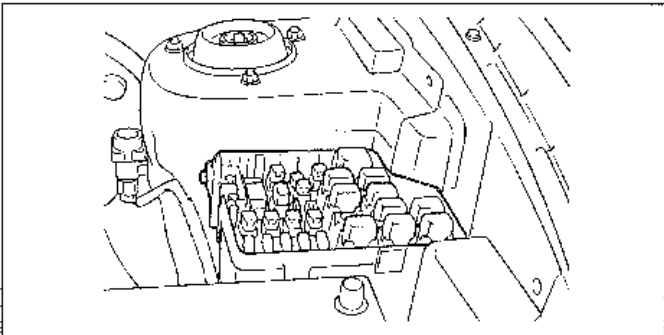

ECJA830A

2. Check the continuity of the terminals "2" and "4" with an ohmmeter.

Item	Terminal No.	Yes or No
ON	Terminal 1-3	Continuity
OFF	Terminal 1-3	Non continuity
	Terminal 2-4	Continuity

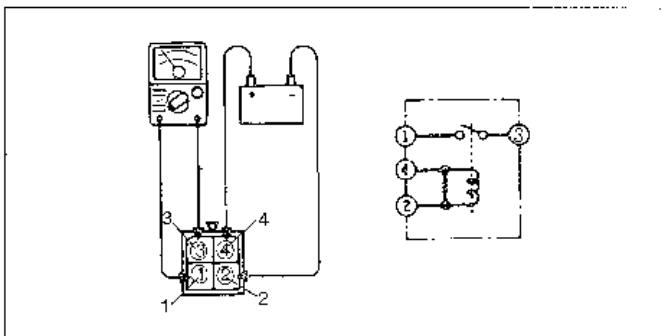

HFR250'6

INSPECTION ZCHB6700

RADIATOR FAN MOTOR

1. Check that the radiator fan rotates when battery voltage is applied between the terminals (as shown in the table below).
2. Check that abnormal noise is not produced while the motor is turning.

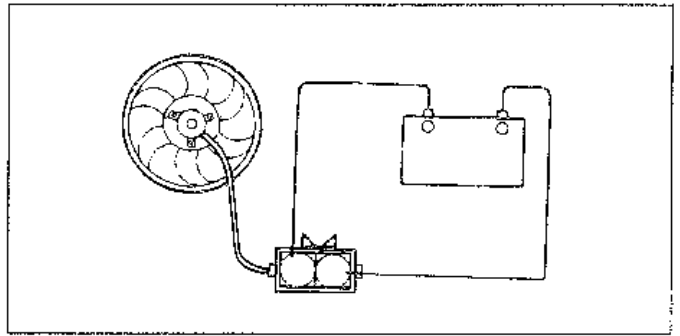

ECJA011C

RADIATOR FAN MOTOR RELAY

1. Remove the radiator fan motor relay (High and Low) from the relay box in the engine bay.

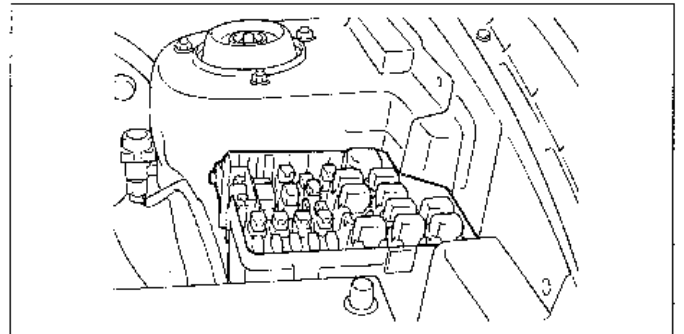

ECJA830A

2. Check the continuity of the terminals "2" and "4" with an ohmmeter.

Item	Terminal No.	Yes or No
ON	Terminal 1-3	Continuity
OFF	Terminal 1-3	Non continuity
	Terminal 2-4	Continuity

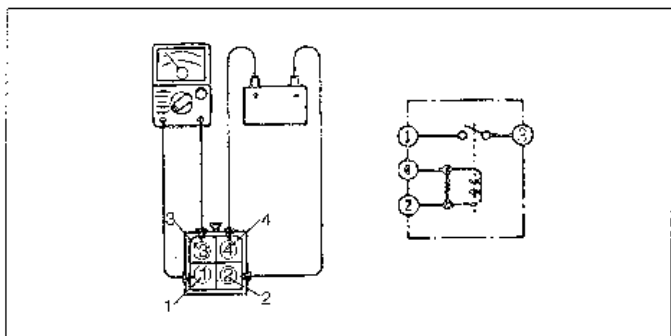

IJFR2E016

INSTALLATION

ECJA6100

Installation is in the reverse order of removal procedures.

NOTE

- Make sure the cooling fan does not come into contact with the shroud when installed.
- After installation, make sure there is no unusual noise or vibration when the fan is rotating.

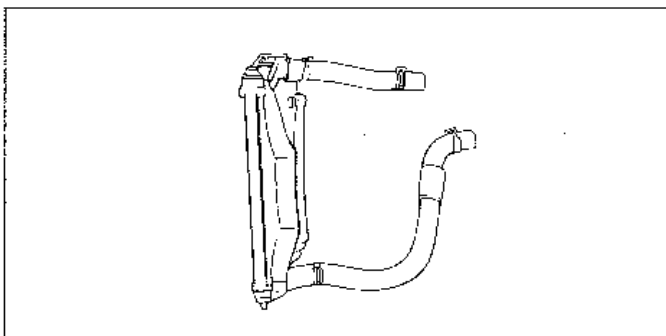

ECA90E1A

RADIATOR CAP

COMPONENTS EC-HB7000

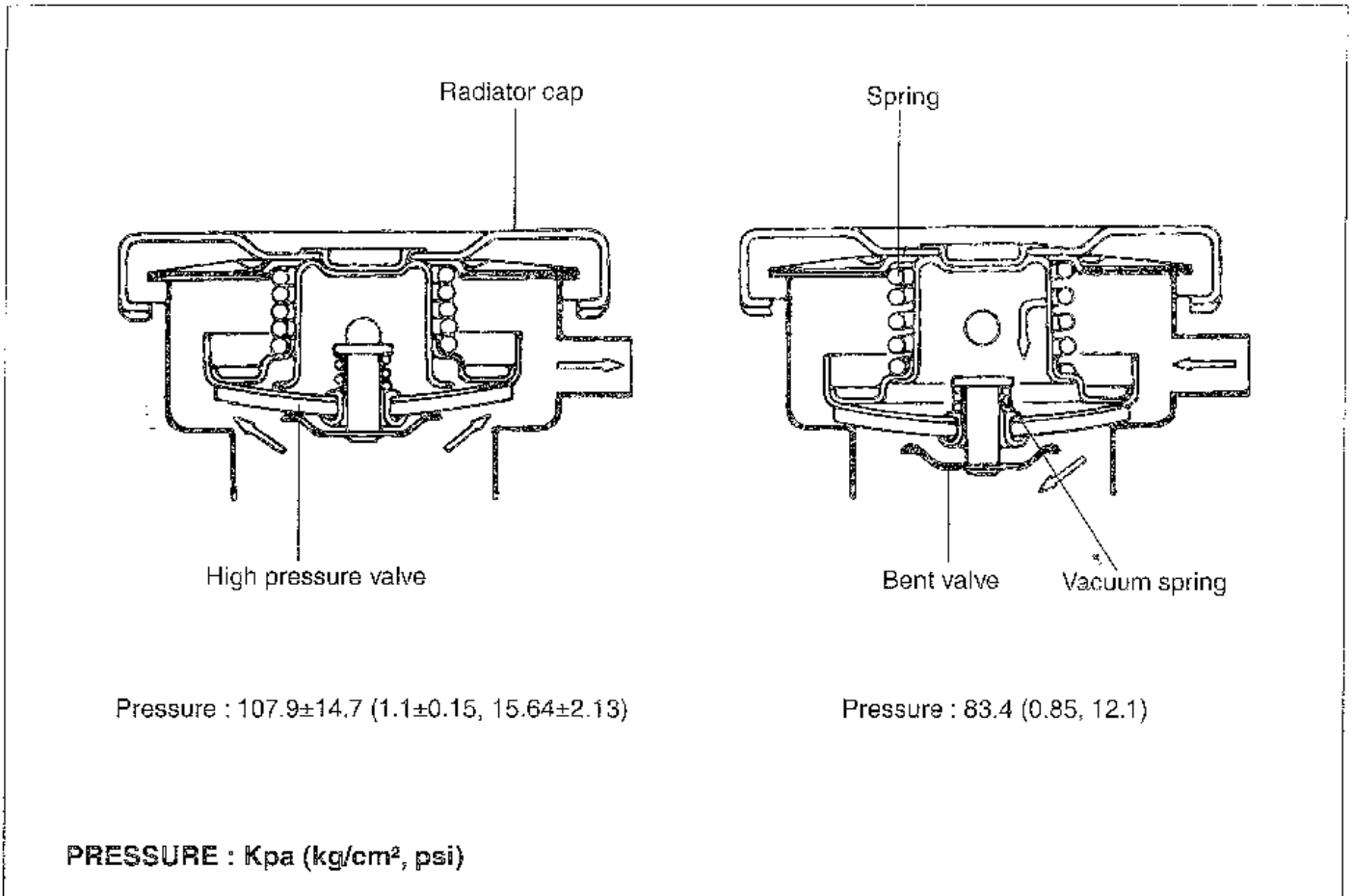

ECHA014A

INSPECTION EC-JAB300

1. Check the radiator cap for damage, cracks or weakening.

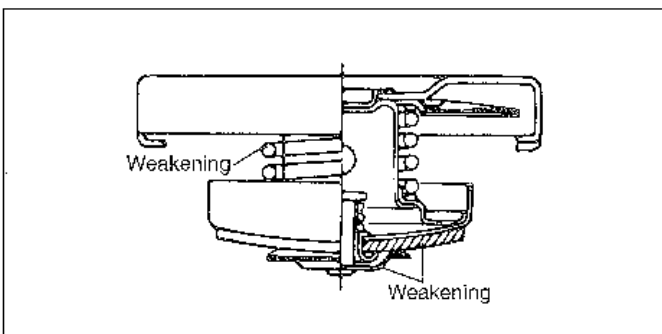

ECHA014B

4. Replace the radiator cap if the reading does not hold steady for about 10 seconds.

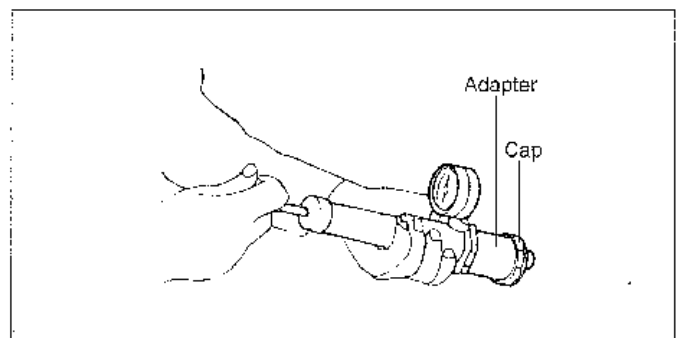

EC-HA014C

2. Connect the tester to the radiator cap.
3. Increase the pressure until the indicator stops moving.

THERMOSTAT

COMPONENTS ECH57200

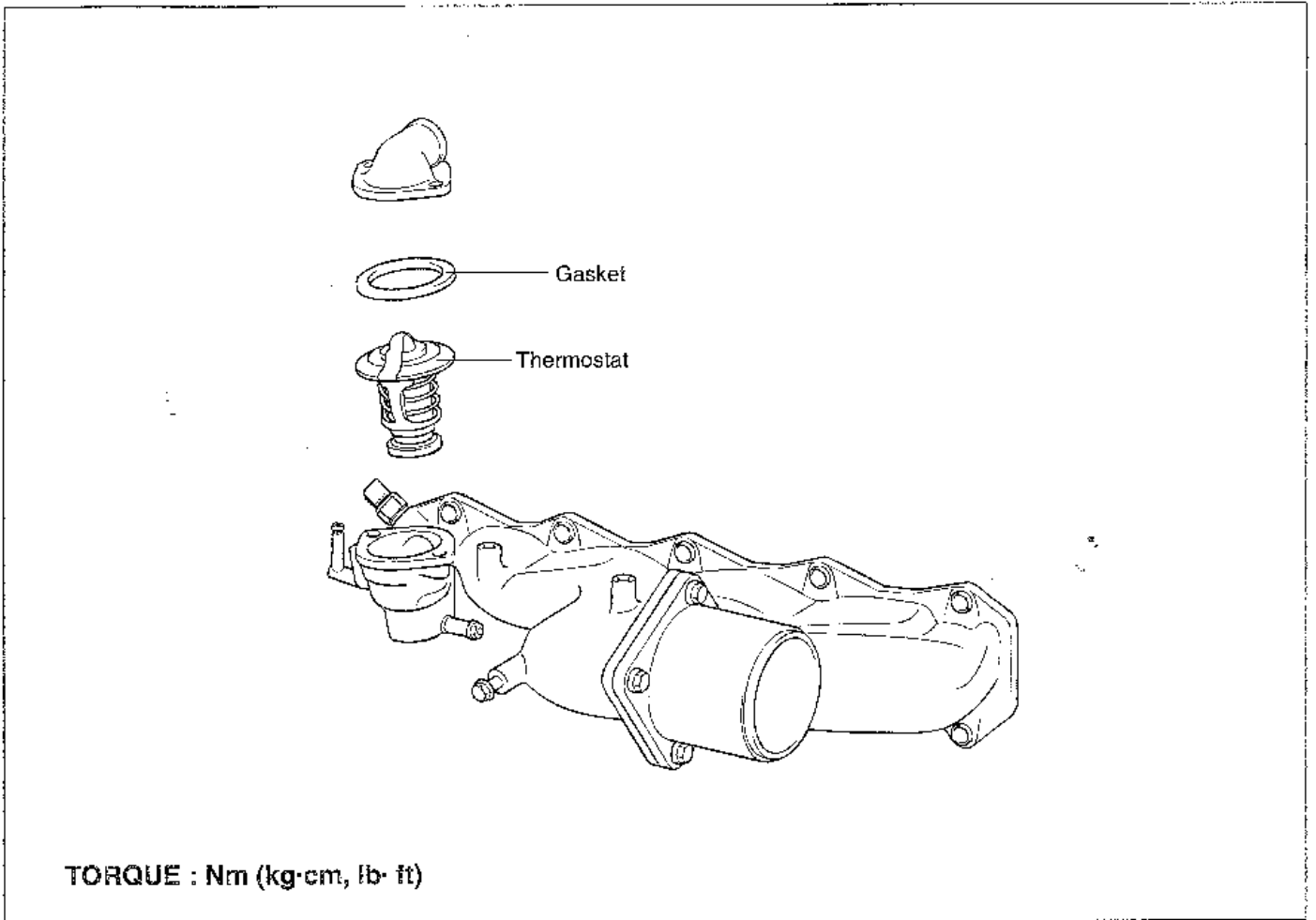

KCHB015A

REMOVAL ECH46700

1. Drain the coolant so its level is below the thermostat.
2. Remove the inlet fitting and gasket.
3. Remove the thermostat.

INSPECTION ECHA6800

1. Heat the thermostat as shown in the illustration.
2. Check that the valve operates properly.
3. Verify the temperature at which the valve begins to open.

Valve opening temperature :

80-84°C(176-183.2°F)

Full opening temperature : 95°C(203°F)

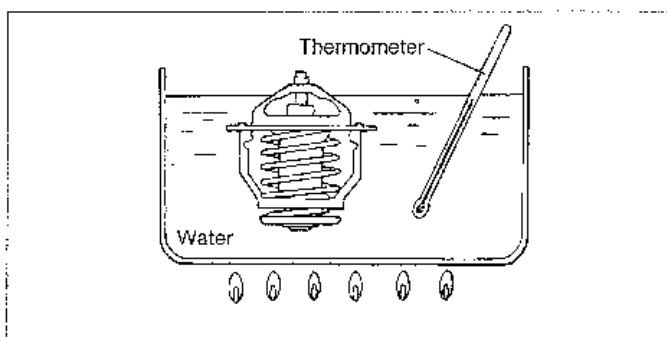

ECHA9600A

INSTALLATION ECHA6900

1. Check that the flange of the thermostat is correctly seated in the socket of the thermostat housing.
2. Install the inlet fitting.

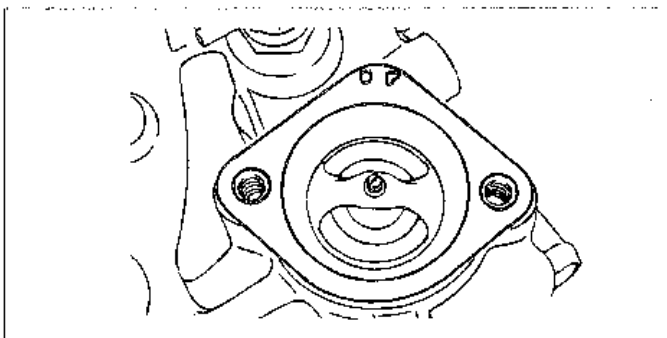

ECHA013B

Tightening torque

Engine coolant inlet fitting bolt :

10-15Nm(100-150kg.cm, 7-11lb.ft)

3. Refill the coolant.

LUBRICATION SYSTEM

ENGINE OIL

COMPONENTS ECP56500

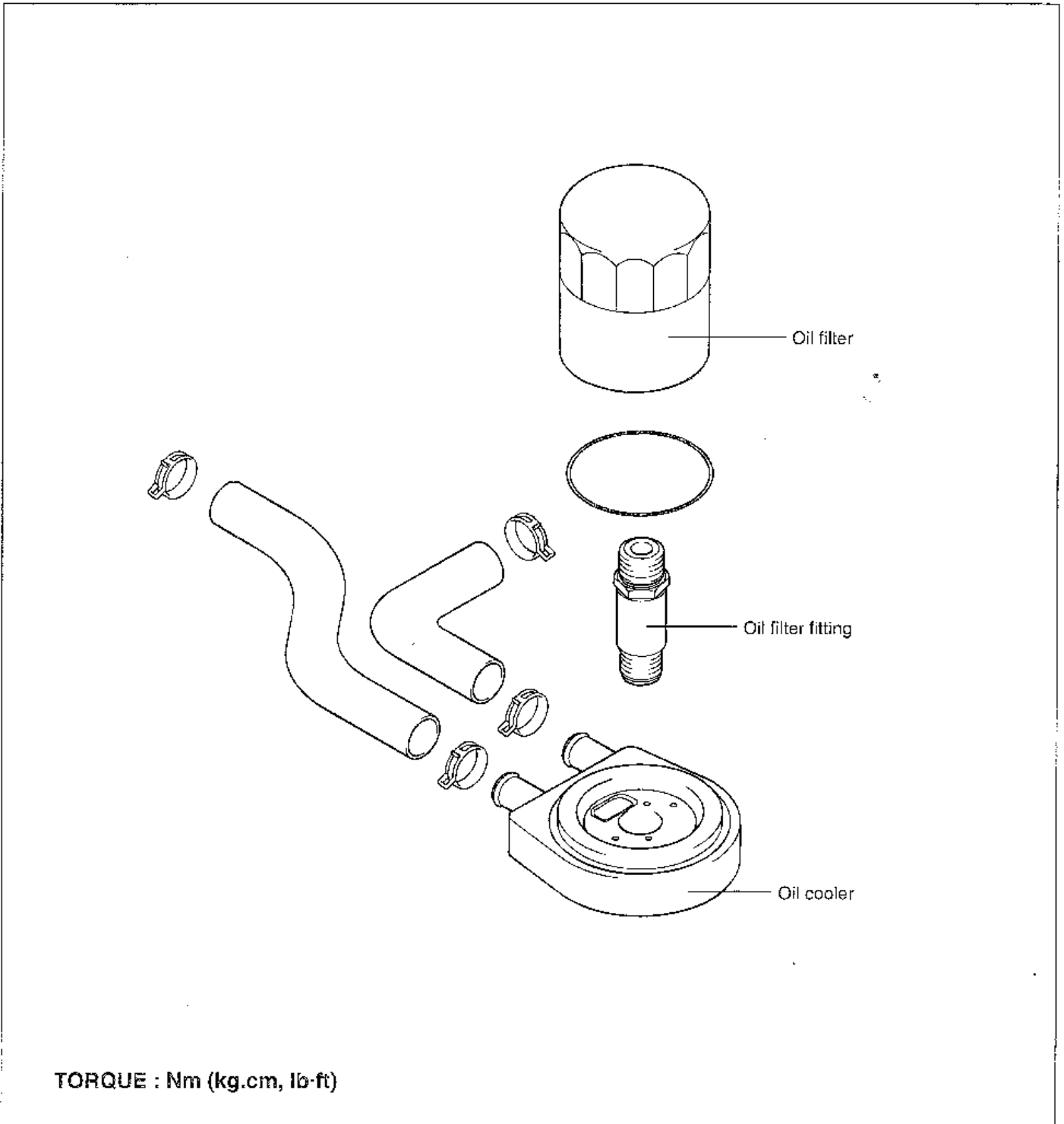

TORQUE : Nm (kg.cm, lb-ft)

REMOVAL ECH68510

1. Remove the oil filter.
2. Remove the coolant hose from the oil cooler.
3. Remove the oil filter fitting.
4. Remove the oil cooler from the oil pump.

INSPECTION ECH68520

1. Check for oil leaks.
2. Check the oil cooler for damage.

OIL PUMP

COMPONENTS ECHB800C

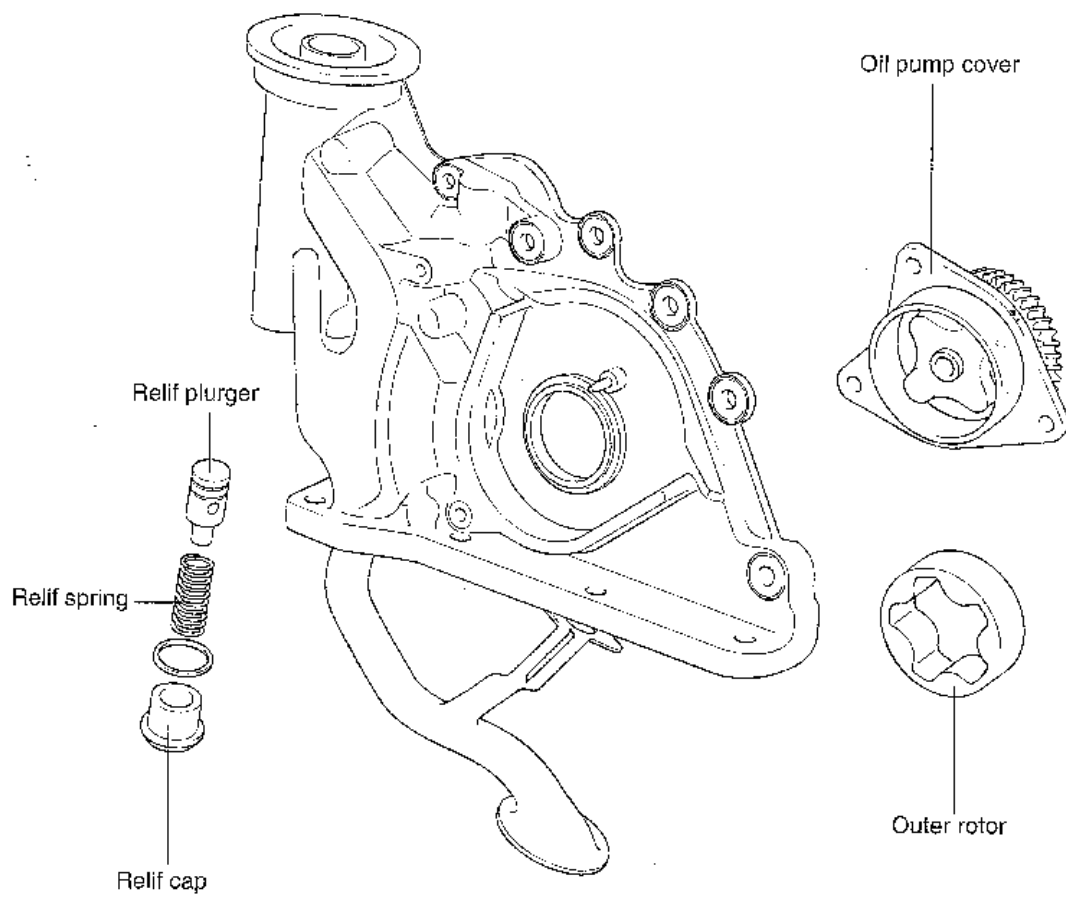

TORQUE : Nm (kg.cm, lb-ft)

DISASSEMBLY ECHB9100

OIL PUMP

Before removing the oil pump outer and inner gears, mark the outer gear to make sure that it goes back to the position with correct direction.

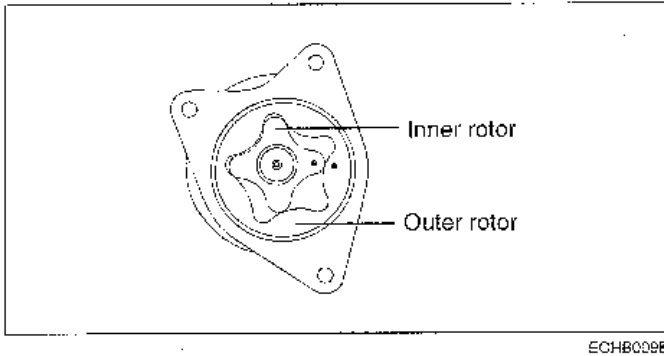

ECHB009B

INSPECTION ECHB9200

OIL PUMP

1. Install the outer and inner gear into the front case and make sure that they turn smoothly with no excessive play between them.
2. Check the side clearance (drive gear and drivengear))

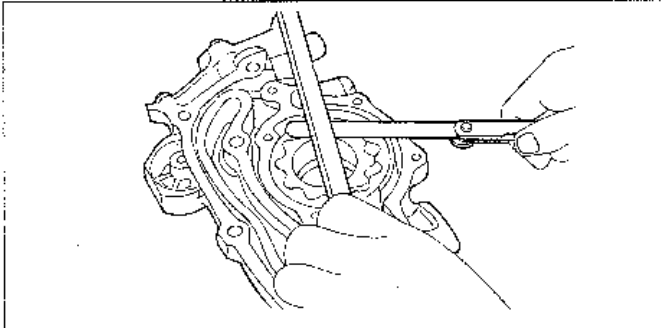

EDA9340B

Standard : 0.02 - 0.07 mm (0.00078 - 0.0027 in.)

3. Check the tip clearance.

[Standard]

Drive gear : 0.12 - 0.2 mm (0.00472 - 0.0078 in.)

Driven gear : 0.13 - 0.23 mm (0.0051 - 0.009 in.)

INSTALLATION ECHB9300

OIL PUMP

Install the outer gear, ensuring it is in position with correct direction according to the alignment mark made during disassembly.

NOTE

When installing the gears, be sure to apply engine oil to the entire surfaces of the gears.

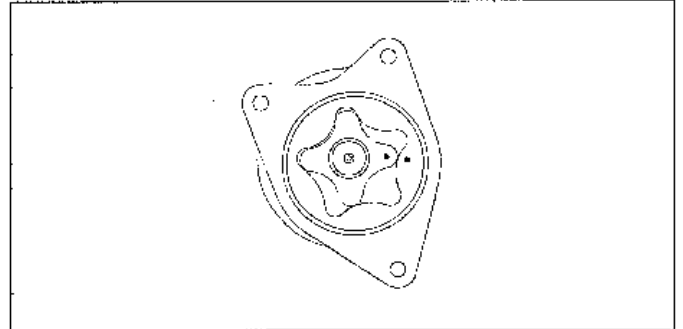

KCHB009B

REMOVAL ECHB7700**OIL PRESSURE SWITCH**

To remove the oil pressure switch, use Oil Pressure Switch Wrench.

INSPECTION ECHB7800**OIL FILTER BRACKET**

1. The oil filter mounting surface must be free from damage.
2. Check for cracks and oil leaks.
3. Make sure that the relief plunger slides smoothly and the relief spring is not damaged.

OIL PRESSURE SWITCH

1. Connect a tester (ohm range) between the terminal and the body of the switch to check for continuity. The switch is normal if there is continuity. If there is no continuity, replace the switch.

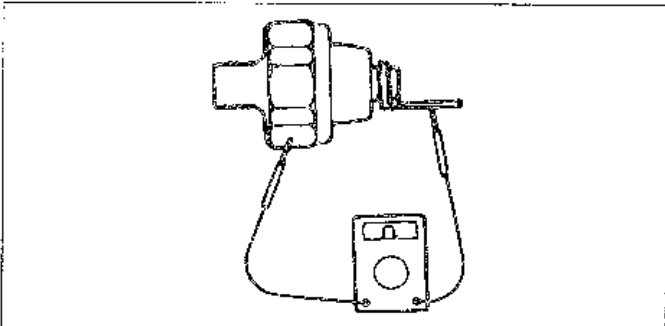

ECLA0130

2. Insert a thin rod in the oil hole of the switch and push it in lightly. The switch is normal if no continuity is detected (infinite resistance on the tester). If there is continuity, replace the switch.

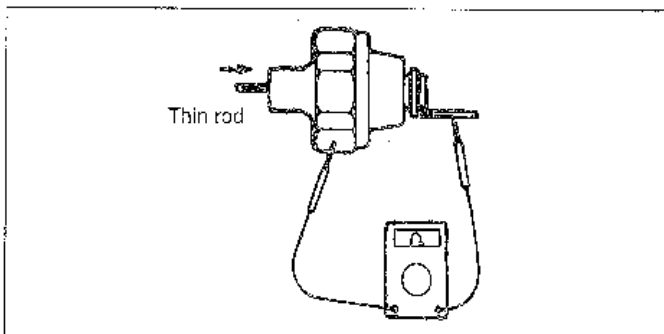

ECLA0150

3. Apply a 0.5 kg/cm² pressure to the oil hole. The switch is normal if there is no continuity. Also check for air leaks. If any air leaks are detected, the cause may be a broken diaphragm. Replace the switch if it leaks.

OIL JET, CHECK VALVE

1. Check the oil jet and check valve for clogging.
2. Check the oil jet for damage and deformation.

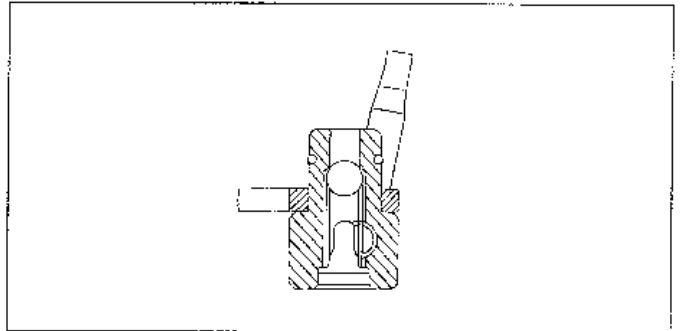

KCH3008D

INSTALLATION ECHB7300**OIL PRESSURE SWITCH**

Before installation, apply sealant to the switch threads.

NOTE

The sealant must not get into the thread top surface. Use care not to torque excessively.

INTAKE AND EXHAUST SYSTEM

EXHAUST PIPE

COMPONENTS ECH88600

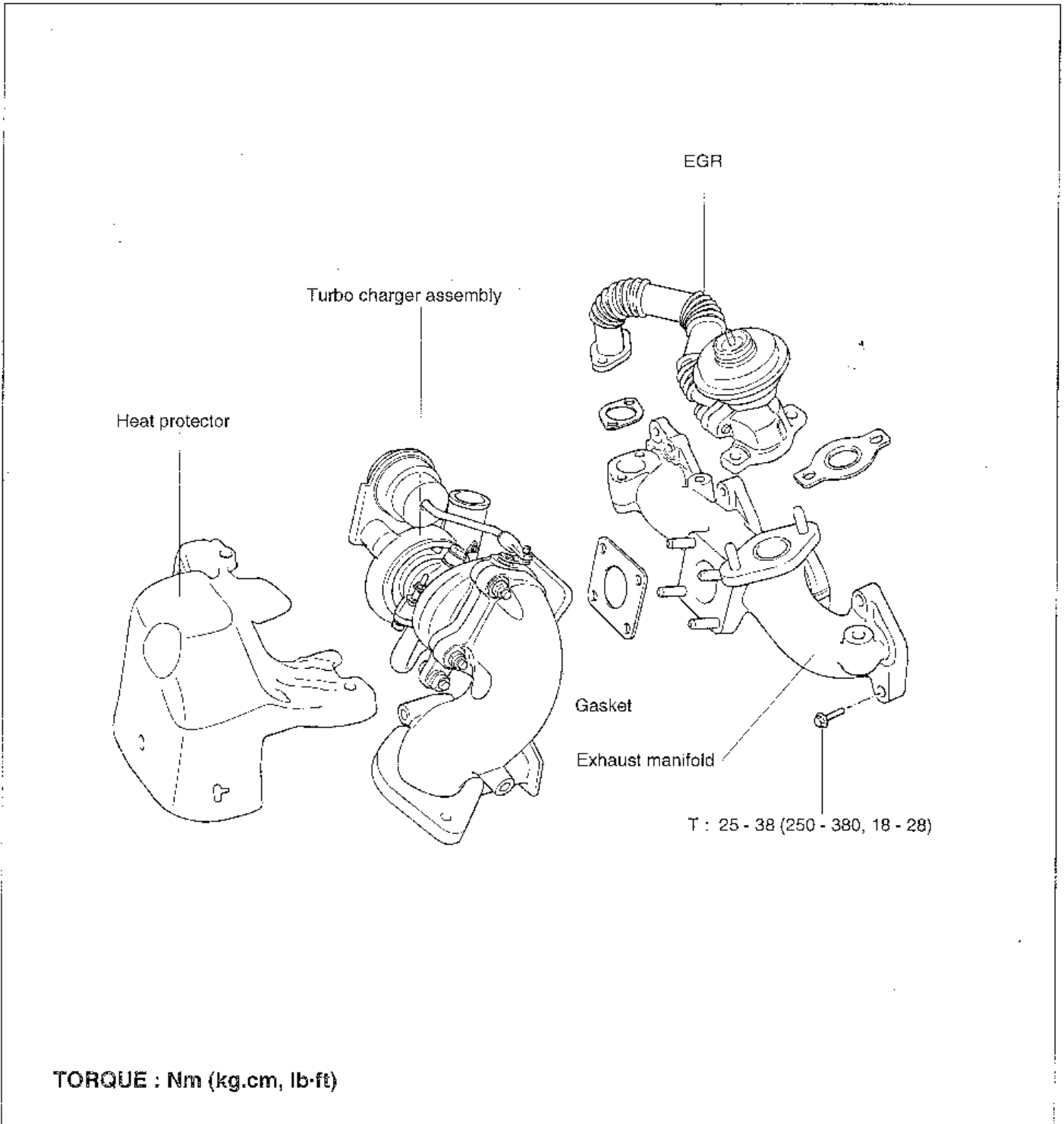

TORQUE : Nm (kg.cm, lb-ft)

MUFFLER

COMPONENTS ECH38700

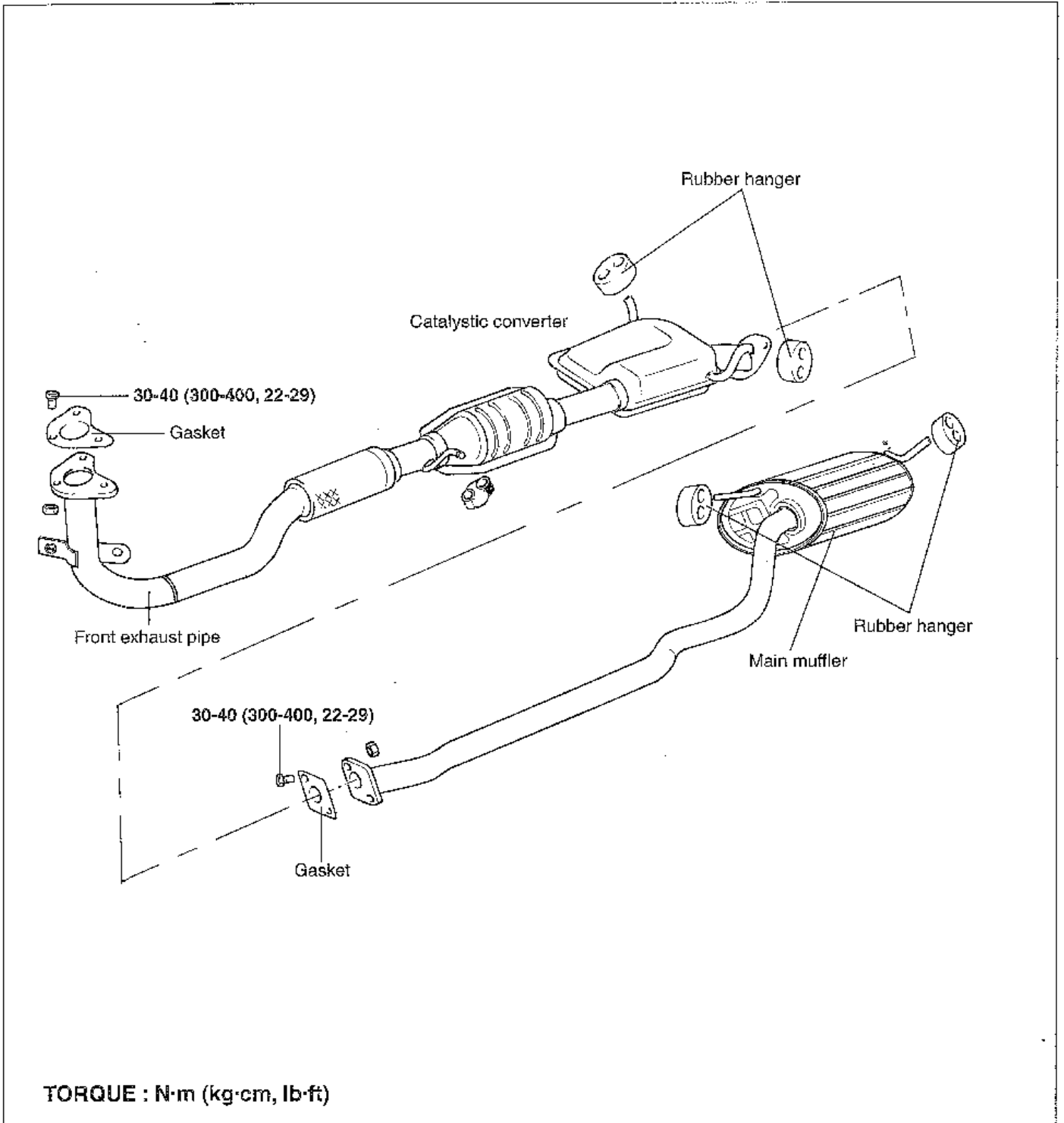

REMOVAL ECJA810D

MAIN MUFFLER

⚠ CAUTION

Before removing or inspecting the exhaust system, ensure that the exhaust system is cool.

1. Disconnect the main muffler from the center exhaust pipe.

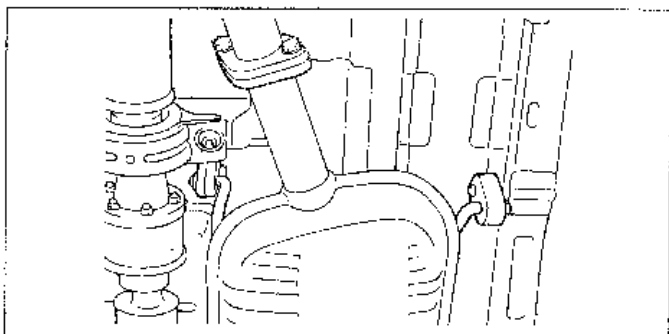

ECJA810A

2. Remove the rubber hangers and remove the main muffler.

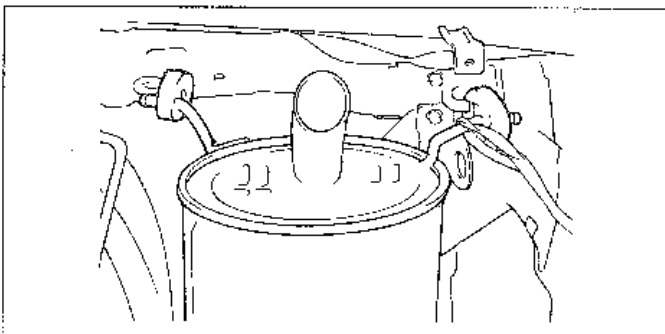

ECJA810B

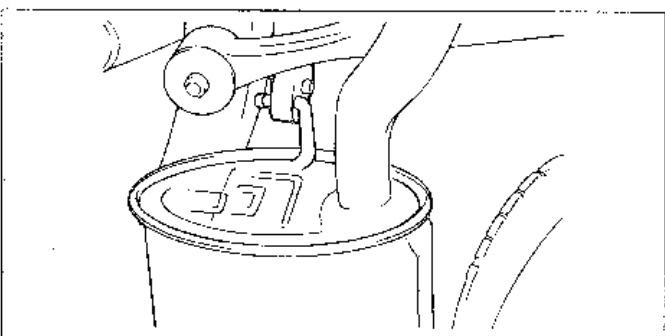

ECJA810C

FRONT EXHAUST PIPE (INCLUDING CATALYTIC CONVERTER)

1. Remove the front exhaust pipe from the center exhaust pipe.
2. Remove the front exhaust pipe bolts and exhaust manifold pipe mounting nuts.

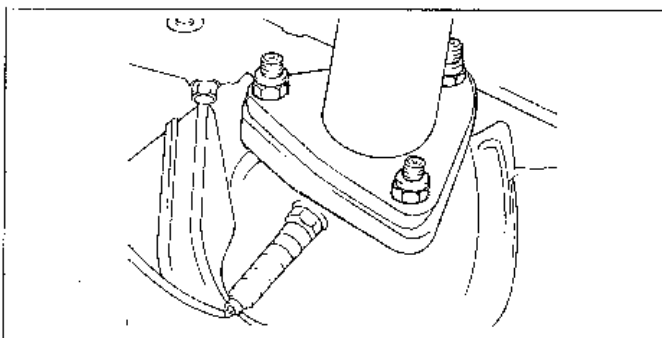

ECJA250B

3. Remove the front exhaust pipe from the rubber hanger.

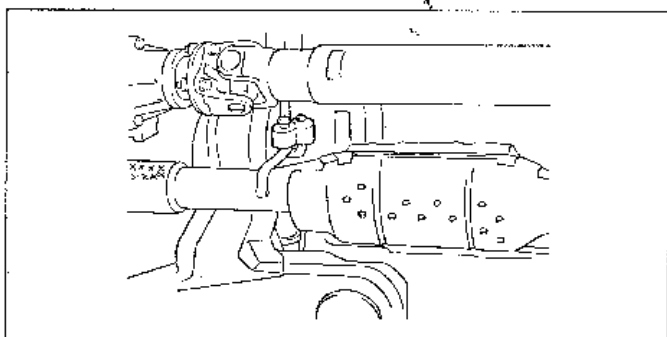

EDJA810C

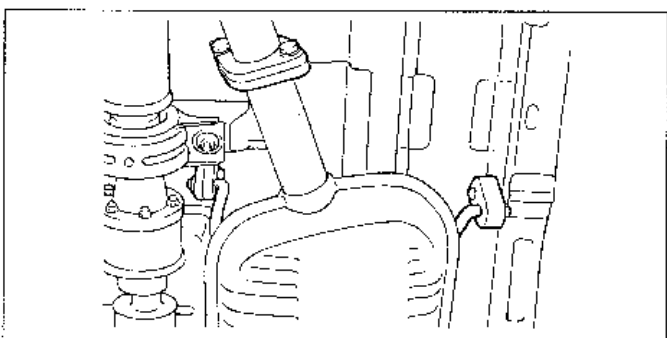

ECJA810A

INSPECTION ECHA8200

1. Check the mufflers and pipes for leaks, corrosion and damage.
2. Check the rubber hangers for deterioration and cracks.

INSTALLATION ECJA8300

1. Temporarily install the front exhaust pipe (catalytic converter assembly), the center exhaust pipe and the main muffler in this order.
2. Install the rubber hangers so that they hang equally (left and right).
3. Tighten the parts securely and then confirm that there is no interference with any of components.

COMPONENTS ECH8740

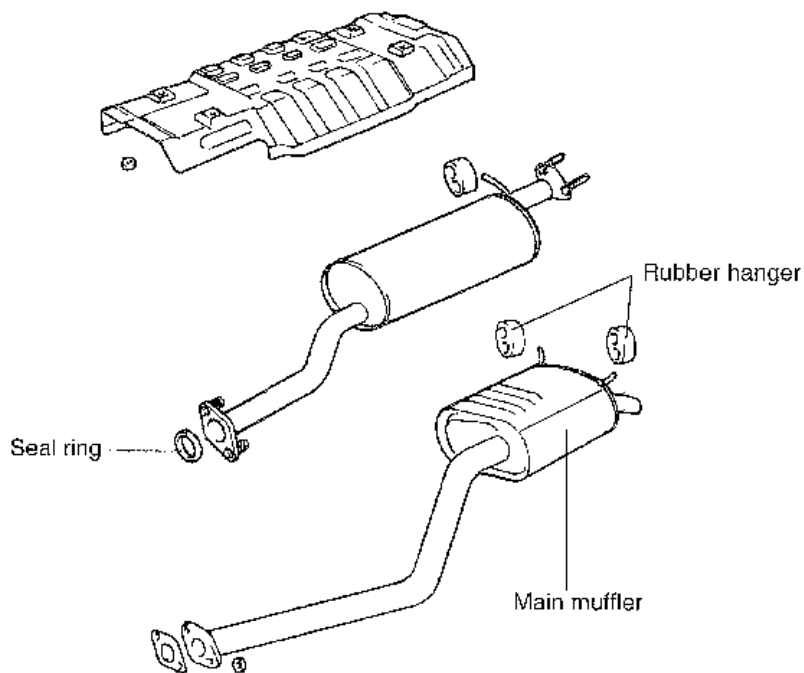
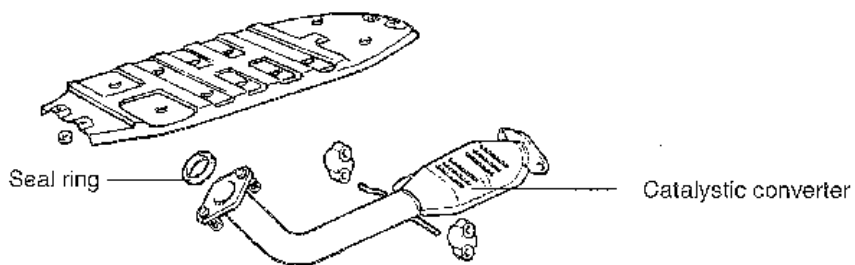

TORQUE : Nm (kg.cm, lb-ft)

REMOVAL ECHB8750**MAIN MUFFLER****⚠ CAUTION**

Before removing or inspecting the exhaust system, ensure that the exhaust system is cool enough.

1. Disconnect the main muffler from the center exhaust pipe.

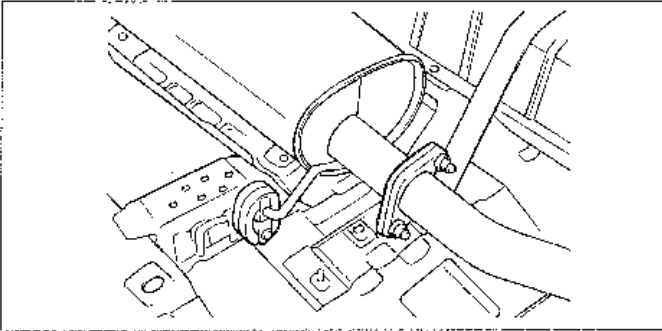

ECHA019E

2. Remove the rubber hangers and take out the main muffler.

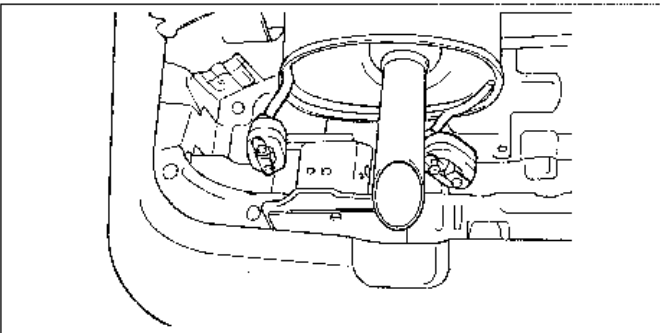

ECHA019B

CENTER EXHAUST PIPE

1. Disconnect the center exhaust pipe from the main muffler.
2. Remove the center exhaust pipe from the front exhaust pipe.

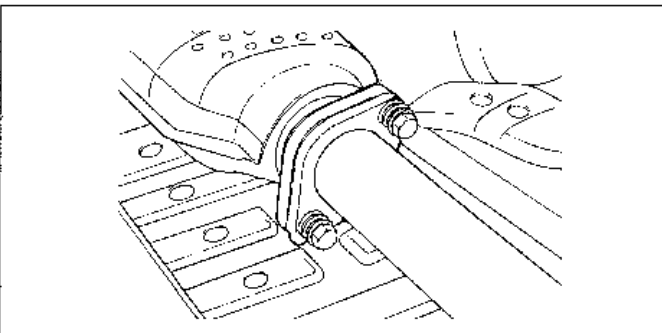

KCH3500C

3. Remove the rubber hangers and take out the center exhaust pipe.

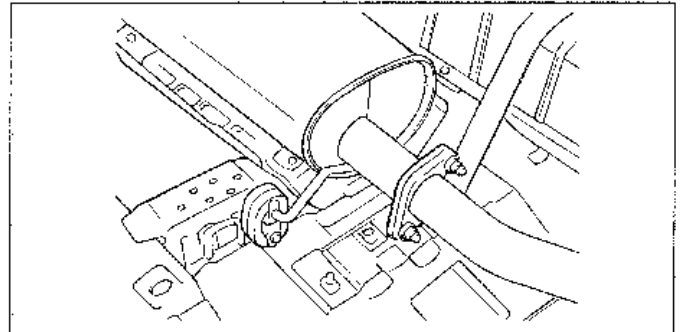

ECHA019E

FRONT EXHAUST PIPE (INCLUDING CATALYTIC CONVERTER)

1. Remove the front exhaust pipe from the center exhaust pipe.
2. Remove the front exhaust pipe bolts and exhaust manifold pipe mounting nuts.
3. Remove the front exhaust pipe from the rubber hanger.

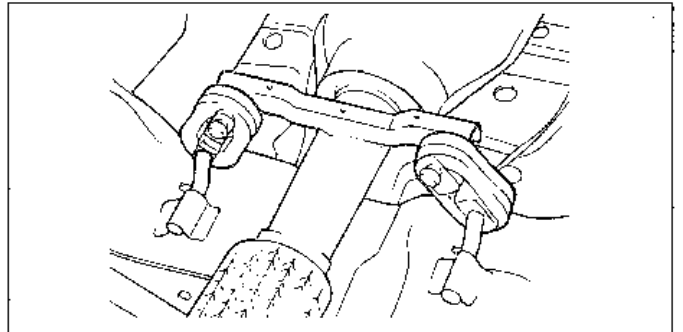

ECHA019H

INSTALLATION ECH88770

1. Temporarily, install the front exhaust pipe (catalytic converter assembly), the center exhaust pipe and the main muffler in this order.

Assembly procedure

- 1) Insert seal ring into exhaust manifold flange.
- 2) Insert spring into bolt.
- 3) Tighten left side lightly after tightening right side lightly.
- 4) Tighten left side after tightening right side according to the torque indicated.
- 5) The distance (8.5 mm : Between flanges) must be checked.

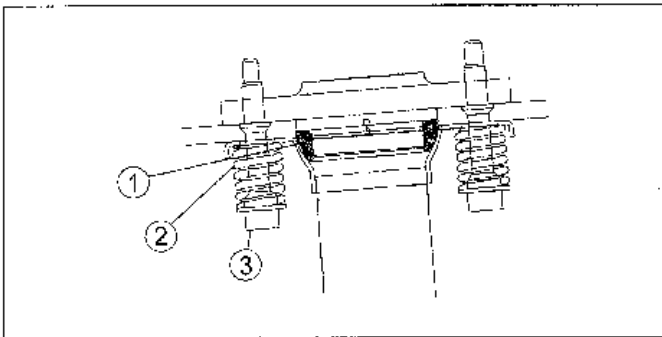

KCH850-B

NOTE

Whenever installing the seal ring, always replace a new one.

2. Install the rubber hangers so that they can be identical (left and right) in length.
3. Tighten the parts securely and then confirm that there is no interference with any of components.

TURBO CHARGER (TC)

COMPONENTS ELC80650

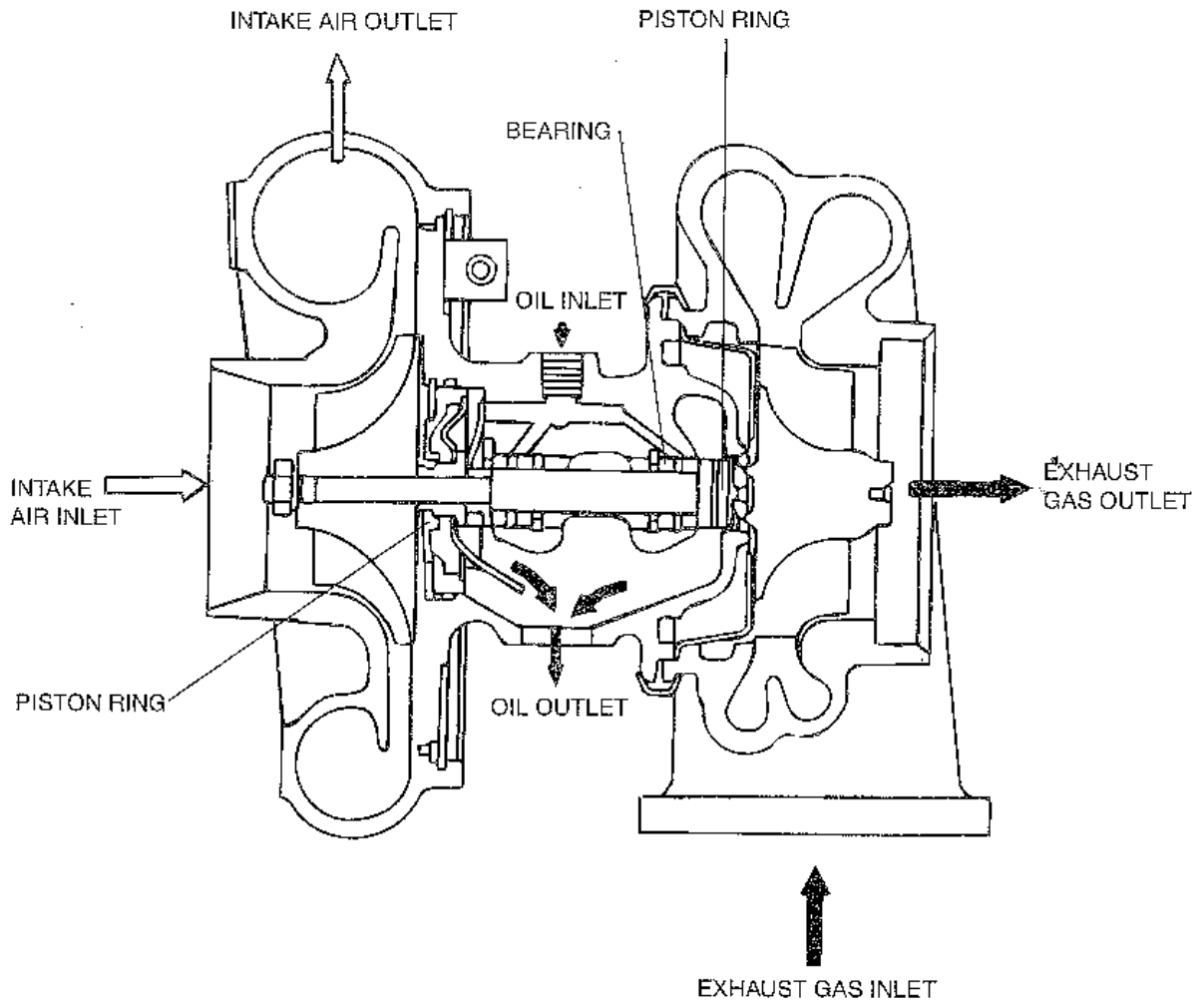

TORQUE : Nm (kg.cm,lb.ft)

COMPONENTS ELCB0660

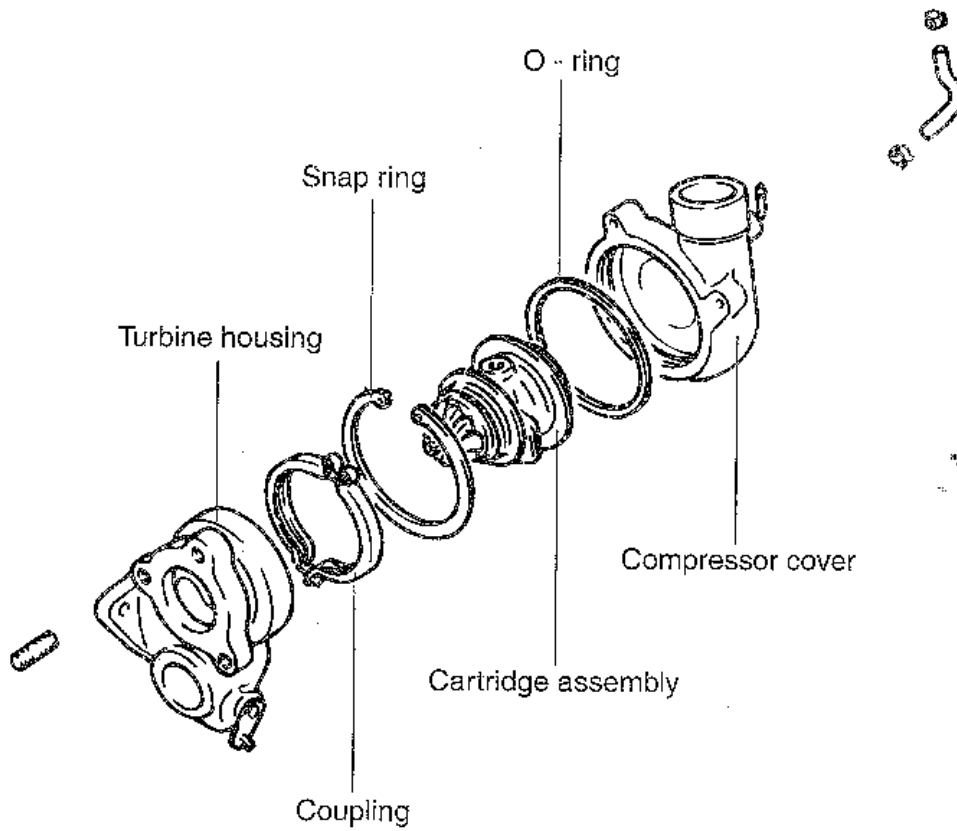

* Replace the gasket with new ones after removal.

TORQUE : Nm (kg.cm,lb.ft)

ECLA016A

DISASSEMBLY ECH-B3820

1. Before removal, make the matching mark on compressor cover bearing housing and turbine housing.

CAUTION

Be sure not to damage the compressor and turbine wheel blade.

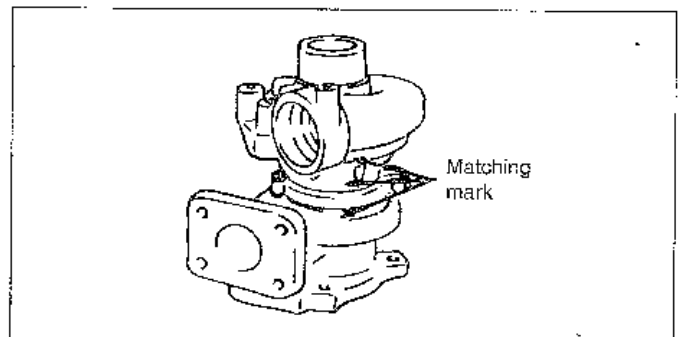

ECLA016B

- Loosen the assembly and tap the housing by plastic hammer when removing the housing.

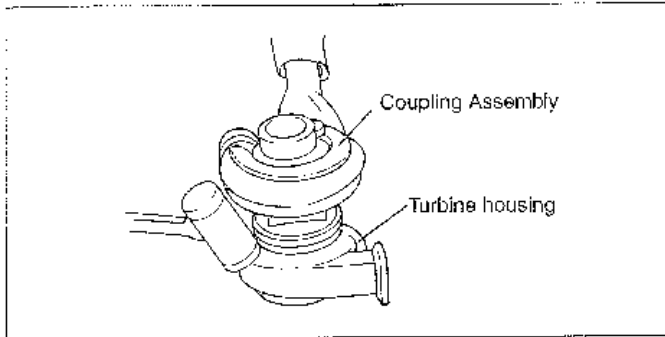

- Remove the snap ring using snap ring filler.

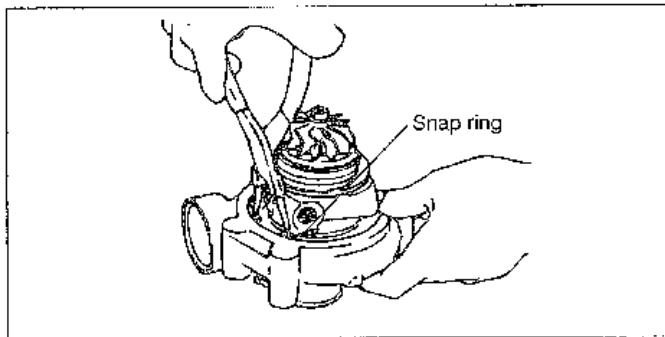

- Remove by tapping the compressor cover of cartridge assembly with plastic hammer.

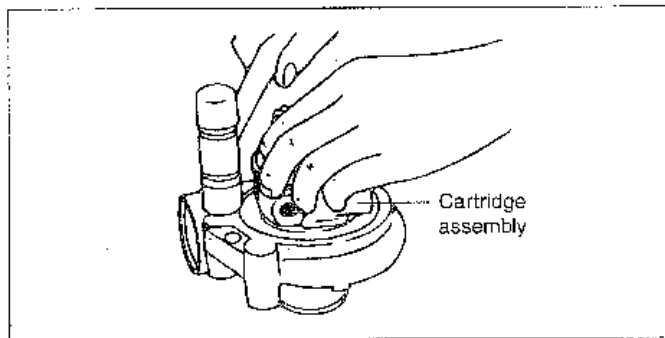

CLEANING

- Use a heavy duty carbon solvent to loosen the carbon from the parts.

⚠ CAUTION

Do not use caustic solutions, wire brushes, or wire wheels to remove carbon deposits from any turbo charger part.

- A small, closed, agitated cleaning tank and solvent will give the best results.

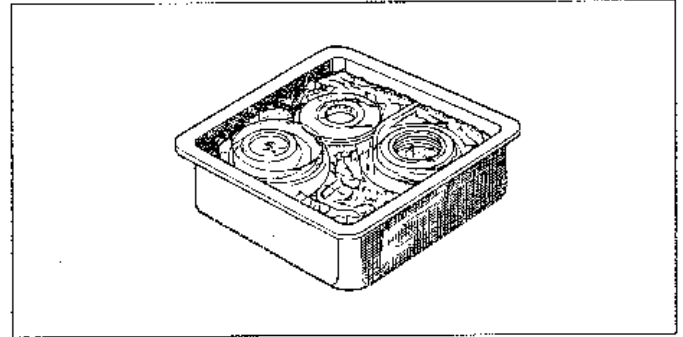

- After the carbon is loosened, use a hard, bristle type brush and remove all dirt particles.

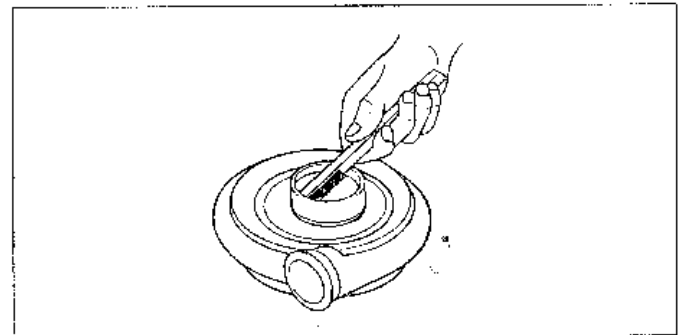

- Clean all drilled passages with air under pressure and put oil on cleaned parts to prevent corrosion.

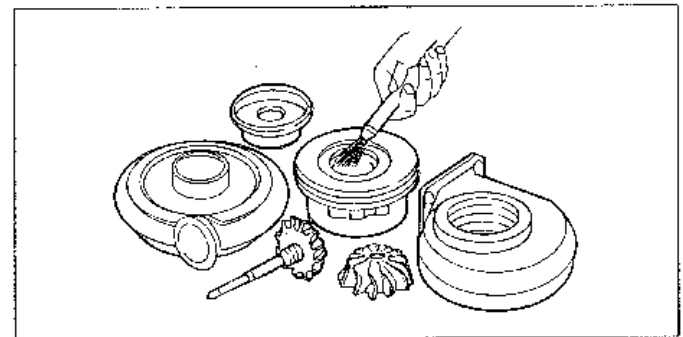

INSPECTION

- Check the inner housing contacting turbine wheel for crack, pitching and other damages caused by over-heat.
- Make sure that the waste gate valve lever operates freely by hands.
- Make sure there are no damages on the inner housing surface contacting compressor wheel.

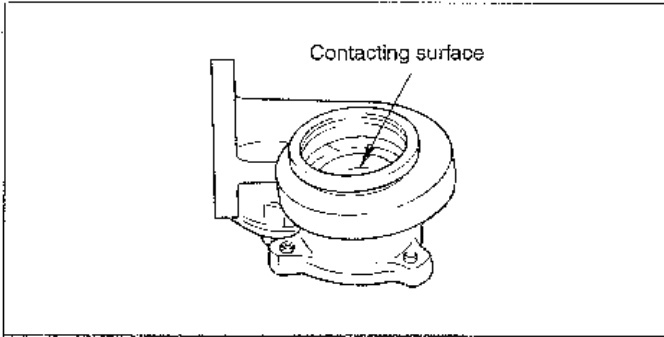

ECLA016E

4. Turbine wheel and shaft assemblies with cracks in the blades or broken blades can not be used again. If the blades are slightly bent, it can be used again but severely bent blades can not be reused.

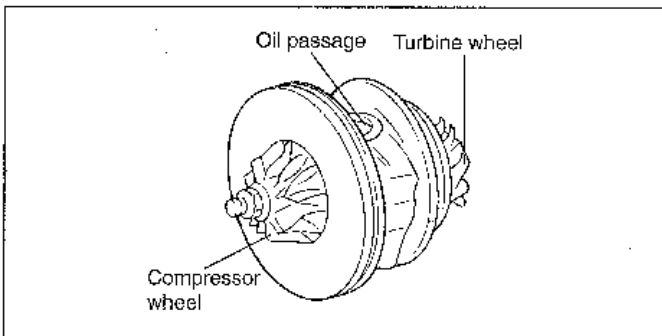

ECLA016F

5. Check if there are foreign materials disturbing the oil flow in the oil passage of cartridge assembly.

WASTE GATE INSPECTION

1. Check the waste gate rod operation under the pressure below.

Nominal Value : 77.5 kPa (0.79 kgf / cm²)

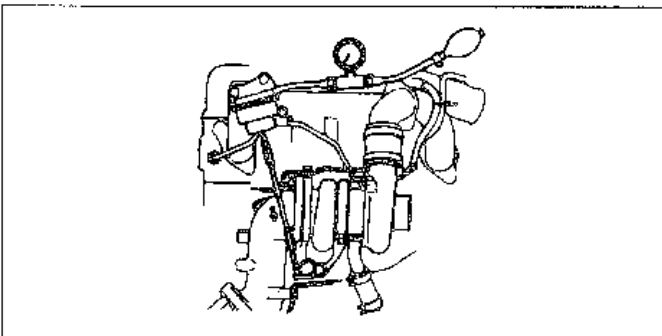

EC_A016J

REASSEMBLY ELC30030

1. Apply engine oil to new O-ring and insert the O-ring to the groove of cartridge assembly.

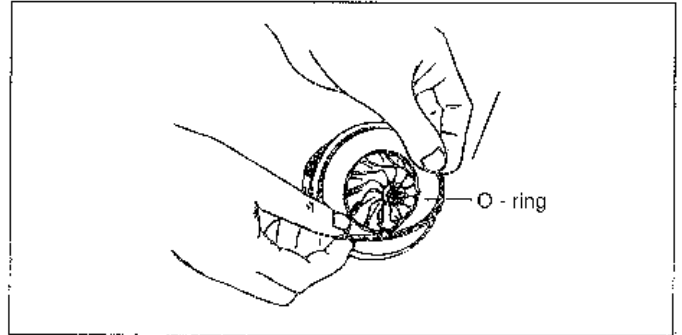

ECLA016G

2. Assemble cartridge assembly and compressor cover matching the mark.

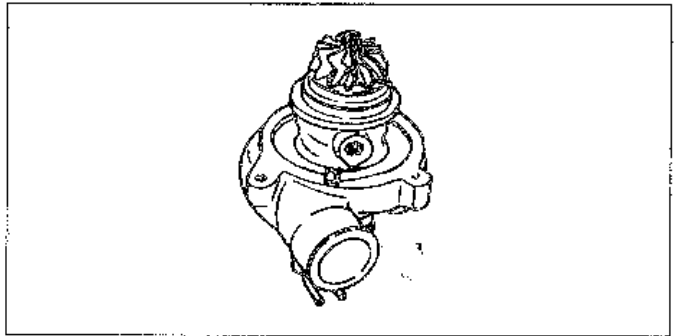

ECLA016H

3. Install the snap ring as shown in the figure.

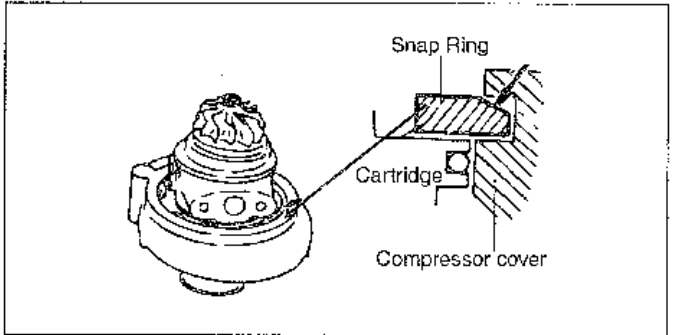

ECLA016I

4. Before reassembly, make sure that the turbine housing matching mark is matched with compressor cover and cartridge assembly.

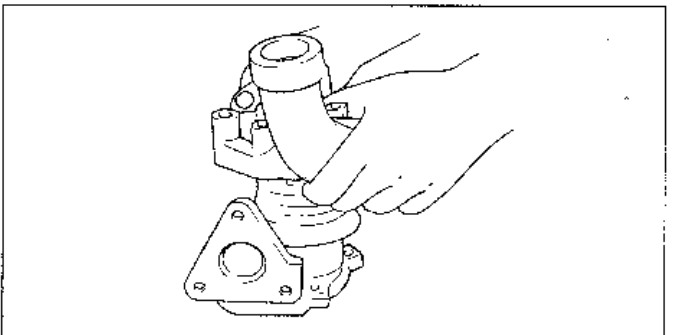

H75'010D

INTERCOOLER

COMPONENTS ECHB3840

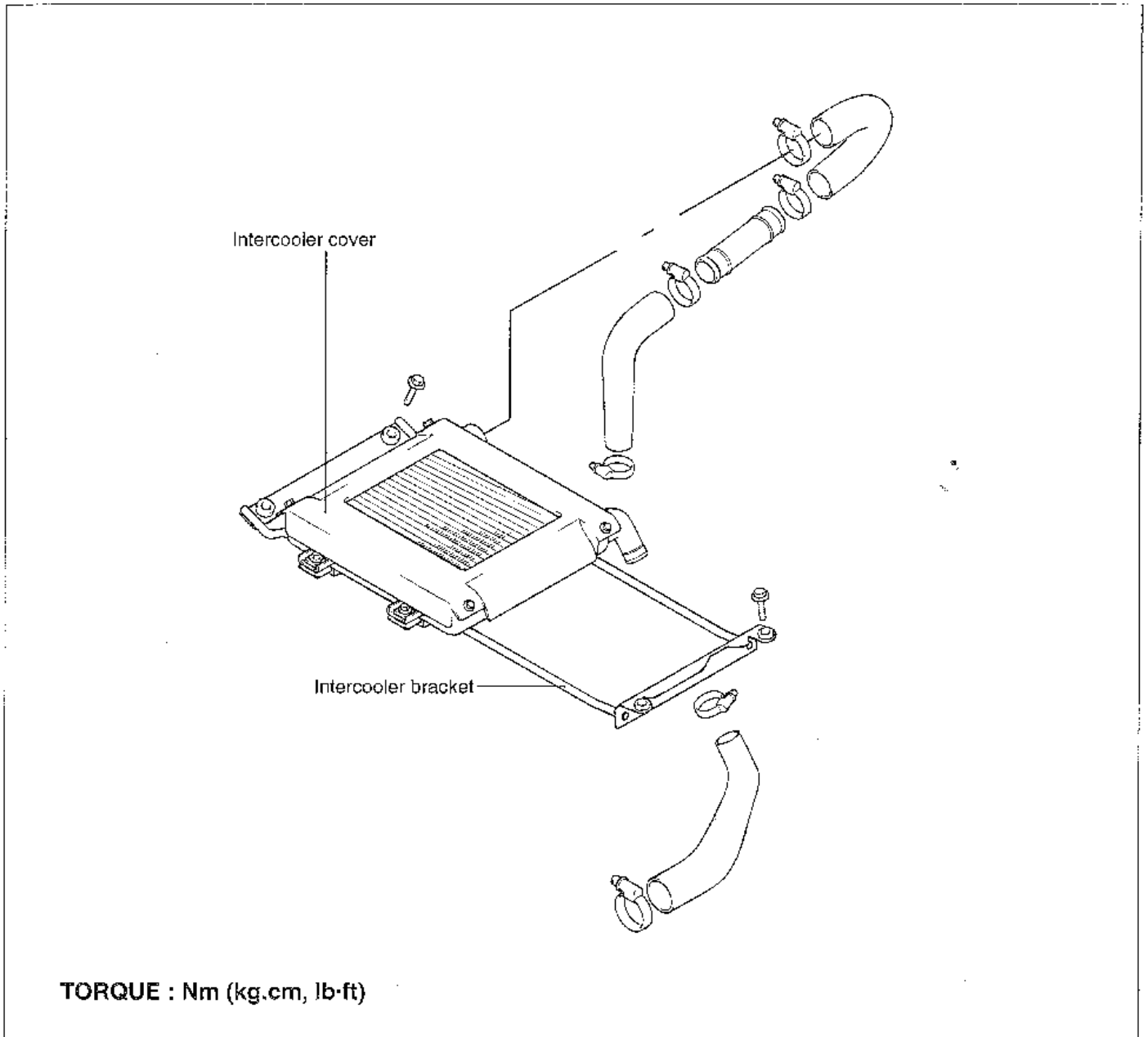

KCHB011A

REMOVAL ECHB6850

1. Remove the intercooler cover.
2. Disconnect the fan motor and air temperature switch connector.
3. Remove the air hoses:
4. Remove the intercooler assembly.
5. Remove the fan motor assembly.
6. Remove the intercooler bracket.

COMPONENTS ECH58860

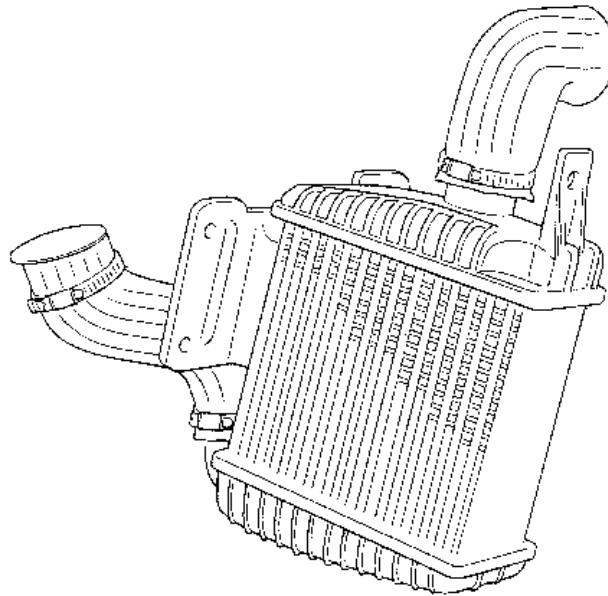

TORQUE : Nm (kg-cm, lb- ft)

KCHB011B

REMOVAL ECH58870

1. Remove the front tire (Driver side).
2. Remove the inner fender protector (Driver side).
3. Remove the battery.
4. Remove the air hoses.
5. Remove the intercooler assembly.

AIR CLEANER (ACL)

COMPONENTS EC-B3900

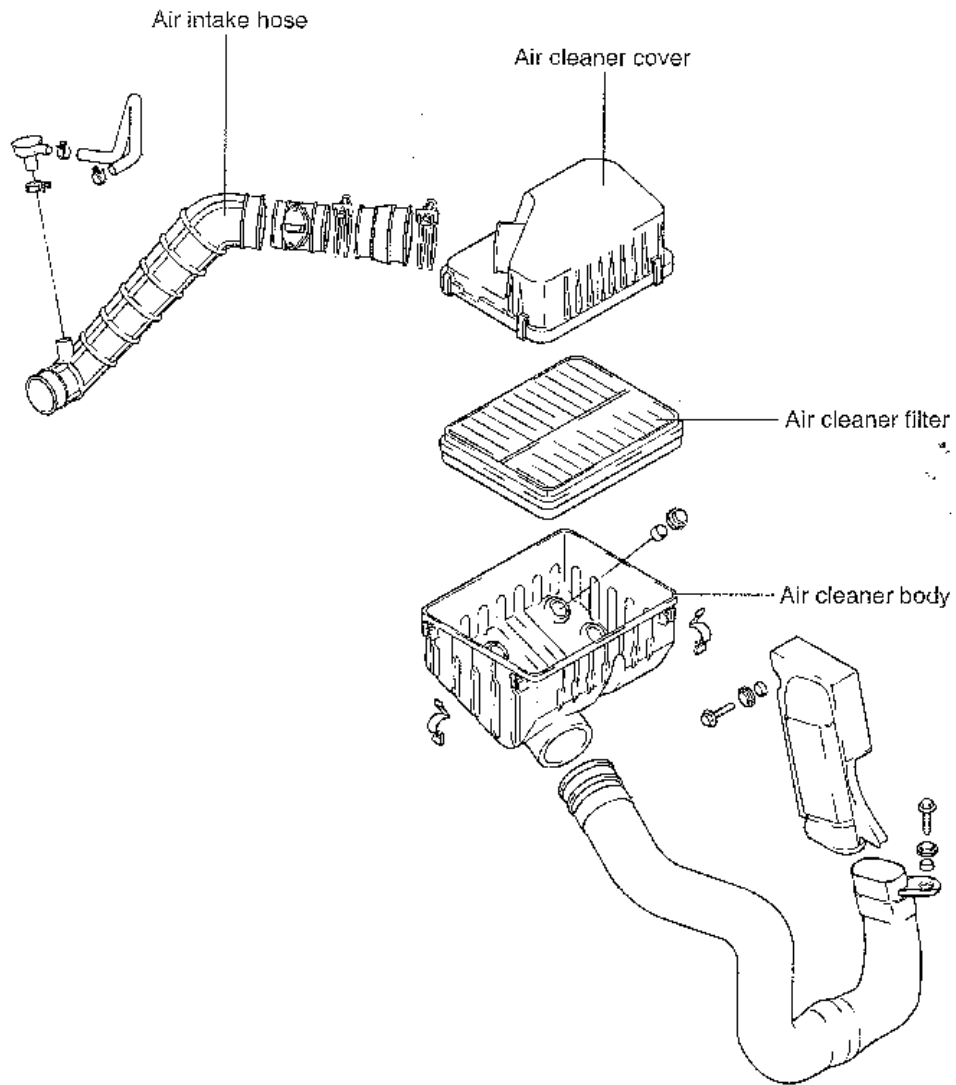

TORQUE : Nm (kg.cm, lb.ft)

REMOVAL ECHB691G

1. Disconnect the air flow sensor connector.
2. Remove the air intake hose at the air cleaner.
3. Remove the three bolts attaching the air cleaner mounting brackets.
4. Detach the air cleaner.

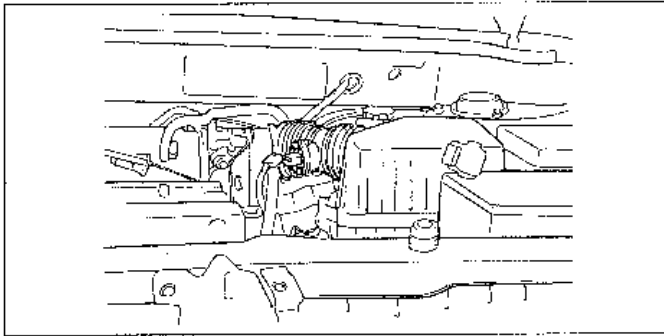

ECJA670B

5. Remove the air flow sensor from the air intake hose.

CAUTION

Do not pull on the air flow sensor wires.

INSPECTION ECJA870G

1. Check the air cleaner body, cover, or filter for distortion, corrosion or damage.
2. Check the air duct for damage.

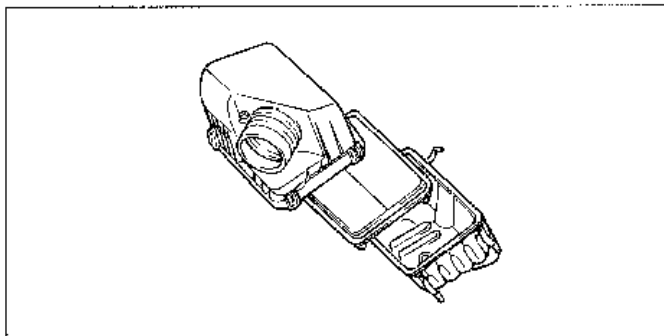

ECJA870A

3. Check the air cleaner element for restriction, contamination or damage. If the element is slightly restricted, remove the dust and debris by blowing compressed air from the inside of the element.

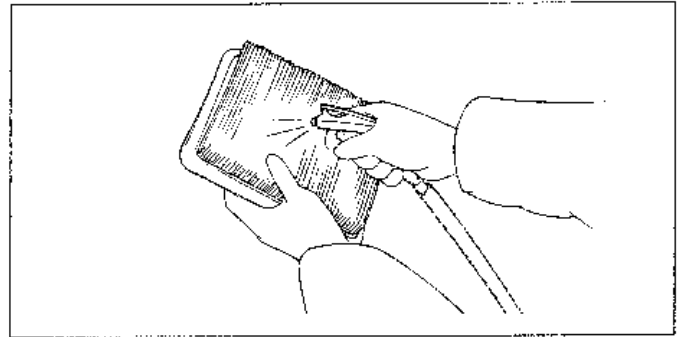

ECAP066A

INSTALLATION ECHA880D

Install the air cleaner assembly following the reverse order of removal.

CYLINDER HEAD ASSEMBLY

CYLINDER HEAD

COMPONENTS ECHB8950

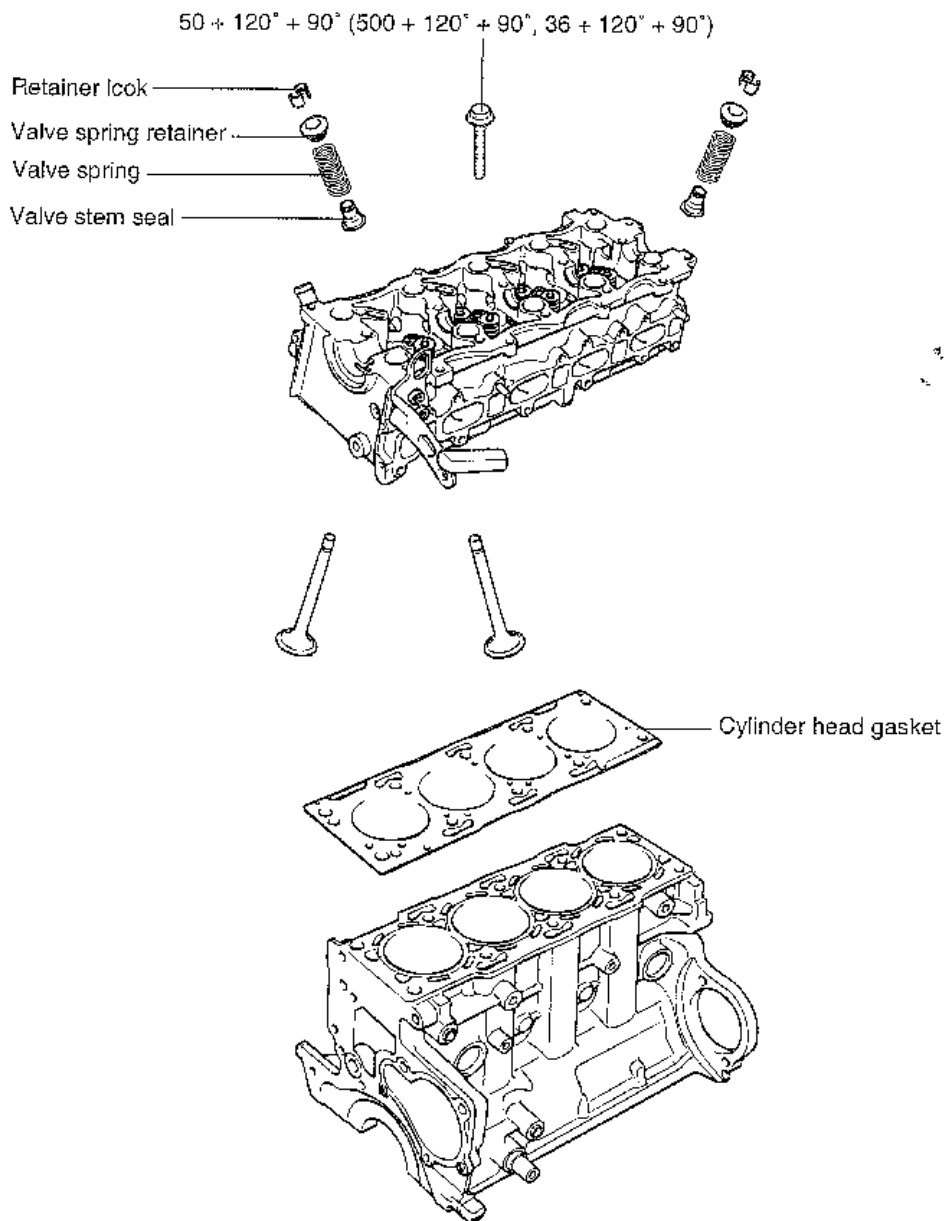

TORQUE : Nm (kg.cm, lb-ft)

DISASSEMBLY ECHB8960

1. Remove the cylinder head bolts in the order shown in the illustration.

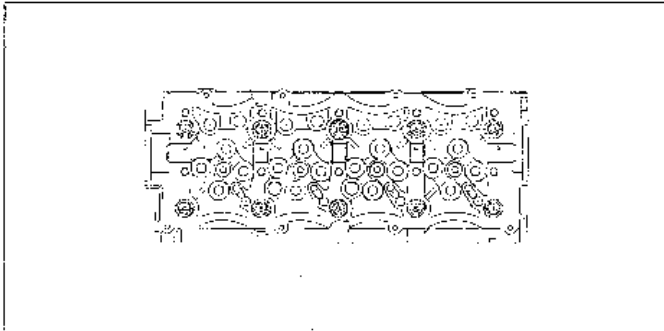

KCF-B012B

2. Using the special tool (09222 - 27300) remove the valve spring retainer lock. Then remove the spring retainer, valve spring, spring seat and valve.

NOTE

Arrange these parts so that they can be reinstalled in their original positions.

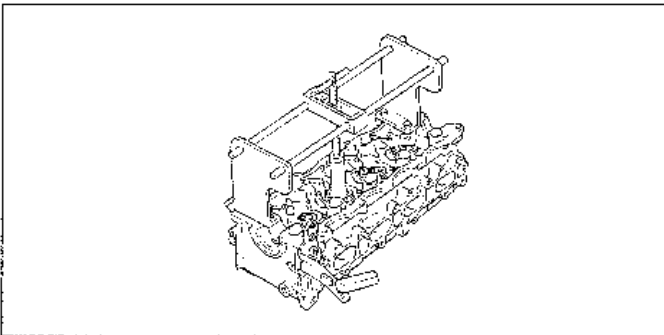

KCH6012F

3. Remove the valve stem seals with pliers.

NOTE

Do not reuse the valve stem seals.

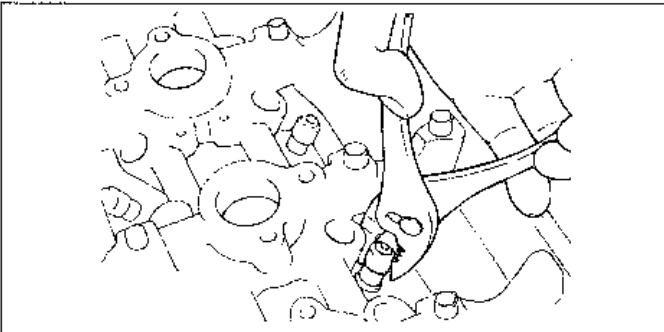

EGAB270C

INSPECTION ECHB8970

CYLINDER HEAD

1. Check the cylinder head for cracks, damage and coolant leakage. If cracked, replace the cylinder head.
2. Remove scale, sealing compound and carbon deposits completely. After cleaning the oil passages, apply compressed air to verify that the passages are not clogged.

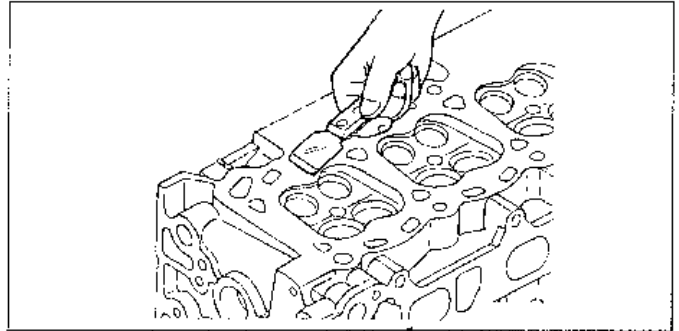

ECAB280A

3. Check the cylinder head surface for flatness in the direction as shown in the illustration. If flatness exceeds service limit in any direction, either replace the cylinder head or machine the cylinder head matching surface lightly.

Flatness of cylinder head gasket surface

Standard : Less than 0.03mm(0.0012 in.)

Limit : 0.2 mm (0.008 in.)

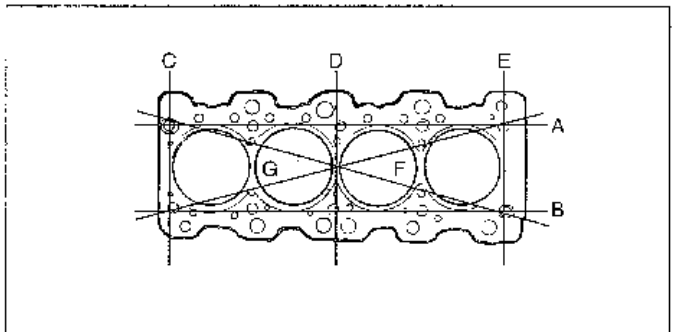

EC-1A920A

VALVES

1. Using a wire brush, clean the valve thoroughly.

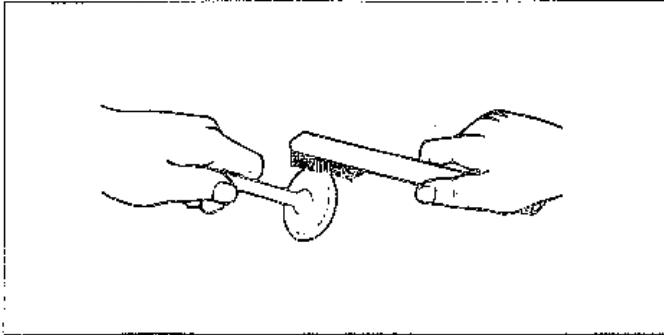

ECA9281A

2. Check each valve for wear, damage and distortion of the head and the stem at B Position. Replace, if necessary. If stem end, A, is hollowed out or worn, resurface as necessary. This correction must be limited to a minimum. Also resurface the valve face. Replace the valve if the margin has decreased to less than the service limit.

Margin

[Standard]

Intake : 1.6 mm (0.063 in.)

Exhaust : 1.3 mm (0.0512 in.)

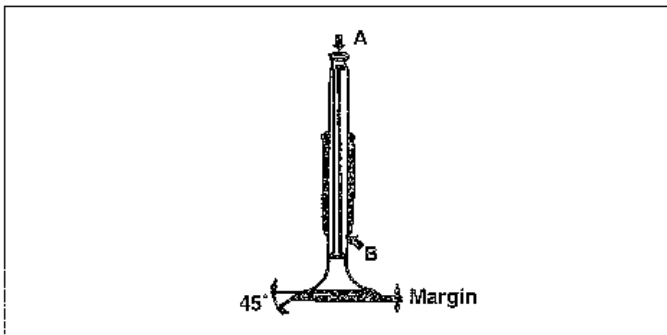

ECA9281B

VALVE SPRINGS

1. Check the free height of each valve spring. If they exceed the service limit, replace the springs.
2. Using a square, test the squareness of each spring. If a spring is excessively out-of-square, replace it.

Valve spring

[Standard]

Free height : 38.7 mm(1.52 in.)

Load : 21.4 kg / 32 mm (47.2 lb / 1.26 in.)

Out of square : 1.5° or less

[Limit]

Free height : 37.7 mm (1.48 in.)

Out of square : 4°

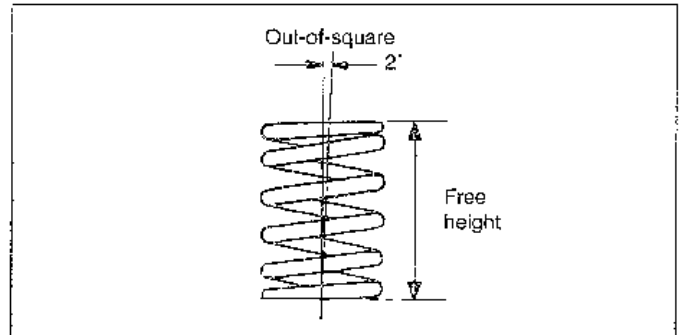

ECA9281C

VALVE GUIDES

Check the valve stem-to-guide clearance. If the clearance exceeds the service limit, replace the valve guide with the next oversize part.

Valve stem-to-guide clearance

[Standard]

Intake : 0.020 - 0.049 mm (0.0008 - 0.0020 in.)

Exhaust : 0.050 - 0.077 mm (0.0020 - 0.0033 in.)

[Limit]

Intake : 0.1 mm (0.0040 in)

Exhaust : 0.15 mm (0.0059 in.)

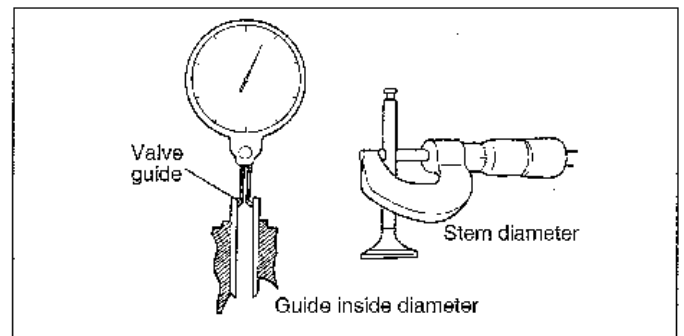

ECA9281D

RECONDITIONING VALVE SEAT

Check the valve seat for overheating and unequal contact with the valve face. Recondition or replace the seat if necessary. Before reconditioning the seat, check the valve guide for wear. If the valve guide is worn, replace it and then recondition the seat. Recondition the valve seat with a valve seat grinder or cutter. The valve seat contact width should be within specifications and centered on the valve face. After reconditioning, the valve and valve seat should be lapped lightly with a lapping compound.

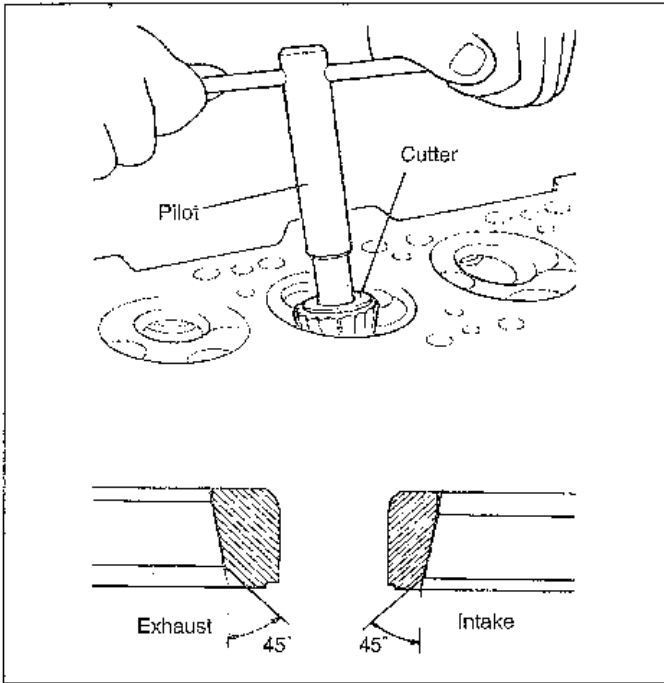

ECHA920B

REPLACING THE VALVE SEAT RING

1. Cut away the inner face of the valve seat to reduce the wall thickness.

VALVE SEAT INSERT OVSIZES

Description	Size mm (in.)	Size mark	Oversize hole diameter I.D. mm (in.)
Intake valve	0.3 (0.012) O.S.	30	29.993 - 30.006 (1.18 - 1.1813)
Seat ring	0.6 (0.024) O.S.	60	30.023 - 30.036 (1.182 - 1.1825)
Exhaust valve	0.3 (0.012) O.S.	30	25.393 - 25.406 (0.9997 - 1.0002)
Seat ring	0.6 (0.024) O.S.	60	25.423 - 25.436 (1.0009 - 1.0014)

REPLACING VALVE GUIDE

1. Using the special tool (09222 - 27000), withdraw the old valve guide toward the bottom of cylinder head.
2. Recondition the valve guide hole so that it can match the newly press-fitted oversize valve guide.

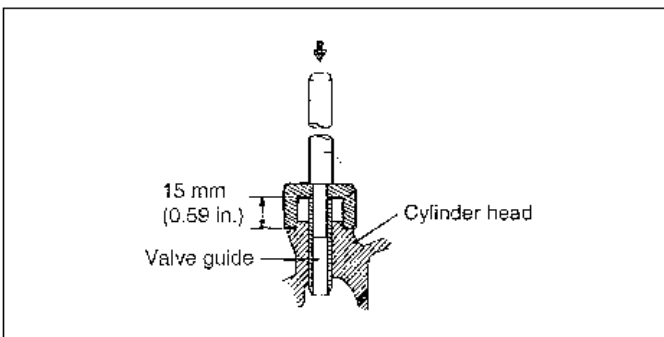

ECHB013Z

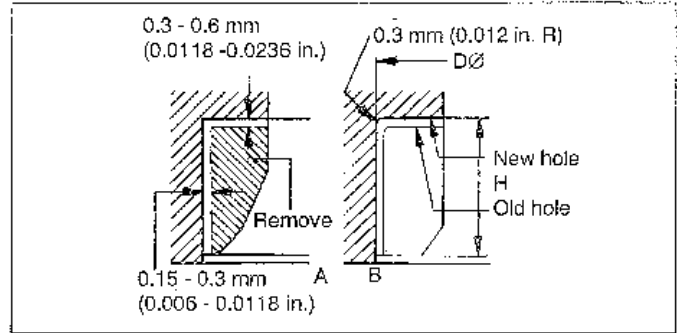

ECA9281F

2. Enlarge the diameter of the valve seat so that it matches the specified oversize hole diameter of the new valve seat ring.
3. Heat the cylinder head to about 250°C (480°F) and press-fit an oversize seat ring for the bore in the cylinder head.
4. Using lapping compound, lap the valve to the new seat.

Valve seat contact width :

IN : 1.21 mm (0.0477 in.)

EX : 1.61 mm (0.0634 in.)

3. Using the special tool (09222-21200 A, B), press-fit the valve guide. The valve guide must be press-fitted from the upper side of the cylinder head. Keep in mind that the intake and exhaust valve guides are different in length.

NOTE

Do not install a valve guide unless it is oversize.

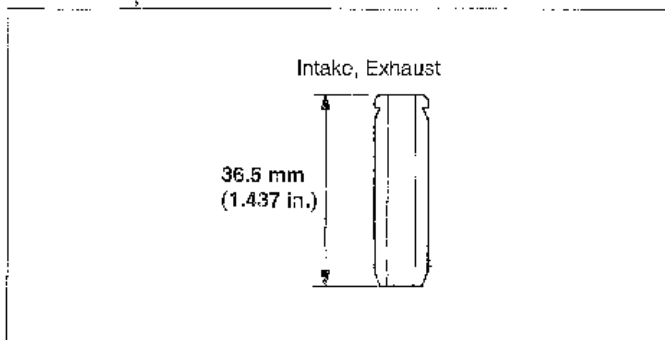

ECH-B012E

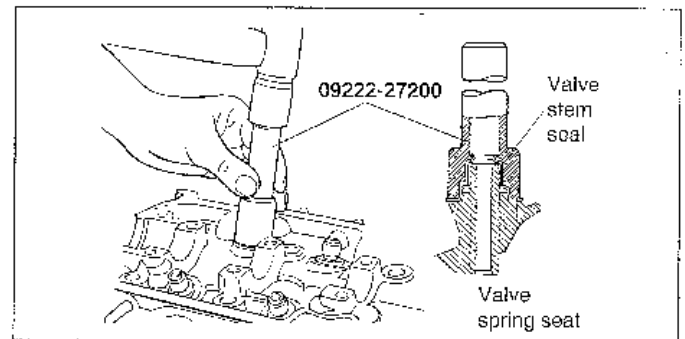

ECHE0127

4. After the valve guide is press-fitted, insert a new valve and check for proper stem-to-guide clearance.
5. After the valve guide is replaced, check that the valve is seated properly. Recondition the valve seats as necessary.

VALVE GUIDE OVERSIZES

Over size mm (in.)	Size mark	Oversize valve guide hole size mm (in.)
0.05(0.002)	5	12.805 - 13.205 (0.504 - 0.519)
0.25 (0.010)	25	12.825-13.225 (0.5049 - 0.5206)
0.50 (0.020)	50	12.85 - 13.25 (0.5059 - 0.5216)

REASSEMBLY ECH-B8980

NOTE

1. Clean each part before assembly.
2. Apply engine oil to the sliding and rotating parts.

1. Install the spring seats.
2. Using a special tool (09222 - 27200), tap the seal in position lightly.

NOTE

- Do not reuse old valve stem seals.
- Incorrect installation of the seal could result in oil leakage past the valve guides.

3. Apply engine oil to each valve. Insert the valve into the valve guide. Avoid pushing the valve into the seal by force. After inserting the valve, check that it moves smoothly.

4. Place valve springs so that the side coated with enamel faces the valve spring retainer and then install the retainer.

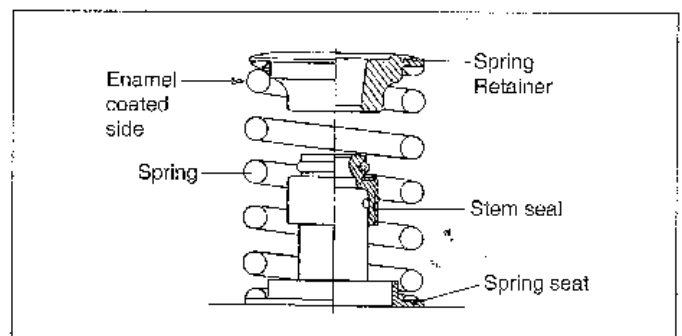

ECA8290B

5. Using the special tool (09222 - 27300), compress the spring and install the retainer locks. After installing the valves, ensure that the retainer locks are correctly in place before releasing the valve spring compressor.

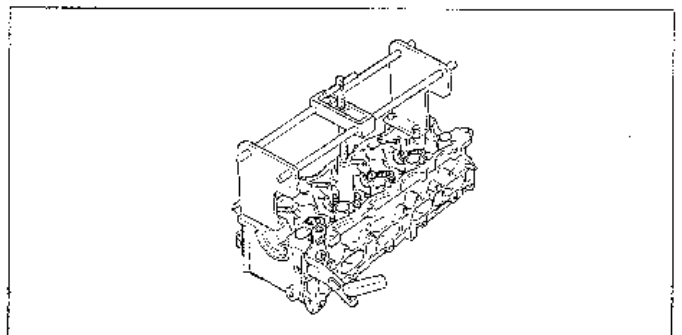

KCH9012F

NOTE

When the spring is compressed, Check that the valve stem seal is not pressed against the bottom of the retainer.

6. Clean both gasket surfaces of the cylinder block and cylinder head.
7. Verify the identification marks on the cylinder head gasket.

8. Install the gasket so that the surface with the identification mark faces toward the cylinder head.
9. Tighten the bolts to the specified torque.

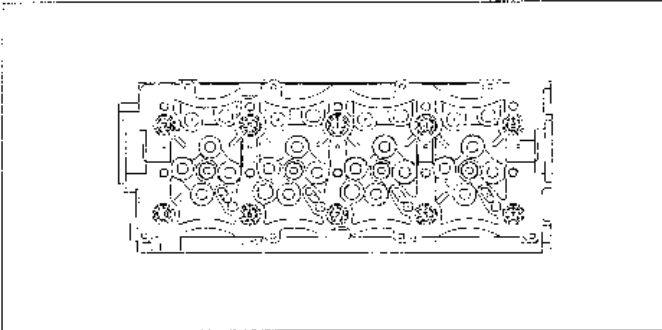

KCHB012C

Tightening torque

15 mm : 5 Nm (250 kg.cm, 18 lb.ft) + 120° + 90°

12 mm : 33 - 37 Nm (330 - 370 kg.cm, 24
- 27 lb.ft) + 120° + 90°

ROCKER COVER & PLUG

COMPONENTS ECHB9500

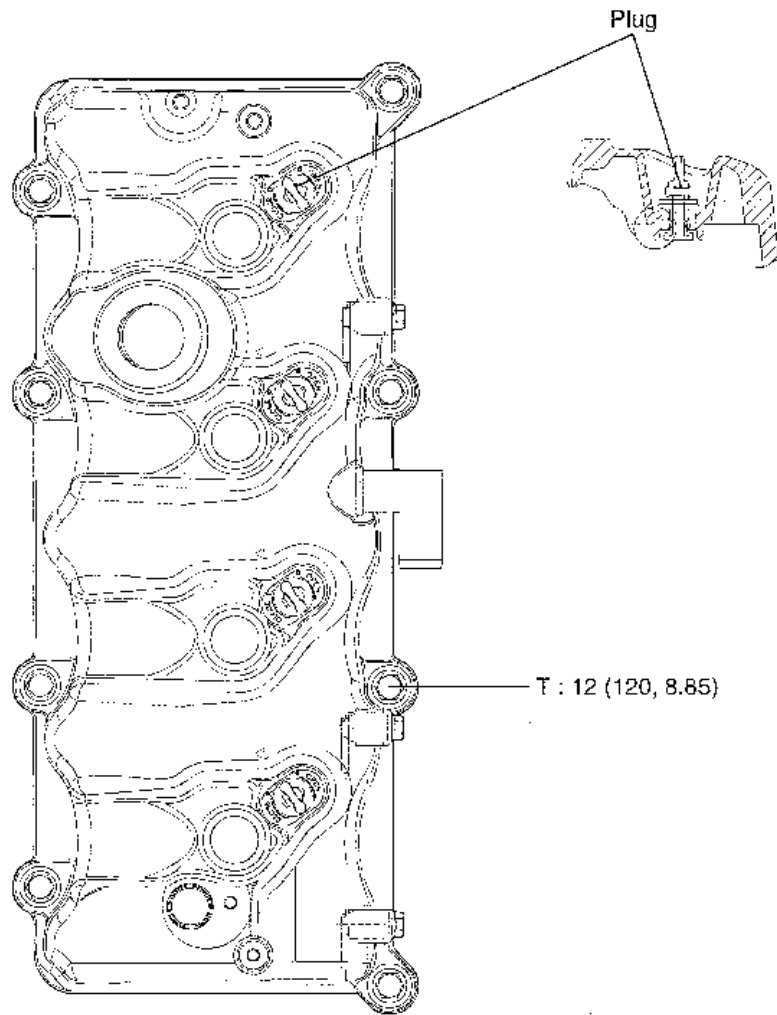

TORQUE : Nm (kg.cm, lb·ft)

REMOVAL ECHB9600

1. Remove the intercooler cover.

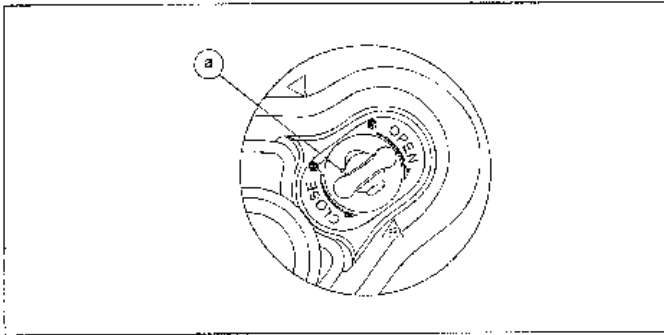

KCHB022B

INSTALLATION ECHB9700

1. Apply the oil to the plug.

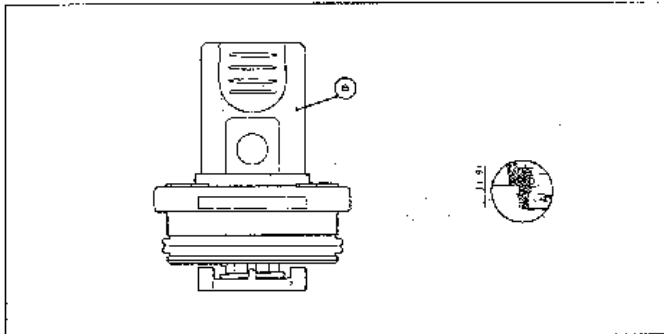

KCHB022C

2. Push the plug assembly and then turn the left.

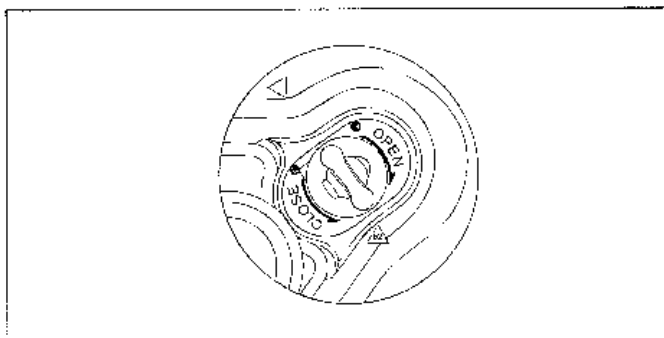

KCHB022D

NOTE

Whenever installing the plug, always replace a new one.

3. Using a special tool (09351 - 27400), install the injector oil seal.

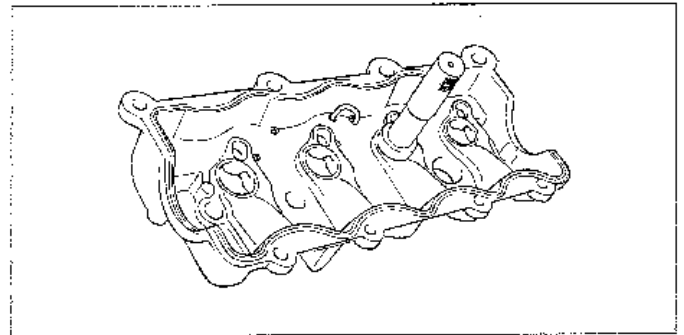

KCHB022E

4. Tighten the rocker cover bolts to the specified torque.

Tightening torque

1st step : 4Nm (40kg-cm, 2.95 lb.ft)

2nd step : 12Nm (120 kg-cm, 8.85 lb.ft)

TIMING SYSTEM

TIMING BELT

COMPONENTS ECHB9000

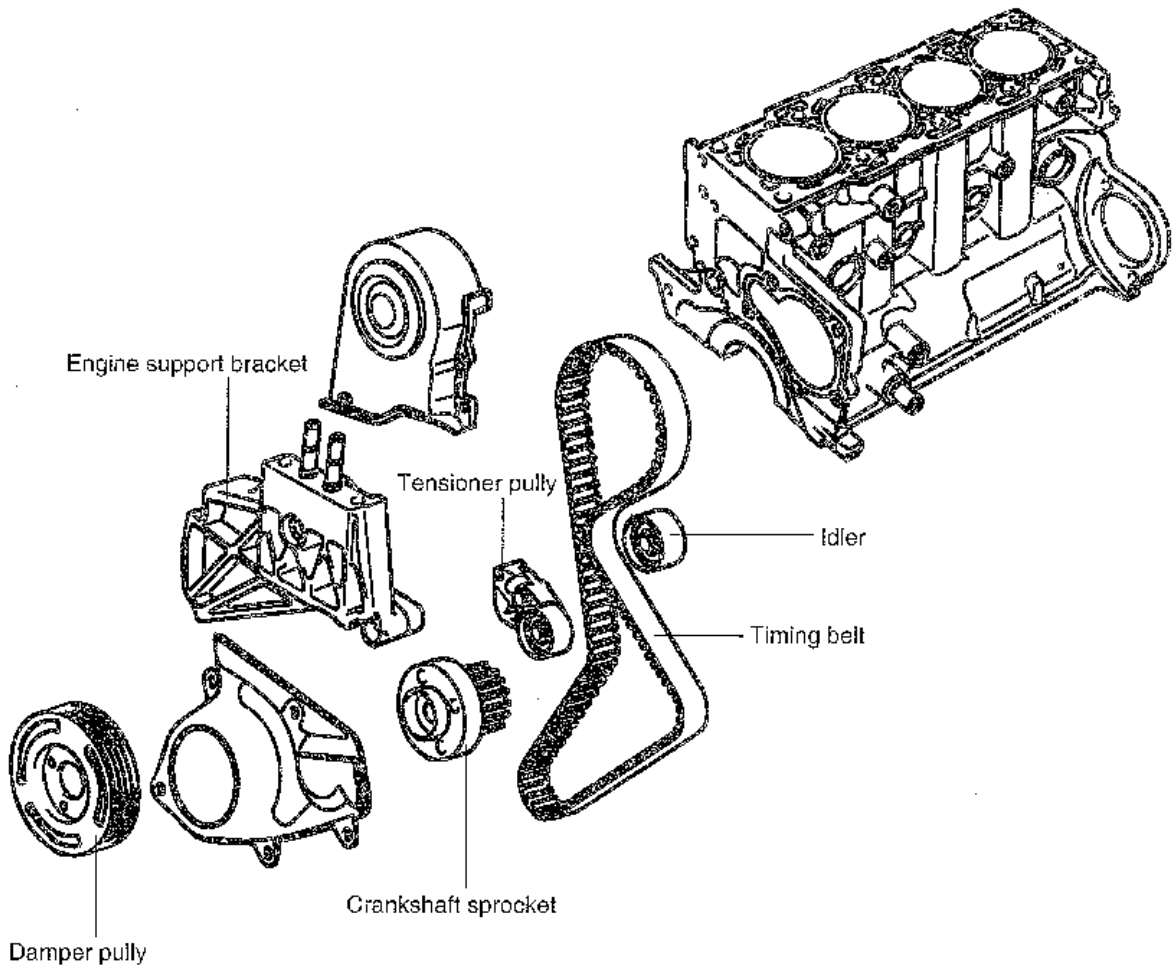

TORQUE : Nm (kg.cm, lb.ft)

REMOVAL ECH-B9100**CAUTION**

Rotate the crankshaft clockwise and align the timing marks to set the No. 1 cylinder's piston to TDC.

At this time, the timing marks of the camshaft sprocket and cylinder head cover should coincide with each other and the dowel pin of the camshaft sprocket should be at the upper side.

1. Remove the crankshaft pulley and drive belt.
2. Remove the timing belt cover.
3. Remove the auto tensioner.

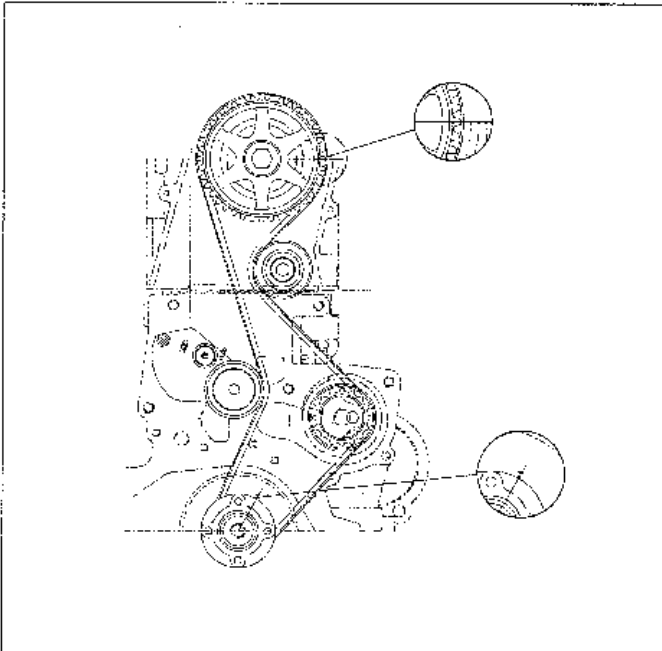

KCH-PC14B

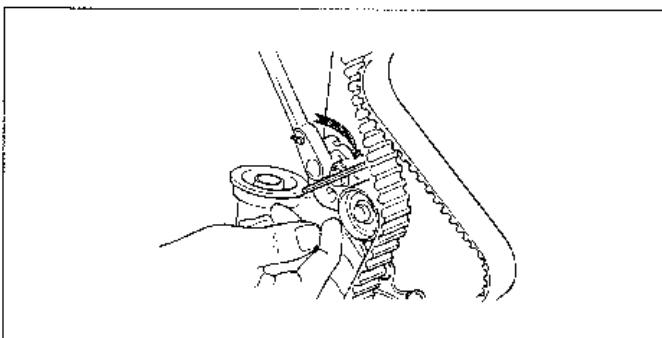

KCH-BC14C

NOTE

If the timing belt is reused, make an arrow mark indicating the turning direction (or the front of the engine) to make sure that the belt is reinstalled in the same direction as before.

4. Remove the timing belt.
5. Remove the camshaft sprockets.

INSPECTION ECH-B9200**SPROCKETS, TENSIONER PULLEY AND IDLER PULLEY**

1. Check the camshaft sprocket, crankshaft sprocket, tensioner pulley and idler pulley for abnormal wear, cracks or damage. Replace if necessary.
2. Inspect the tensioner pulley and the idler pulley for easy and smooth rotation and check for play or noise. Replace if necessary.
3. Replace the pulley if there is a grease leak from its bearing.

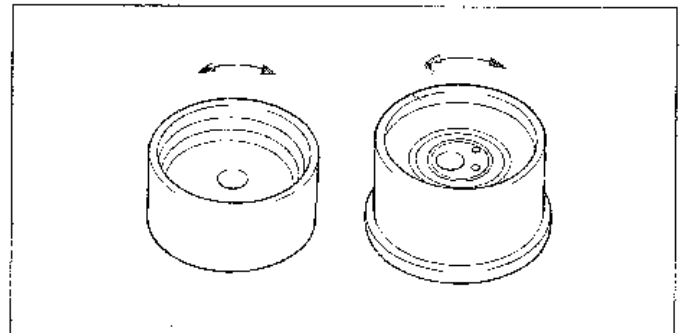

E0YD25A

AUTO TENSIONER

1. Check the auto tensioner for leaking and replace if necessary.
2. Check the rod end for wear or damage and replace if necessary.

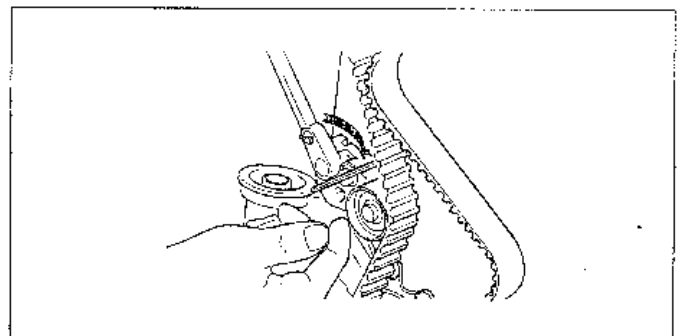

KCH-D014C





TIMING BELT

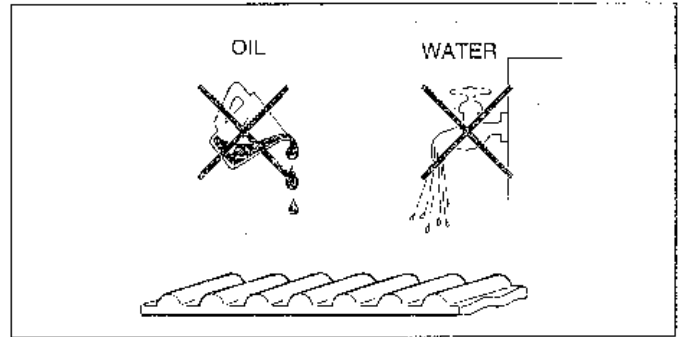

1. Check the belt for oil or dust deposit. Replace if necessary. Small deposits should be wiped away with a dry cloth or paper. Do not clean with solvent.

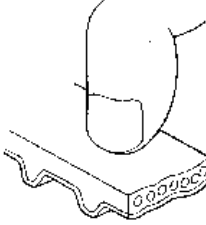
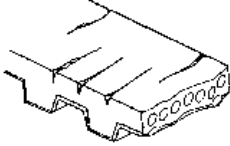
2. When the engine is overhauled or belt tension is adjusted, check the belt carefully. If any of the following flaws are evident, replace the belt with a new one.

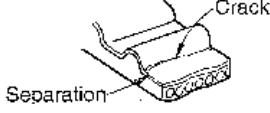

ECA9200A

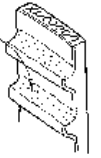
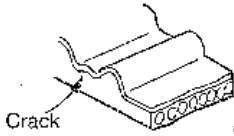
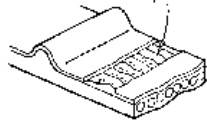
Description	Flaw conditions
<p>1. Hardened back surface of rubber</p>	<p>Back surface is glossy, Non-elastic and so hard that, when your fingernail is pressed into it, no mark is produced.</p>  <p style="text-align: right;">ECA92005</p>
<p>2. Cracked back surface of rubber</p>	 <p style="text-align: right;">ECA9200Y</p>
<p>3. Cracked or separating canvas</p>	 <p style="text-align: right;">ECA9200I</p>  <p style="text-align: right;">ECA9200J</p>  <p style="text-align: right;">ECA9200K</p>
<p>4. Badly worn out teeth (initial stage)</p>	<p>Tooth flank shows canvas on the load side (Fluffy canvas fibers, rubber changed into white color and unclear canvas texture)</p>

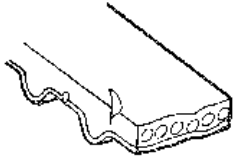
Description	Flaw conditions
5. Badly worn out teeth (last stage)	<p data-bbox="1050 286 1182 338">Flank worn (On load side)</p>  <p data-bbox="1453 443 1533 465">ECA9200C</p> <p data-bbox="818 483 1374 544">Tooth flank worn and rubber exposed on load side (tooth width reduced)</p>
6. Cracked tooth bottom	<p data-bbox="1075 591 1155 636">Rubber exposed</p>  <p data-bbox="1453 745 1533 768">ECA9200D</p>
7. Missing tooth	<p data-bbox="1054 898 1114 920">Crack</p>  <p data-bbox="1453 969 1533 992">ECA9200E</p>
8. Badly worn side of belt	<p data-bbox="1070 1016 1278 1061">Tooth missing and canvas fiber exposed</p>  <p data-bbox="1453 1211 1533 1234">ECA9200F</p>
9. Cracked side of belt	<p data-bbox="1086 1301 1262 1323">Rounded belt side</p>  <p data-bbox="1007 1451 1342 1473">Abnormal wear (Fluffy canvas fiber)</p> <p data-bbox="1453 1496 1533 1518">ECA9200G</p>
9. Cracked side of belt	 <p data-bbox="1453 1720 1533 1742">ECA9200H</p>

INSTALLATION ECHB9400

1. Install the crankshaft sprocket onto the crankshaft.

 **CAUTION**

Pay attention to the direction of the flange. If it is installed in the wrong direction, a broken belt could result.

2. Install the special washer and sprocket bolt to the crankshaft and then tighten the sprocket bolt.

Tightening torque

Crankshaft sprocket bolt :

185 - 195 Nm (1850 - 1950 kg-cm, 136 - 144 lb.ft)

3. Install the auto tensioner.

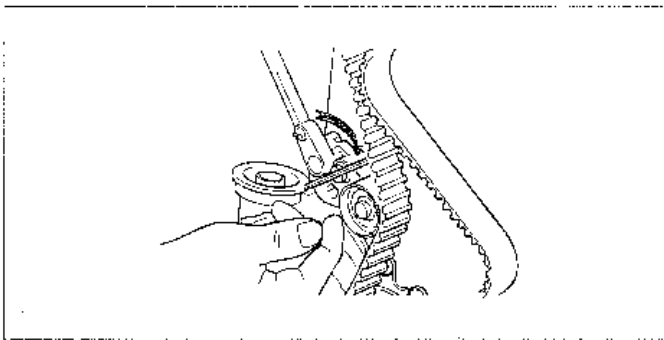

KCHB014C

TIMING BELT

1. Check timing mark.
 - Crankshaft side : Timing mark at crankshaft sprocket and timing pin at oil pump housing.
 - Camshaft side : Timing mark at camshaft sprocket and head.
2. Install tensioner.

3. Install timing belt.

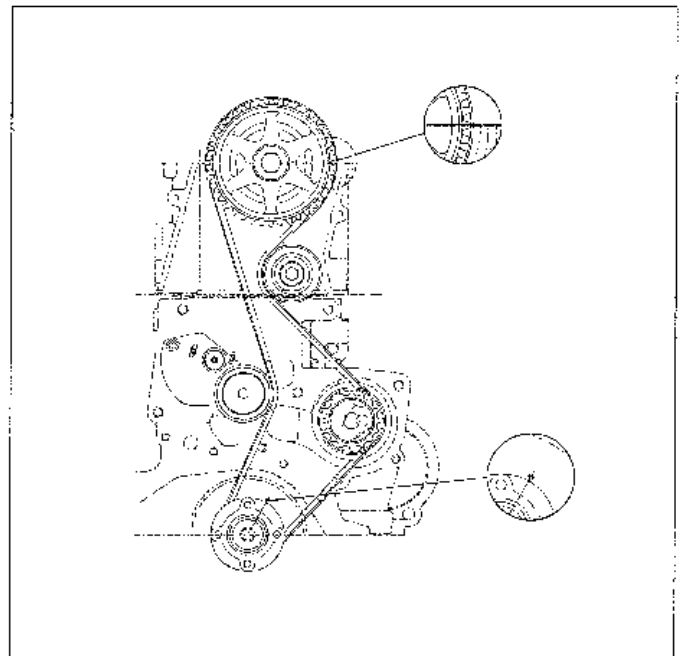

KCHB014B

4. Rotate engine more than 2 revolutions (Check timing mark).

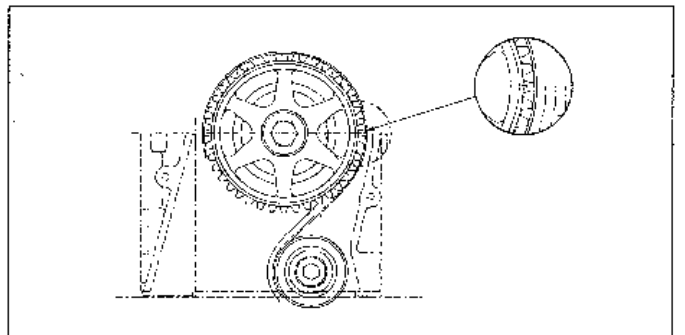

KCHB014E

5. Tighten stop bolt.